

Robots

KUKA Roboter GmbH

KR 1000 1300 titan PA, KR 1000 L950 titan PA

with F variants and KR C2

Specification

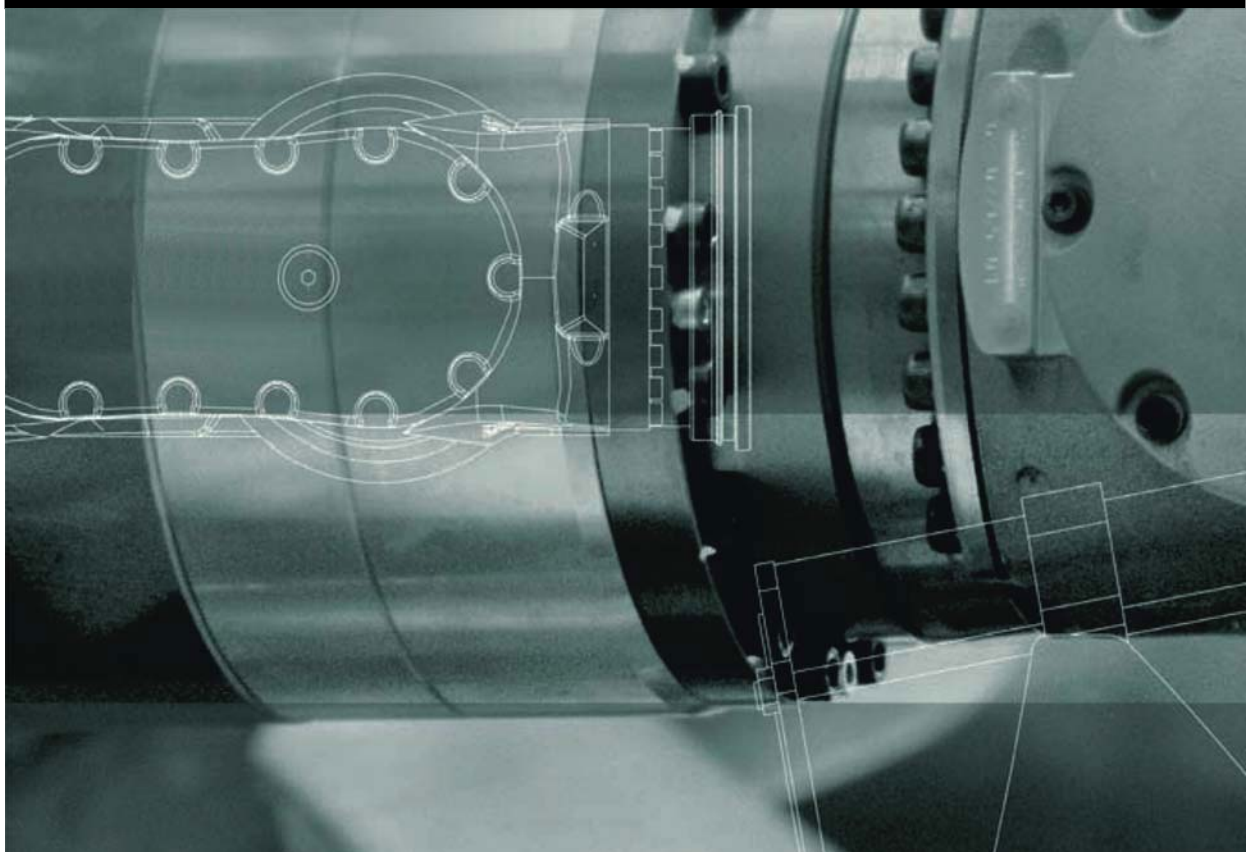

Issued: 20.06.2013

Version: Spez KR 1000 titan PA V4 en (PDF)



© Copyright 2013

KUKA Roboter GmbH
Zugspitzstraße 140
D-86165 Augsburg
Germany

This documentation or excerpts therefrom may not be reproduced or disclosed to third parties without the express permission of KUKA Roboter GmbH.

Other functions not described in this documentation may be operable in the controller. The user has no claims to these functions, however, in the case of a replacement or service work.

We have checked the content of this documentation for conformity with the hardware and software described. Nevertheless, discrepancies cannot be precluded, for which reason we are not able to guarantee total conformity. The information in this documentation is checked on a regular basis, however, and necessary corrections will be incorporated in the subsequent edition.

Subject to technical alterations without an effect on the function.

Translation of the original documentation

KIM-PS5-DOC

Publication:	Pub Spez KR 1000 titan PA en
Book structure:	Spez KR 1000 titan PA V4.1
Version:	Spez KR 1000 titan PA V4 en (PDF)

Contents

1	Introduction	5
1.1	Industrial robot documentation	5
1.2	Representation of warnings and notes	5
2	Purpose	7
2.1	Target group	7
2.2	Intended use	7
3	Product description	9
3.1	Overview of the industrial robot	9
3.2	Description of the robot	9
4	Technical data	13
4.1	Basic data, KR 1000 1300 titan PA	13
4.2	Basic data, KR 1000 L950 titan PA	15
4.3	Axis data	17
4.4	Payloads, KR 1000 1300 titan PA	20
4.5	Payloads, KR 1000 L950 titan PA	22
4.6	Foundation data	25
4.7	Plates and labels	26
4.8	Stopping distances and times	27
4.8.1	General information	27
4.8.2	Terms used	28
4.8.3	Stopping distances and times, KR 1000 1300 titan PA	29
4.8.3.1	Stopping distances and stopping times for STOP 0, axis 1 to axis 3	29
4.8.3.2	Stopping distances and stopping times for STOP 1, axis 1	30
4.8.3.3	Stopping distances and stopping times for STOP 1, axis 2	32
4.8.3.4	Stopping distances and stopping times for STOP 1, axis 3	34
4.8.4	Stopping distances and times, KR 1000 L950 titan PA	34
4.8.4.1	Stopping distances and stopping times for STOP 0, axis 1 to axis 3	34
4.8.4.2	Stopping distances and stopping times for STOP 1, axis 1	35
4.8.4.3	Stopping distances and stopping times for STOP 1, axis 2	37
4.8.4.4	Stopping distances and stopping times for STOP 1, axis 3	39
5	Safety	41
5.1	General	41
5.1.1	Liability	41
5.1.2	Intended use of the industrial robot	42
5.1.3	EC declaration of conformity and declaration of incorporation	42
5.1.4	Terms used	43
5.2	Personnel	44
5.3	Workspace, safety zone and danger zone	45
5.4	Overview of protective equipment	46
5.4.1	Mechanical end stops	46
5.4.2	Mechanical axis range limitation (optional)	46
5.4.3	Axis range monitoring (optional)	47
5.4.4	Options for moving the manipulator without drive energy	47
5.4.5	Labeling on the industrial robot	48

5.5	Safety measures	48
5.5.1	General safety measures	48
5.5.2	Transportation	49
5.5.3	Start-up and recommissioning	50
5.5.4	Manual mode	51
5.5.5	Automatic mode	51
5.5.6	Maintenance and repair	52
5.5.7	Decommissioning, storage and disposal	53
5.6	Applied norms and regulations	53
6	Planning	55
6.1	Mounting base with centering	55
6.2	Machine frame mounting	57
6.3	Connecting cables and interfaces	58
7	Transportation	61
7.1	Transporting the robot	61
8	KUKA Service	67
8.1	Requesting support	67
8.2	KUKA Customer Support	67
	Index	75

1 Introduction

1.1 Industrial robot documentation

The industrial robot documentation consists of the following parts:

- Documentation for the manipulator
- Documentation for the robot controller
- Operating and programming instructions for the KUKA System Software
- Documentation relating to options and accessories
- Parts catalog on storage medium

Each of these sets of instructions is a separate document.

1.2 Representation of warnings and notes

Safety

These warnings are relevant to safety and **must** be observed.

 DANGER	These warnings mean that it is certain or highly probable that death or severe injuries will occur, if no precautions are taken.
---	---

 WARNING	These warnings mean that death or severe injuries may occur, if no precautions are taken.
--	--

 CAUTION	These warnings mean that minor injuries may occur, if no precautions are taken.
--	--

NOTICE	These warnings mean that damage to property may occur, if no precautions are taken.
---------------	--

	These warnings contain references to safety-relevant information or general safety measures. These warnings do not refer to individual hazards or individual precautionary measures.
---	---

This warning draws attention to procedures which serve to prevent or remedy emergencies or malfunctions:

SAFETY INSTRUCTIONS	Procedures marked with this warning must be followed exactly.
----------------------------	--

Notes

These hints serve to make your work easier or contain references to further information.

	Tip to make your work easier or reference to further information.
---	---

2 Purpose

2.1 Target group

This documentation is aimed at users with the following knowledge and skills:

- Advanced knowledge of mechanical engineering
- Advanced knowledge of electrical and electronic systems
- Knowledge of the robot controller system



For optimal use of our products, we recommend that our customers take part in a course of training at KUKA College. Information about the training program can be found at www.kuka.com or can be obtained directly from our subsidiaries.

2.2 Intended use

Use The industrial robot is intended for handling tools and fixtures, or for processing or transferring components or products. Use is only permitted under the specified environmental conditions.

Misuse Any use or application deviating from the intended use is deemed to be impermissible misuse. This includes e.g.:

- Transportation of persons and animals
- Use as a climbing aid
- Operation outside the permissible operating parameters
- Use in potentially explosive environments
- Use in underground mining

NOTICE

Changing the structure of the manipulator, e.g. by drilling holes, etc., can result in damage to the components. This is considered improper use and leads to loss of guarantee and liability entitlements.



The robot system is an integral part of a complete system and may only be operated in a CE-compliant system.

3 Product description

3.1 Overview of the industrial robot

The industrial robot consists of the following components:

- Manipulator
- Robot controller
- Teach pendant
- Connecting cables
- Software
- Options, accessories

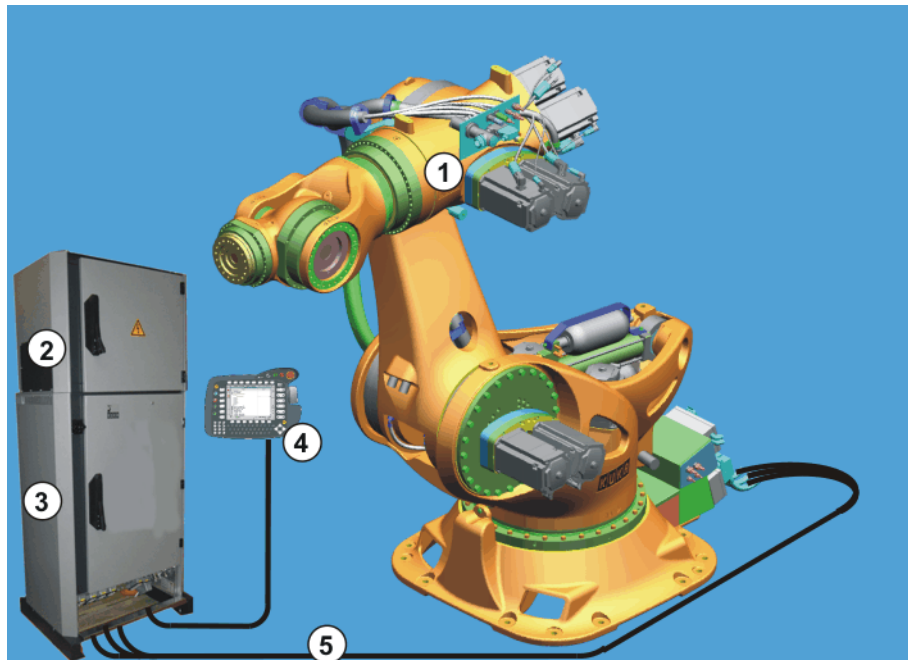

Fig. 3-1: Example of an industrial robot

- | | | | |
|---|---------------------|---|---------------------|
| 1 | Manipulator | 4 | Teach pendant (KCP) |
| 2 | Top-mounted cabinet | 5 | Connecting cables |
| 3 | Robot controller | | |

3.2 Description of the robot

Overview

The robots are designed as 6-axis jointed-arm kinematic systems. The structural components of the robot are made of iron castings. The design and structure of the robot variants KR 1000 titan and KR 1000 titan PA are identical. The robot may only be operated in palletizing mode with the specified rated payloads.

The robot consists of the following principal components:

- In-line wrist
- Arm
- Link arm
- Rotating column
- Base frame
- Counterbalancing system
- Electrical installations

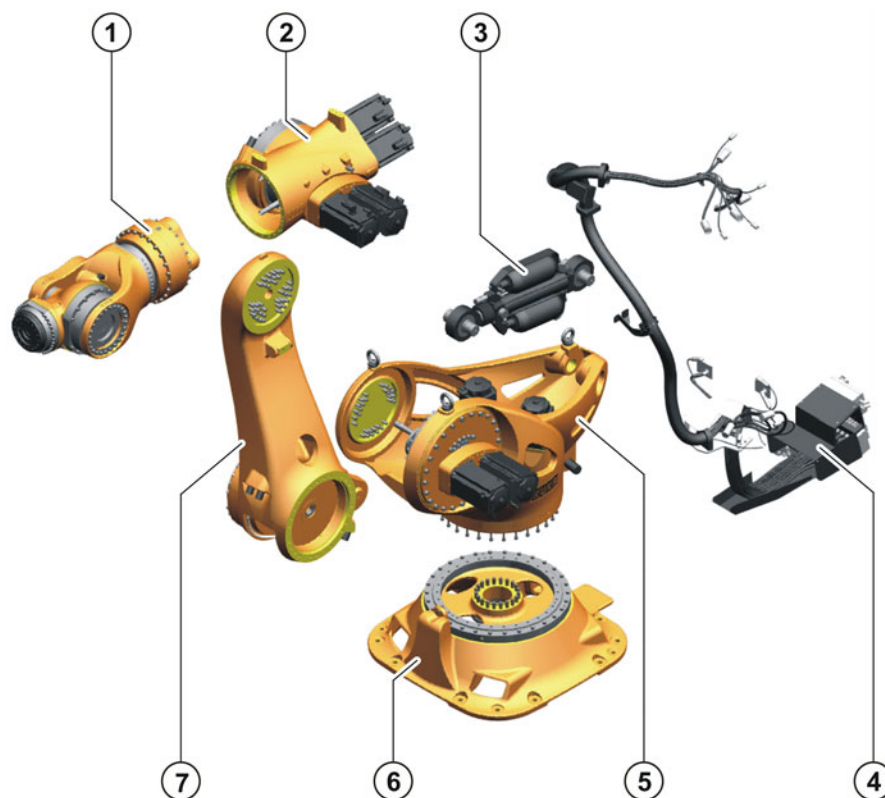

Fig. 3-2: Principal components of the KR 1000 titan

1	In-line wrist	5	Rotating column
2	Arm	6	Base frame
3	Counterbalancing system	7	Link arm
4	Electrical installations		

In-line wrist

The robot is fitted with a 3-axis in-line wrist. The in-line wrist comprises axes 4, 5 and 6. It is driven by 3 motors installed at the rear end of the arm via connecting shafts. For attaching end effectors (tools), the in-line wrist has a mounting flange. The gear units of the in-line wrist are supplied with oil from 3 separate oil chambers. The robot can be equipped with an in-line wrist for a rated payload of 1000 kg or 750 kg, depending on the variant. The 1000 kg in-line wrist is used in palletizing mode with a rated payload of 1300 kg. The 750 kg in-line wrist is 400 mm longer and can be operated with a rated payload of 950 kg.

If the robot is used in palletizing mode, axis 4 is deactivated and axis 5 is always kept parallel to the robot mounting plane, depending on the specific program.

Additional measures have been taken to enable in-line wrists of the F variants to meet higher specifications in terms of resistance to temperature, dust and corrosion. F variant in-line wrists meet the requirements of IP 67.

Arm

The arm is the link between the in-line wrist and the link arm. It houses the motors of the wrist axes A4, A5 and A6 and the motors of main axis A3. The arm is driven by the 2 motors of axis 3, which drive the gear unit between the arm and the link arm via an input stage. The maximum permissible swivel angle is mechanically limited by a stop for each direction, plus and minus. The associated buffers are attached to the arm.

The arms of the F variants are pressurized to prevent penetration of moisture and dust. The required compressed air is supplied via a hose in the cable har-

ness. The pressure regulator for this is installed in the push-in module for the electrical installations.

- Link arm** The link arm is the assembly located between the arm and the rotating column. It is mounted in the rotating column with a gear unit on each side and is driven by 2 motors. The two motors engage with an input stage before driving both gear units via a shaft.
- Rotating column** The rotating column houses the motors of axes 1 and 2. The rotational motion of axis 1 is performed by the rotating column. It is screwed to the base frame via the gear unit of axis 1. The motors for driving axis 1 are mounted inside the rotating column. The bearings of the counterbalancing system are situated at the rear.
- Base frame** The base frame is the base of the robot. It is screwed to the mounting base. The interfaces for the electrical installations and the energy supply systems (accessory) are housed in the base frame. For transportation by fork lift truck, fork slots are provided on the base frame.
- Counterbalancing system** The counterbalancing system is installed between the rotating column and the link arm and serves to minimize the moments generated about axis 2 when the robot is in motion and at rest. A closed, hydropneumatic system is used. The system consists of 2 diaphragm accumulators and a cylinder with associated hoses, pressure gauge and safety valve.
- When the link arm is vertical, the counterbalancing system has no effect. With increasing deflection in the plus or minus direction, the hydraulic oil is pressed into the two diaphragm accumulators, thereby generating the necessary counterforce to compensate the moment of the axis. The diaphragm accumulators are filled with nitrogen.
- Different variants of the counterbalancing system are used for F variant robots. These variants are characterized by their improved resistance to dust, temperature and humidity.

4 Technical data

4.1 Basic data, KR 1000 1300 titan PA

Basic data

Type	KR 1000 1300 titan PA
Number of axes	4
Volume of working envelope	69.5 m ³
Pose repeatability (ISO 9283)	±0.10 mm
Working envelope reference point	Intersection of the center of the mounting flange face with axis 6
Weight	approx. 4,690 kg
Principal dynamic loads	See "Loads acting on the mounting base"
Protection classification of the robot	IP 65 ready for operation, with connecting cables plugged in (according to EN 60529)
Protection classification of the in-line wrist	IP 65
Protection classification of the F in-line wrist	IP 67
Sound level	< 75 dB (A) outside the working envelope
Mounting position	Floor
Surface finish, paint-work	Base (stationary): black (RAL 9005); moving parts: KUKA orange 2567

Transport dimensions

	Without buffer A2	With buffer A2
Length	2,123 mm	2,106 mm
Width	1,420 mm	1,420 mm
Height	2,371 mm	2,543 mm
	These dimensions refer to the robot only, without wooden transport blocks.	

Transport dimensions with transport frame

Length	4,000 mm
Width	1,750 mm
Height	2,191 mm
Height with lifting tackle	3,500 mm

Foundry robots

Overpressure in the arm	0.01 MPa (0.1 bar)
Compressed air	Free of oil and water
Compressed air supply line	Air line in the cable set
Air consumption	0.1 m ³ /h
Air line connection	Quick Star push-in fitting for hose PUN-6x1, blue
Pressure regulator connection	R 1/8", internal thread
Input pressure	0.1 - 1.2 MPa (1 - 12 bar)

Pressure regulator	0.005 - 0.07 MPa (0.05 - 0.7 bar)
Manometer range	0.0 - 0.1 MPa (0.0 - 1.0 bar)
Filter gauge	25 - 30 µm
Thermal loading	10 s/min at 353 K (180 °C)
Resistance	Increased resistance to dust, lubricants, coolants and water vapor.
Special paint finish on wrist	Heat-resistant and heat-reflecting silver paint finish on the in-line wrist.
Special paint finish on the robot	Special paint finish on the entire robot, and an additional protective clear coat.
Other ambient conditions	KUKA Roboter GmbH must be consulted if the robot is to be used under other ambient conditions.

Ambient temperature

Operation	283 K to 328 K (+10 °C to +55 °C)
Operation with Safe RDC	283 K to 323 K (+10 °C to +50 °C)
Storage and transportation	233 K to 333 K (-40 °C to +60 °C)
Start-up	283 K to 288 K (+10 °C to +15 °C) At these temperatures the robot may have to be warmed up before normal operation. Other temperature limits available on request.
Humidity rating	DIN EN 60721-3-3, Class 3K3

The maintenance intervals and the specified service life are based on typical gear unit temperatures and axis motions. If special functions or applications result in atypical gear unit temperatures or axis motions, this can lead to increased wear. In this case, the maintenance intervals or service life may be shortened. If you have any questions, please contact KUKA Customer Support.

Connecting cables

Cable designation	Connector designation	Interface with robot
Motor cable 1	X20.1 - X30.1	Rectangular connector, size 24
Motor cable 2	X20.2 - X30.2	Rectangular connector, size 24
Motor cable 3	X20.3 - X30.3	Rectangular connector, size 24
Control cable 1, A1/A2	XA21 - X31.2	Circular connector M23
Control cable 2, A1/A2	X21.1 - X41	Circular connector M23
Safe control cable	X21 - X31	Circular connector M23
Ground conductor		Ring cable lug, 8 mm

Cable lengths	
Standard	15 m, 25 m, 35 m, 50 m
with RoboTeam	15 m, 25 m, 35 m
with SafeRobot	15 m, 25 m, 35 m

For detailed specifications of the connecting cables, see (>>> 6.3 "Connecting cables and interfaces" Page 58)

For connecting cables longer than 35 m an additional ground conductor is provided and must be installed.

4.2 Basic data, KR 1000 L950 titan PA

Basic data

Type	KR 1000 L950 titan PA
Number of axes	4
Volume of working envelope	102.5 m ³
Pose repeatability (ISO 9283)	±0.10 mm
Working envelope reference point	Intersection of the center of the mounting flange face with axis 6
Weight	approx. 4,740 kg
Principal dynamic loads	See "Loads acting on the mounting base"
Protection classification of the robot	IP 65 ready for operation, with connecting cables plugged in (according to EN 60529)
Protection classification of the in-line wrist	IP 65
Protection classification of the F in-line wrist	IP 67
Sound level	< 75 dB (A) outside the working envelope
Mounting position	Floor
Surface finish, paint-work	Base (stationary): black (RAL 9005); moving parts: KUKA orange 2567

Transport dimensions

	Without buffer A2	With buffer A2
Length	2,506 mm	2,506 mm
Width	1,420 mm	1,420 mm
Height	2,371 mm	2,543 mm
	These dimensions refer to the robot only, without wooden transport blocks.	

Transport dimensions with transport frame

Length	4,000 mm
Width	1,750 mm
Height	2,191 mm
Height with lifting tackle	3,500 mm

Foundry robots

Overpressure in the arm	0.01 MPa (0.1 bar)
Compressed air	Free of oil and water
Compressed air supply line	Air line in the cable set
Air consumption	0.1 m ³ /h

Air line connection	Quick Star push-in fitting for hose PUN-6x1, blue
Pressure regulator connection	R 1/8", internal thread
Input pressure	0.1 - 1.2 MPa (1 - 12 bar)
Pressure regulator	0.005 - 0.07 MPa (0.05 - 0.7 bar)
Manometer range	0.0 - 0.1 MPa (0.0 - 1.0 bar)
Filter gauge	25 - 30 µm
Thermal loading	10 s/min at 353 K (180 °C)
Resistance	Increased resistance to dust, lubricants, coolants and water vapor.
Special paint finish on wrist	Heat-resistant and heat-reflecting silver paint finish on the in-line wrist.
Special paint finish on the robot	Special paint finish on the entire robot, and an additional protective clear coat.
Other ambient conditions	KUKA Roboter GmbH must be consulted if the robot is to be used under other ambient conditions.

Ambient temperature

Operation	283 K to 328 K (+10 °C to +55 °C)
Operation with Safe RDC	283 K to 323 K (+10 °C to +50 °C)
Storage and transportation	233 K to 333 K (-40 °C to +60 °C)
Start-up	283 K to 288 K (+10 °C to +15 °C) At these temperatures the robot may have to be warmed up before normal operation. Other temperature limits available on request.
Humidity rating	DIN EN 60721-3-3, Class 3K3

The maintenance intervals and the specified service life are based on typical gear unit temperatures and axis motions. If special functions or applications result in atypical gear unit temperatures or axis motions, this can lead to increased wear. In this case, the maintenance intervals or service life may be shortened. If you have any questions, please contact KUKA Customer Support.

Connecting cables

Cable designation	Connector designation	Interface with robot
Motor cable 1	X20.1 - X30.1	Rectangular connector, size 24
Motor cable 2	X20.2 - X30.2	Rectangular connector, size 24
Motor cable 3	X20.3 - X30.3	Rectangular connector, size 24
Control cable 1, A1/A2	XA21 - X31.2	Circular connector M23
Control cable 2, A1/A2	X21.1 - X41	Circular connector M23
Safe control cable	X21 - X31	Circular connector M23
Ground conductor		Ring cable lug, 8 mm

Cable lengths	
Standard	15 m, 25 m, 35 m, 50 m

with RoboTeam	15 m, 25 m, 35 m
with SafeRobot	15 m, 25 m, 35 m

For detailed specifications of the connecting cables, see

For connecting cables longer than 35 m an additional ground conductor is provided and must be installed.

4.3 Axis data

The following data are valid for the robots KR 1000 1300 titan PA and KR 1000 L950 titan PA.

Axis data

Axis	Range of motion, software-limited	Speed with rated payload
1	+/-150°	58°/s
2	+17.5° to -130°	50°/s
3	+145° to -110°; in palletizing mode +62° to +145°	50°/s
5	+/-118° program-dependent, parallel to the robot mounting plane	60°/s
6	+/-350°	72°/s

The direction of motion and the arrangement of the individual axes may be noted from the diagram (>>> Fig. 4-1). Axis 5 is in palletizing mode.

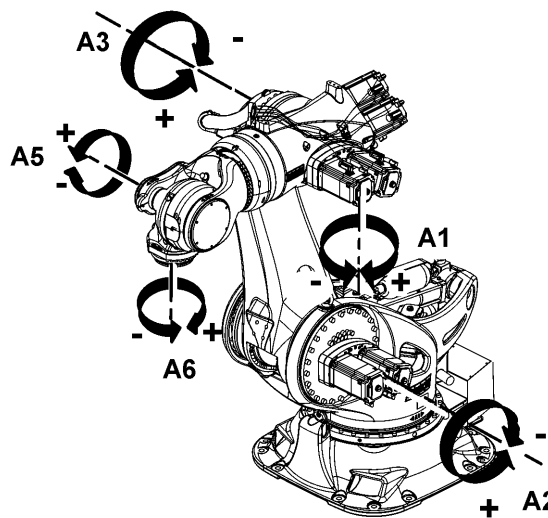

Fig. 4-1: Direction of rotation of robot axes

The diagrams (>>> Fig. 4-2) and (>>> Fig. 4-3) show the shape and size of the working envelopes.

Working envelope

Maße / Dimensions: mm

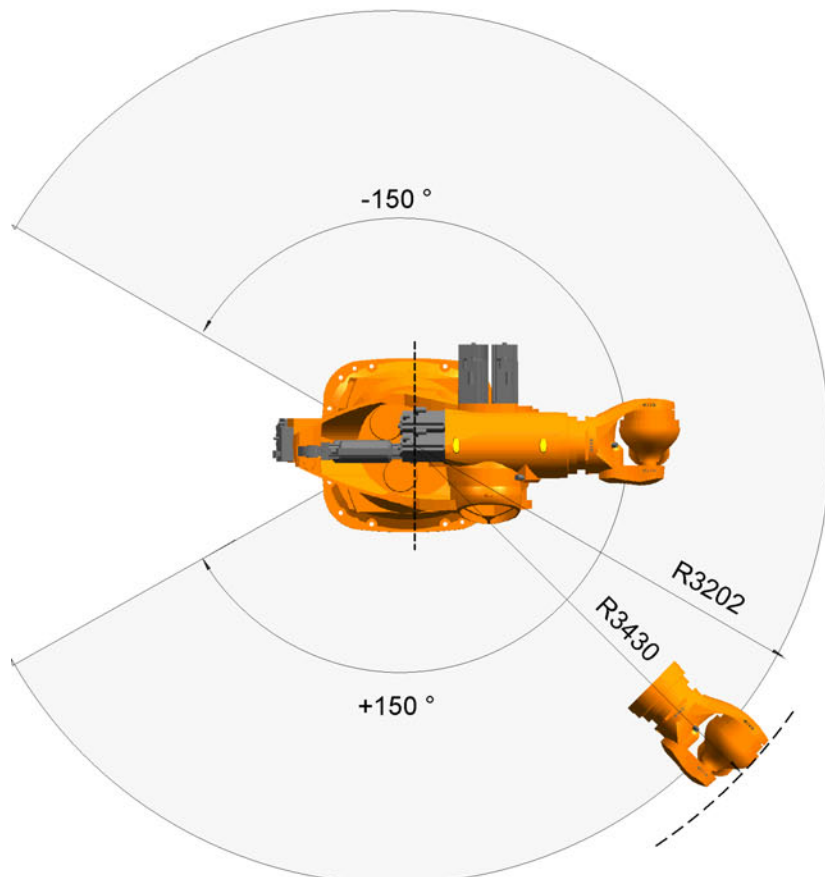
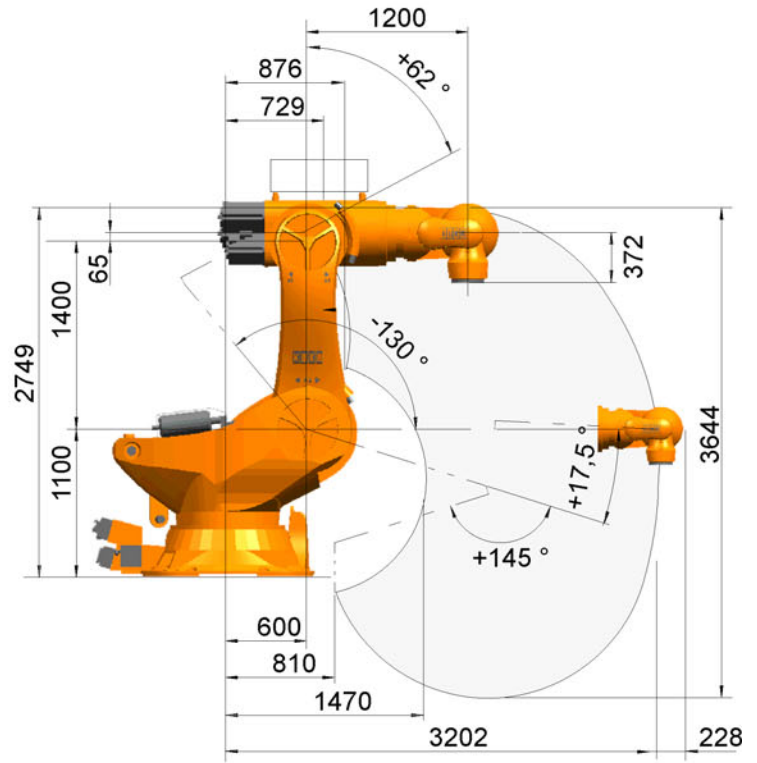

Fig. 4-2: Working envelope, KR 1000 1300 titan PA

Maße / Dimensions: mm

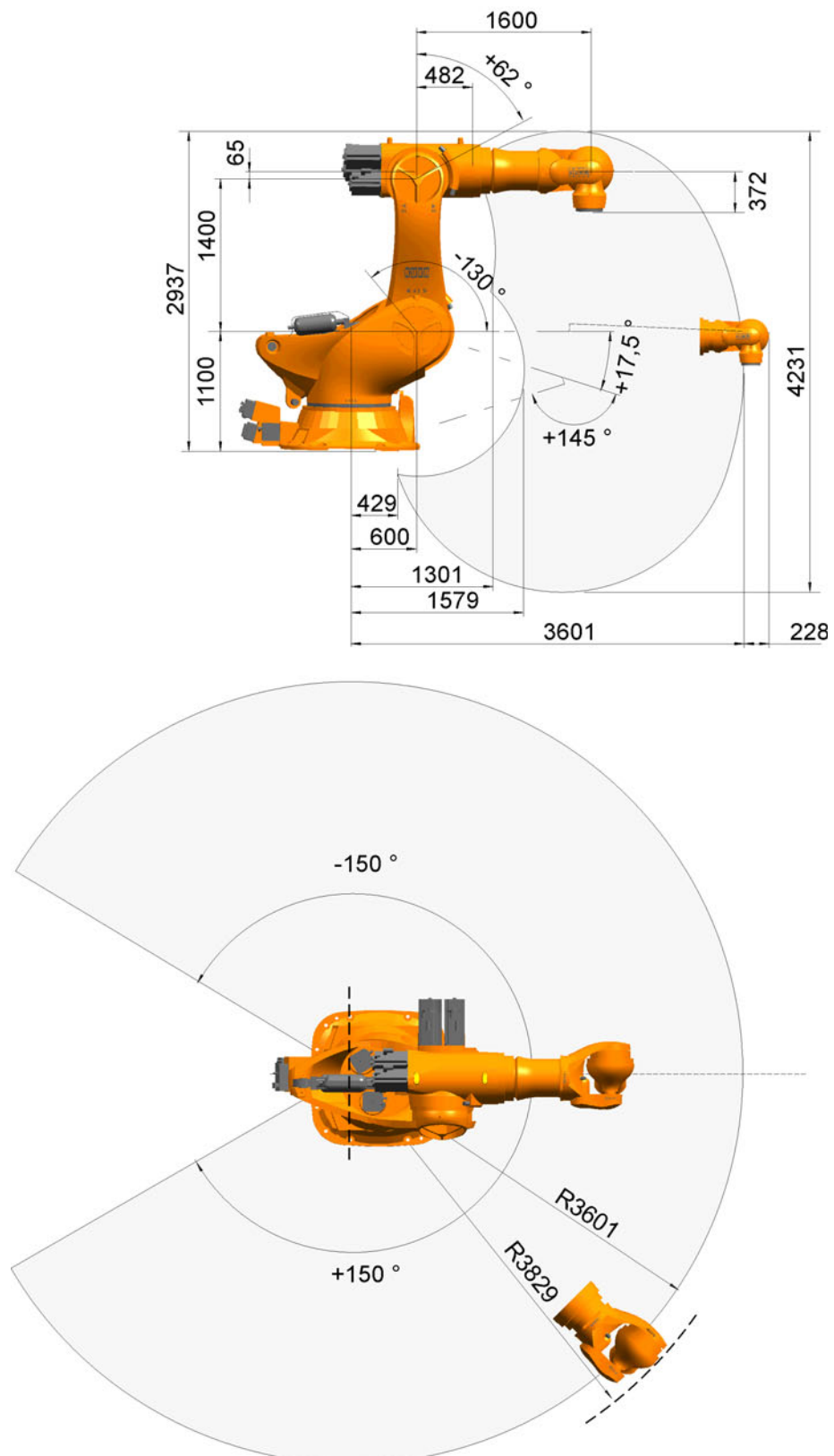

Fig. 4-3: Working envelope, KR 1000 L950 titan PA

The reference point for the working envelope is the intersection of the mounting flange face with axis 6.

4.4 Payloads, KR 1000 1300 titan PA

Payloads

Robot	KR 1000 1300 titan PA
In-line wrist	IW 1000
Rated payload	1,300 kg
Distance of the load center of gravity L_z	400 mm
Distance of the load center of gravity L_{xy}	150 mm
Permissible moment of inertia	500 kgm ²
Max. total load = Payload + Supplementary load	1,350 kg
Supplementary load, arm	100 kg
Supplementary load, link arm	0 kg
Supplementary load, rotating column	0 kg
Supplementary load, base frame	0 kg

Load center of gravity P

For all payloads, the load center of gravity refers to the distance from the face of the mounting flange on axis 6. Refer to the payload diagram for the nominal distance.

Payload diagram

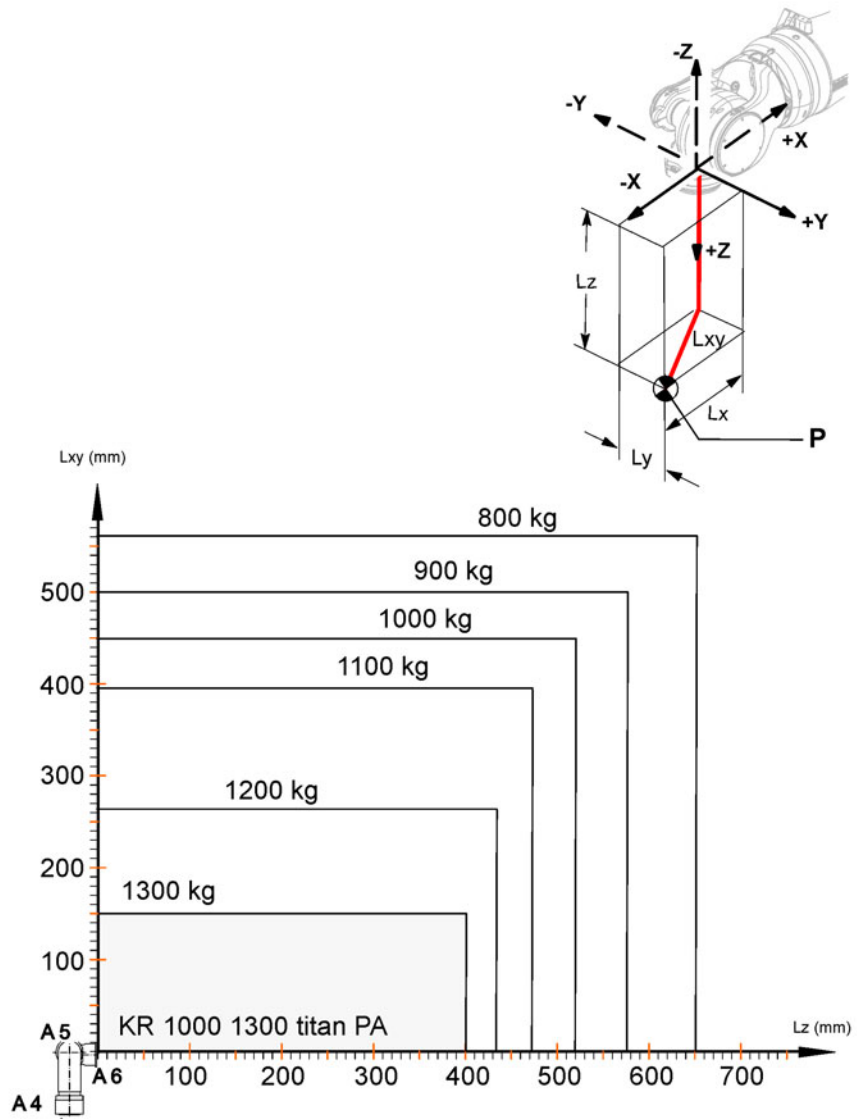

Fig. 4-4: Payload diagram for KR 1000 1300 titan PA

NOTICE

This loading curve corresponds to the maximum load capacity. Both values (payload and mass moment of inertia) must be checked in all cases. Exceeding this capacity will reduce the service life of the robot and overload the motors and the gears; in any such case the KUKA Roboter GmbH must be consulted beforehand.

The values determined here are necessary for planning the robot application. For commissioning the robot, additional input data are required in accordance with operating and programming instructions of the KUKA System Software.

The mass inertia must be verified using KUKA.Load. It is imperative for the load data to be entered in the robot controller!

Mounting flange

Mounting flange	similar to DIN/ISO 9409-1-A200*
Screw grade	10.9
Screw size	M16
Grip length	1.5 x nominal diameter
Depth of engagement	min. 24 mm, max. 25 mm
Locating element	12 ^{H7}

*The inner locating diameter is $\varnothing 160$ ^{H7}. This deviates from the standard.

The mounting flange is depicted (>>> "Mounting flange" Page 21) with axes 4 and 6 in the zero position. The symbol X_m indicates the position of the locating element (bushing) in the zero position.

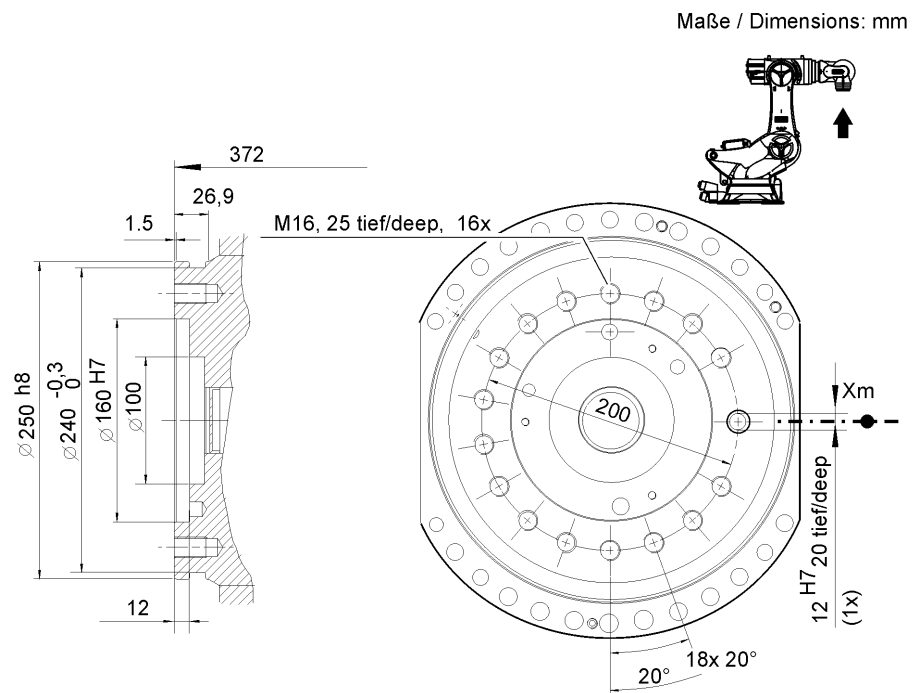

Fig. 4-5: Mounting flange

Supplementary load

The robot can carry supplementary loads on the arm. When mounting the supplementary loads, be careful to observe the maximum permissible total load. If an energy supply system A3 - A6 is used, the maximum supplementary load is reduced by the mass of the energy supply system. The dimensions and positions of the installation options can be seen in the diagram (>>> Fig. 4-6). All other threads and holes on the robot are not suitable for attaching additional loads.

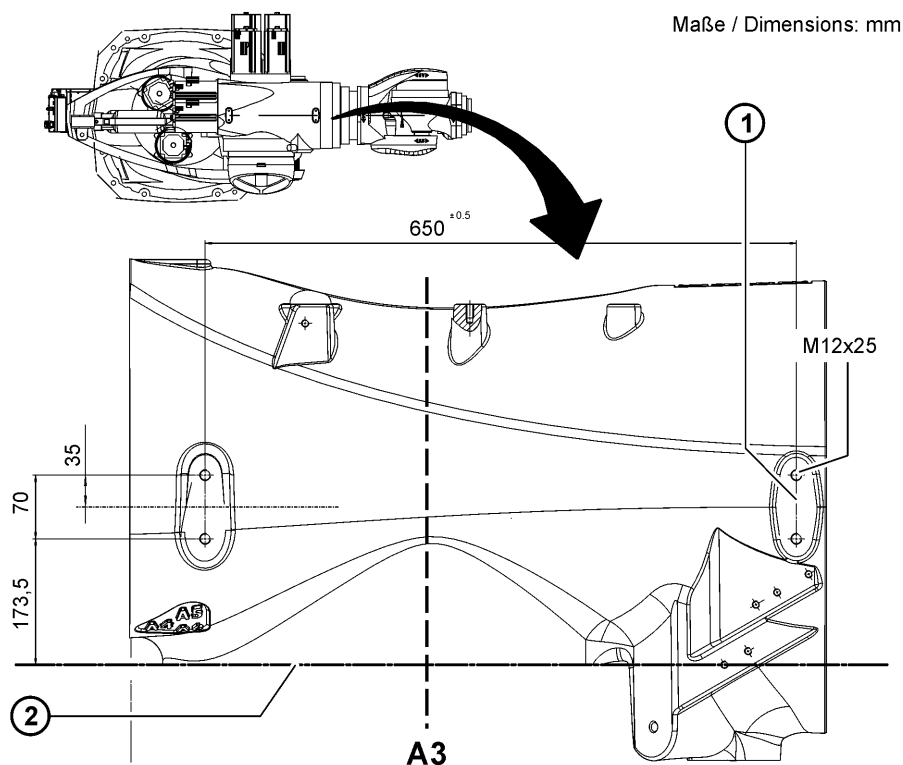

Fig. 4-6: Supplementary load on arm

- 1 Mounting surface on arm
- 2 Interference contour, axis 3

4.5 Payloads, KR 1000 L950 titan PA

Payloads

Robot	KR 1000 L950 titan PA
In-line wrist	IW 750
Rated payload	950 kg
Distance of the load center of gravity L_z	400 mm
Distance of the load center of gravity L_{xy}	150 mm
Permissible moment of inertia	500 kgm ²
Max. total load = Payload + Supplementary load	1,000 kg
Supplementary load, arm	100 kg
Supplementary load, link arm	0 kg
Supplementary load, rotating column	0 kg
Supplementary load, base frame	0 kg

Load center of gravity P

For all payloads, the load center of gravity refers to the distance from the face of the mounting flange on axis 6. Refer to the payload diagram for the nominal distance.

Payload diagram

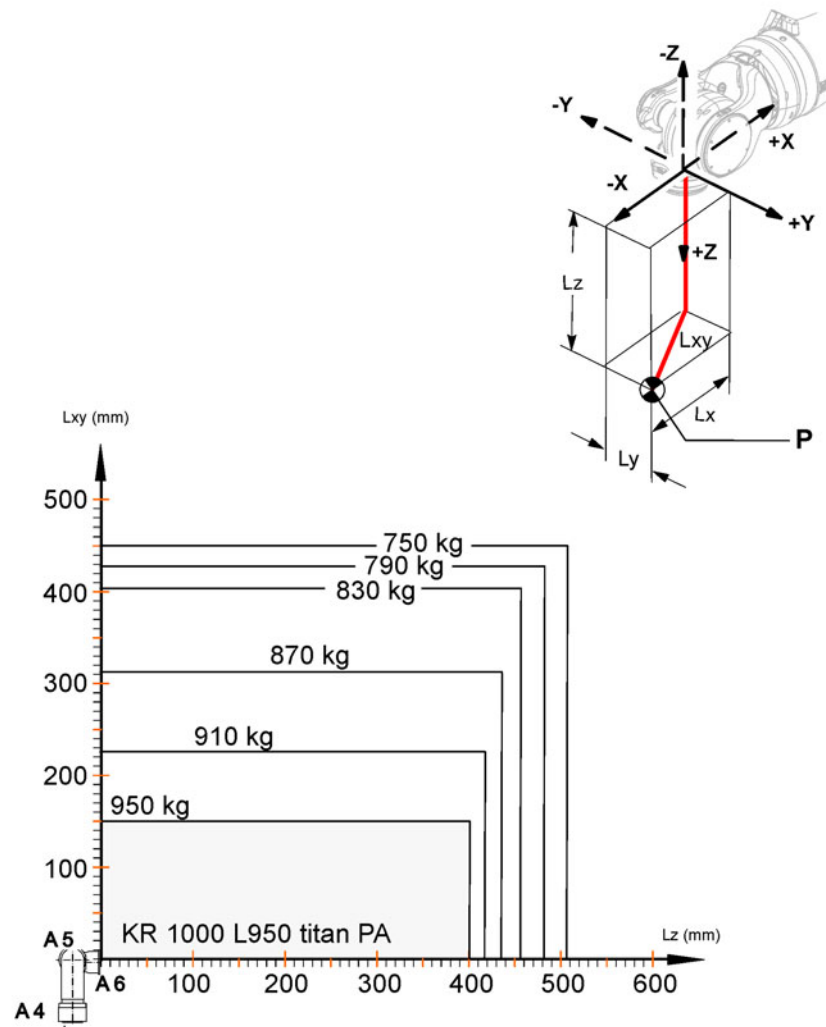

Fig. 4-7: Payload diagram for KR 1000 L950 titan PA

NOTICE

This loading curve corresponds to the maximum load capacity. Both values (payload and mass moment of inertia) must be checked in all cases. Exceeding this capacity will reduce the service life of the robot and overload the motors and the gears; in any such case the KUKA Roboter GmbH must be consulted beforehand.

The values determined here are necessary for planning the robot application. For commissioning the robot, additional input data are required in accordance with operating and programming instructions of the KUKA System Software.

The mass inertia must be verified using KUKA.Load. It is imperative for the load data to be entered in the robot controller!

Mounting flange

Mounting flange	similar to DIN/ISO 9409-1-A200*
Screw grade	10.9
Screw size	M16
Grip length	1.5 x nominal diameter
Depth of engagement	min. 24 mm, max. 25 mm
Locating element	12 ^{H7}

*The inner locating diameter is $\varnothing 160$ ^{H7}. This deviates from the standard.

The mounting flange is depicted (>>> "Mounting flange" Page 23) with axes 4 and 6 in the zero position. The symbol X_m indicates the position of the locating element (bushing) in the zero position.

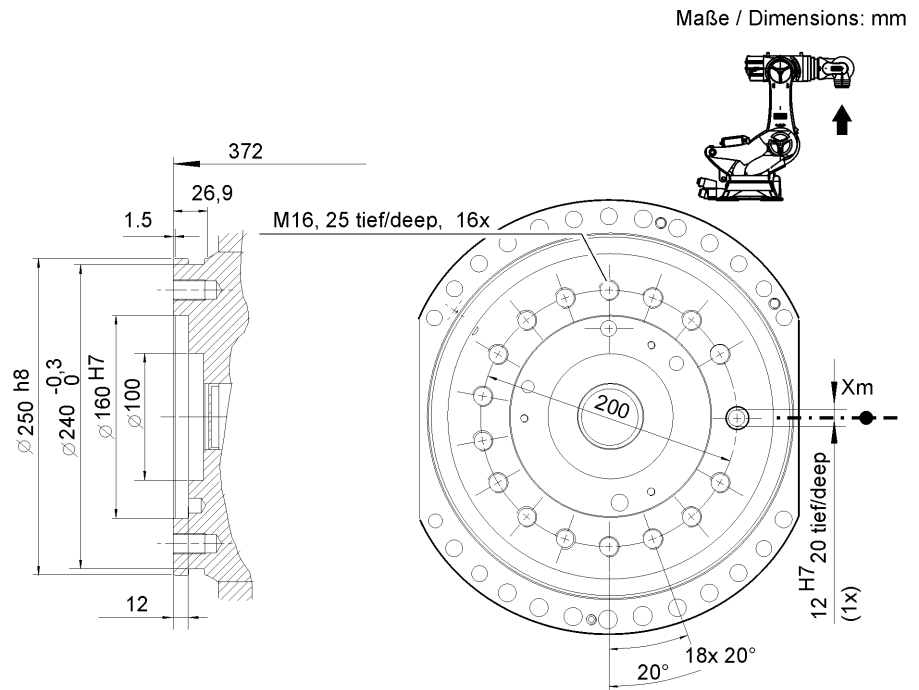

Fig. 4-8: Mounting flange

Supplementary load

The robot can carry supplementary loads on the arm. When mounting the supplementary loads, be careful to observe the maximum permissible total load. If an energy supply system A3 - A6 is used, the maximum supplementary load is reduced by the mass of the energy supply system. The dimensions and positions of the installation options can be seen in the diagram (>>> Fig. 4-9). All other threads and holes on the robot are not suitable for attaching additional loads.

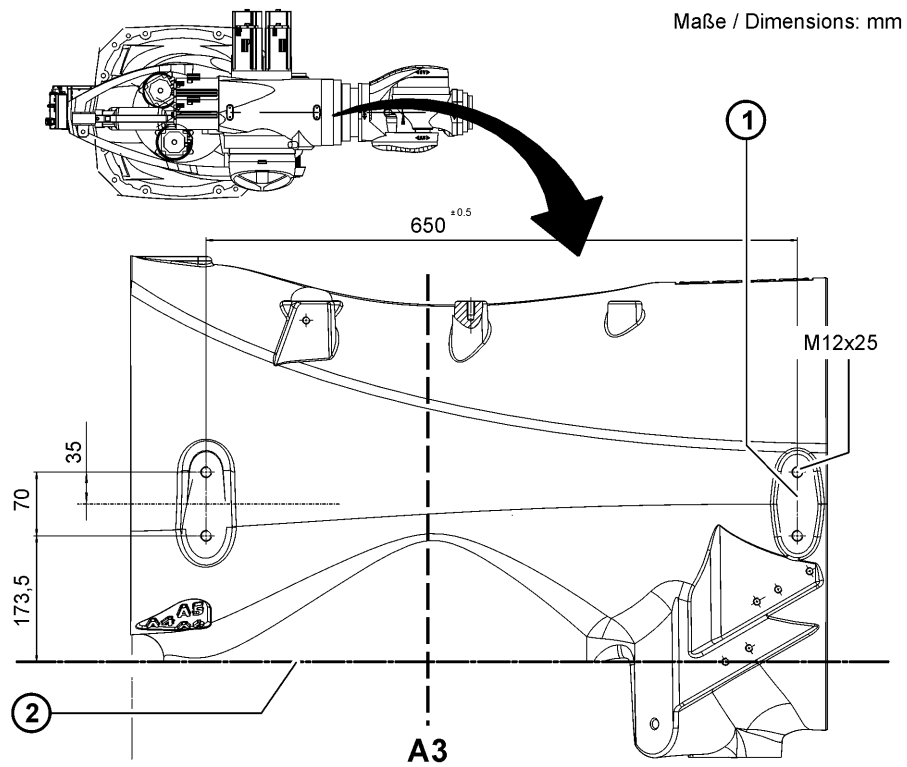

Fig. 4-9: Supplementary load on arm

- 1 Mounting surface on arm
- 2 Interference contour, axis 3

4.6 Foundation data

Loads acting on the mounting base

The specified forces and moments already include the payload and the inertia force (weight) of the robot.

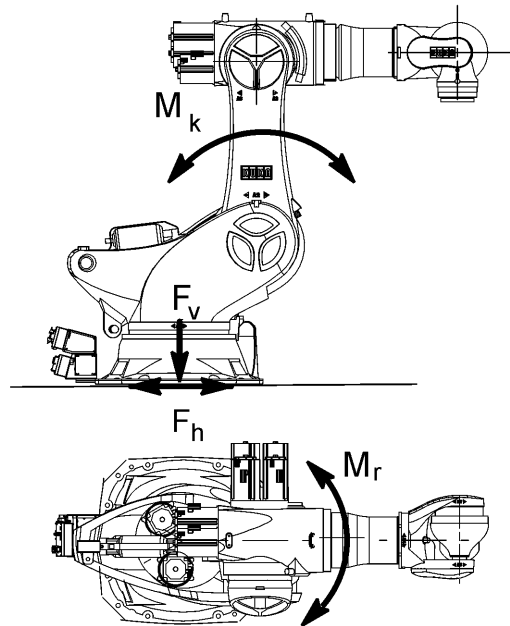

Fig. 4-10: Loads acting on the mounting base

Type of load	Force/torque/mass
F_v = vertical force	$F_{vmax} = 70,000 \text{ N}$
F_h = horizontal force	$F_{hmax} = 35,500 \text{ N}$
M_k = tilting moment	$M_{kmax} = 133,700 \text{ Nm}$
M_r = torque	$M_{rmax} = 99,700 \text{ Nm}$
Total mass for load acting on the mounting base	6,000 kg
Robot	KR 1000 1300 titan PA, 4,690 kg KR 1000 L950 titan, 4,740 kg
Total load for foundation load	1,350 kg for KR 1000 1300 titan PA 1000 kg for KR 1000 L950 titan PA

NOTICE The foundation loads specified in the table are the maximum loads that may occur. They must be referred to when dimensioning the foundations and must be adhered to for safety reasons. Failure to do so may result in material damage. The supplementary loads are not taken into consideration in the calculation of the foundation load. These supplementary loads must be taken into consideration for F_v .

Grade of concrete for foundations

When producing foundations from concrete, observe the load-bearing capacity of the ground and the country-specific construction regulations. There must be no layers of insulation or screed between the bedplates and the concrete foundation. The quality of the concrete must meet the requirements of the following standard:

- C20/25 according to DIN EN 206-1:2001/DIN 1045-2:2008

4.7 Plates and labels

Plates and labels

The following plates and labels are attached to the robot. They must not be removed or rendered illegible. Illegible plates and labels must be replaced.

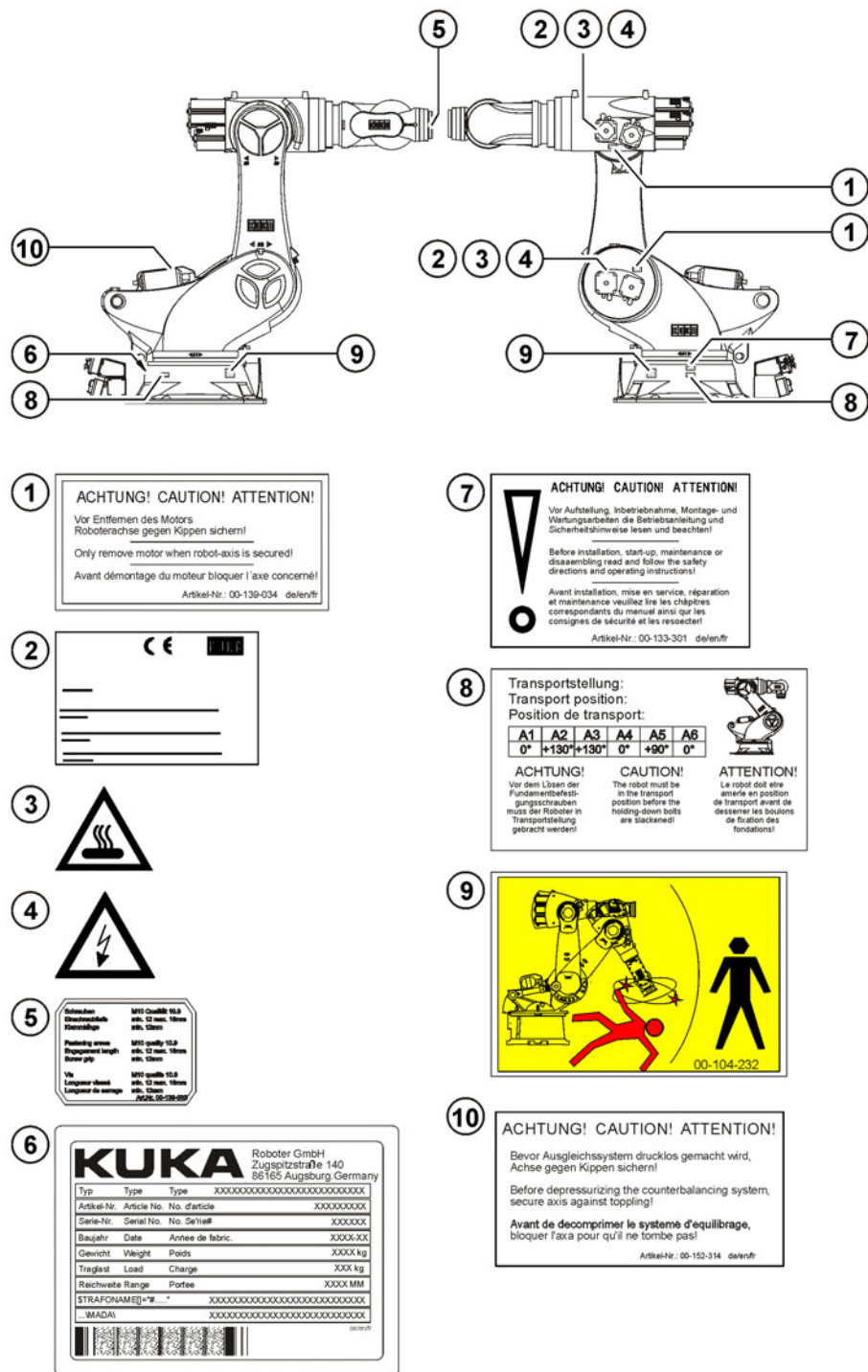

Fig. 4-11: Plates and labels

4.8 Stopping distances and times

4.8.1 General information

Information concerning the data:

- The stopping distance is the angle traveled by the robot from the moment the stop signal is triggered until the robot comes to a complete standstill.
- The stopping time is the time that elapses from the moment the stop signal is triggered until the robot comes to a complete standstill.

- The data are given for the main axes A1, A2 and A3. The main axes are the axes with the greatest deflection.
- Superposed axis motions can result in longer stopping distances.
- Stopping distances and stopping times in accordance with DIN EN ISO 10218-1, Annex B.
- Stop categories:
 - Stop category 0 » STOP 0
 - Stop category 1 » STOP 1 according to IEC 60204-1
- The values specified for Stop 0 are guide values determined by means of tests and simulation. They are average values which conform to the requirements of DIN EN ISO 10218-1. The actual stopping distances and stopping times may differ due to internal and external influences on the braking torque. It is therefore advisable to determine the exact stopping distances and stopping times where necessary under the real conditions of the actual robot application.
- Measuring technique
The stopping distances were measured using the robot-internal measuring technique.
- The wear on the brakes varies depending on the operating mode, robot application and the number of STOP 0 triggered. It is therefore advisable to check the stopping distance at least once a year.

4.8.2 Terms used

Term	Description
m	Mass of the rated load and the supplementary load on the arm.
Phi	Angle of rotation (°) about the corresponding axis. This value can be entered in the controller via the KCP and is displayed on the KCP.
POV	Program override (%) = velocity of the robot motion. This value can be entered in the controller via the KCP and is displayed on the KCP.
Extension	Distance (l in %) (>>> Fig. 4-12) between axis 1 and the intersection of axes 4 and 5. With parallelogram robots, the distance between axis 1 and the intersection of axis 6 and the mounting flange.
KCP	The KCP teach pendant has all the operator control and display functions required for operating and programming the robot system.

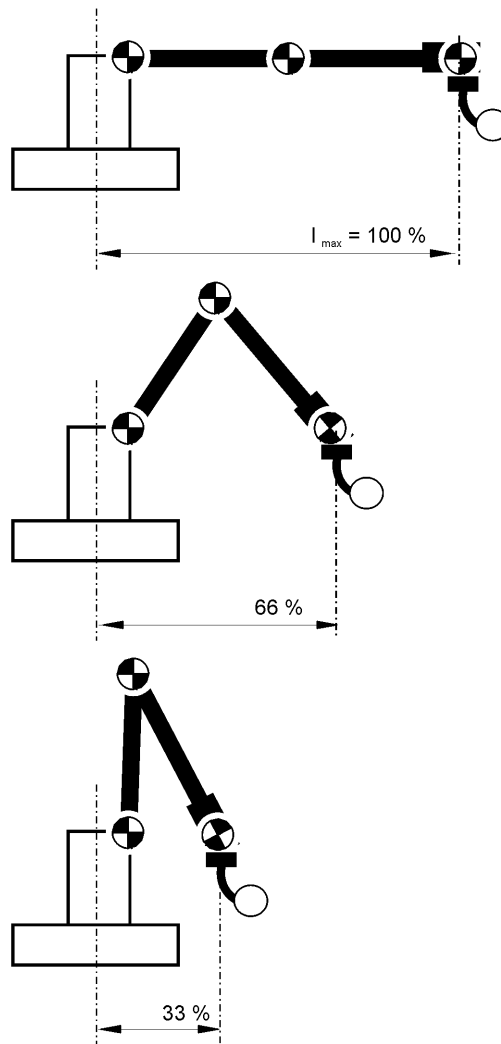

Fig. 4-12: Extension

4.8.3 Stopping distances and times, KR 1000 1300 titan PA

4.8.3.1 Stopping distances and stopping times for STOP 0, axis 1 to axis 3

The table shows the stopping distances and stopping times after a STOP 0 (category 0 stop) is triggered. The values refer to the following configuration:

- Extension $l = 100\%$
- Program override POV = 100%
- Mass $m =$ maximum load (rated load + supplementary load on arm)

	Stopping distance (°)	Stopping time (s)
Axis 1	38.17	1.096
Axis 2	16.70	0.535
Axis 3	14.01	0.359

4.8.3.2 Stopping distances and stopping times for STOP 1, axis 1

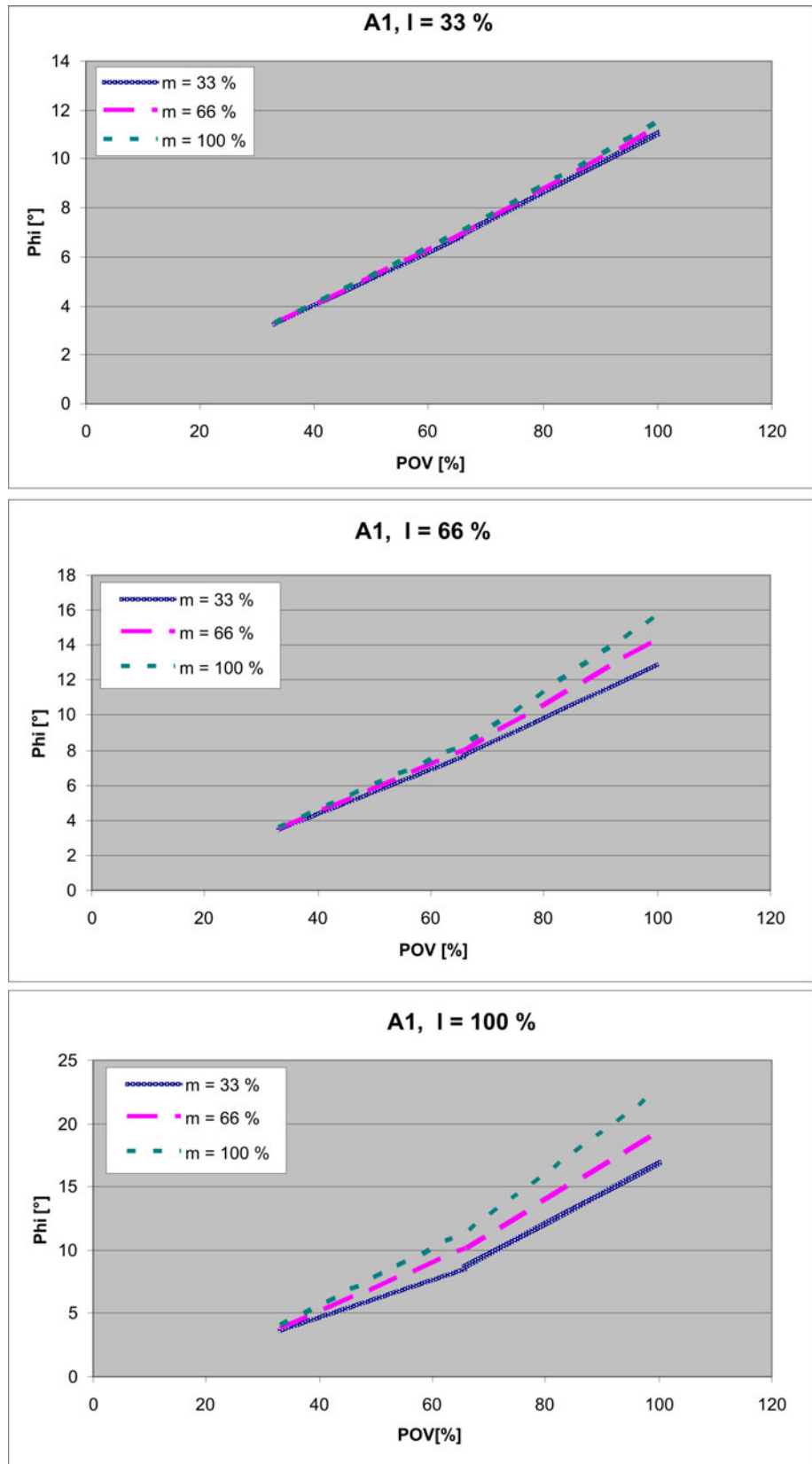

Fig. 4-13: Stopping distances for STOP 1, axis 1

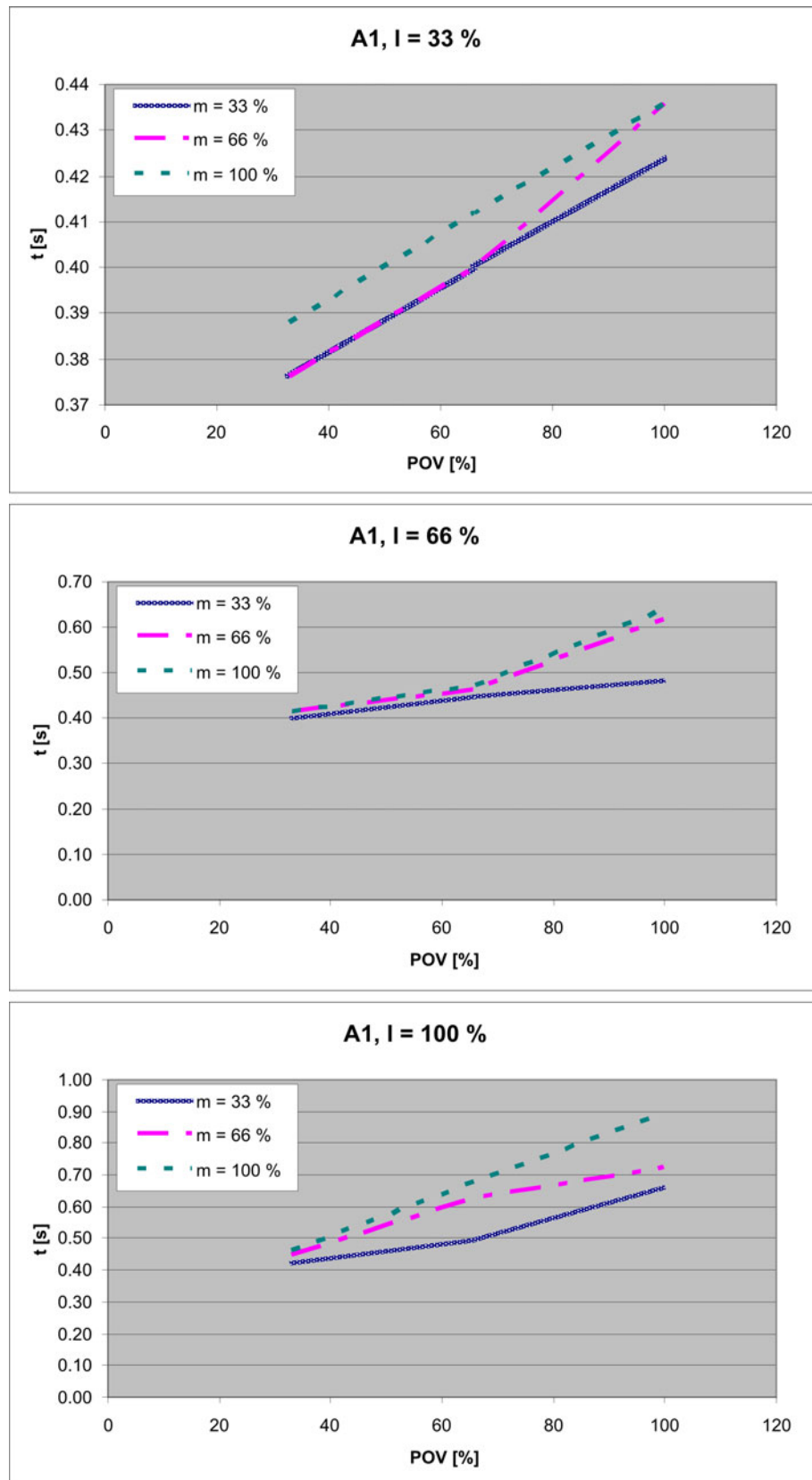

Fig. 4-14: Stopping times for STOP 1, axis 1

4.8.3.3 Stopping distances and stopping times for STOP 1, axis 2

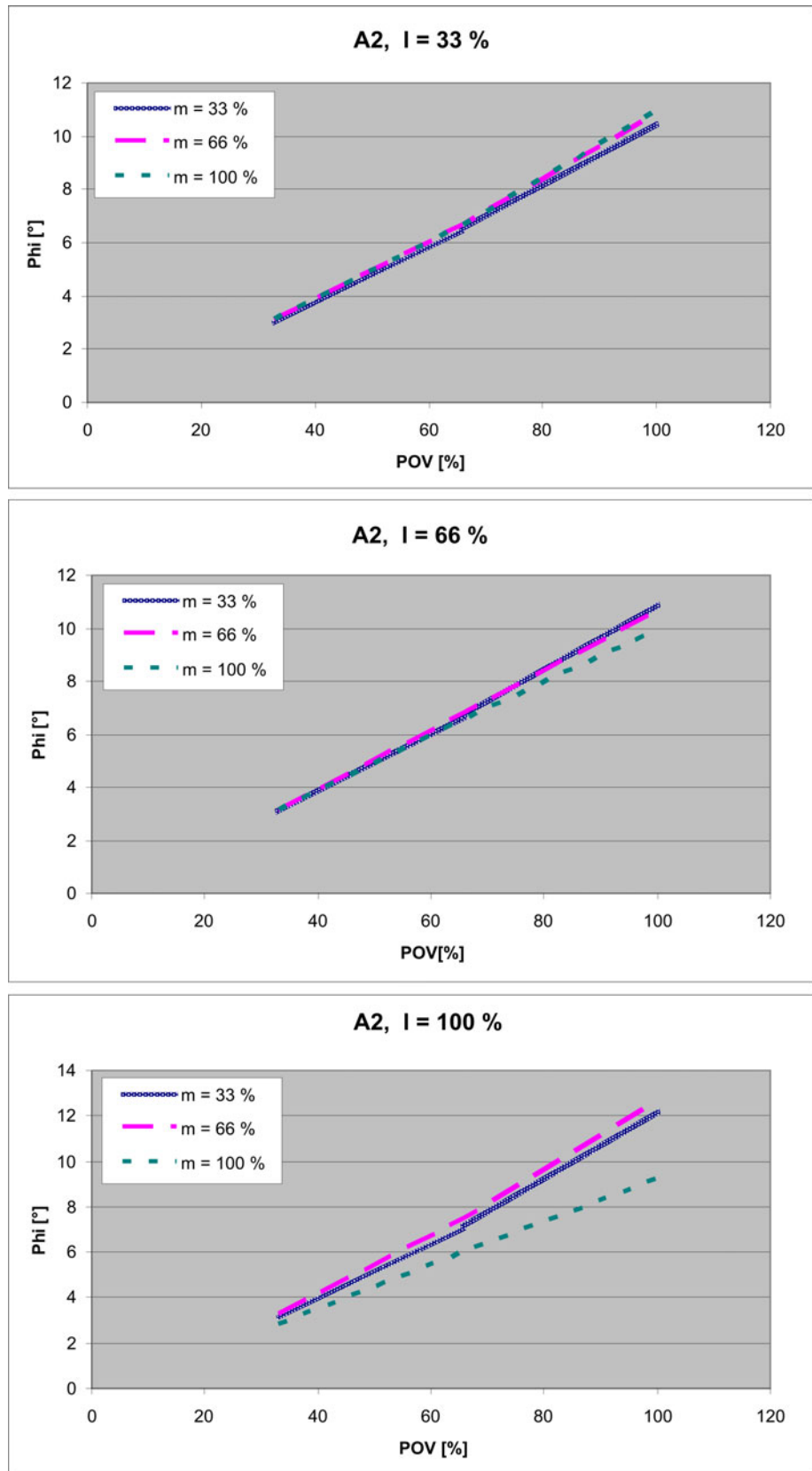

Fig. 4-15: Stopping distances for STOP 1, axis 2

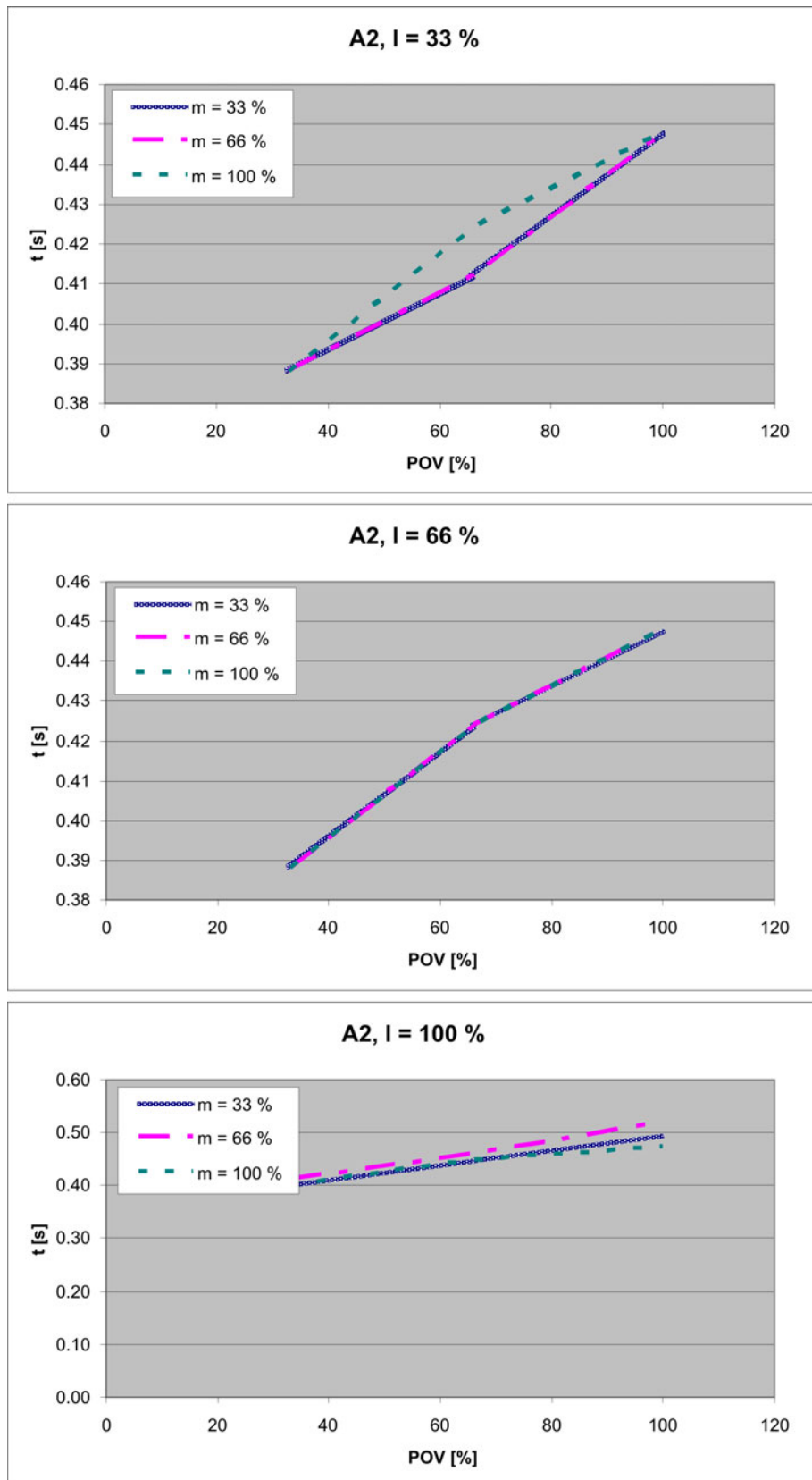

Fig. 4-16: Stopping times for STOP 1, axis 2

4.8.3.4 Stopping distances and stopping times for STOP 1, axis 3

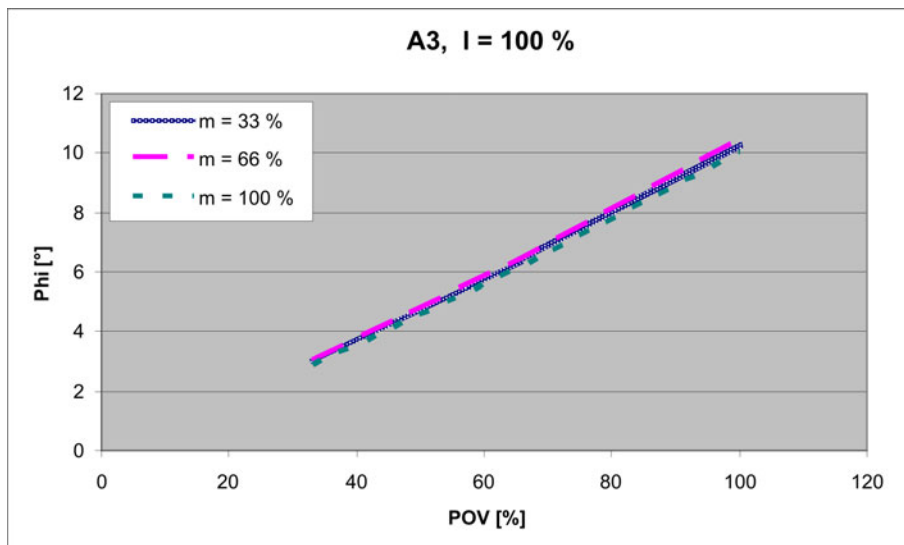

Fig. 4-17: Stopping distances for STOP 1, axis 3

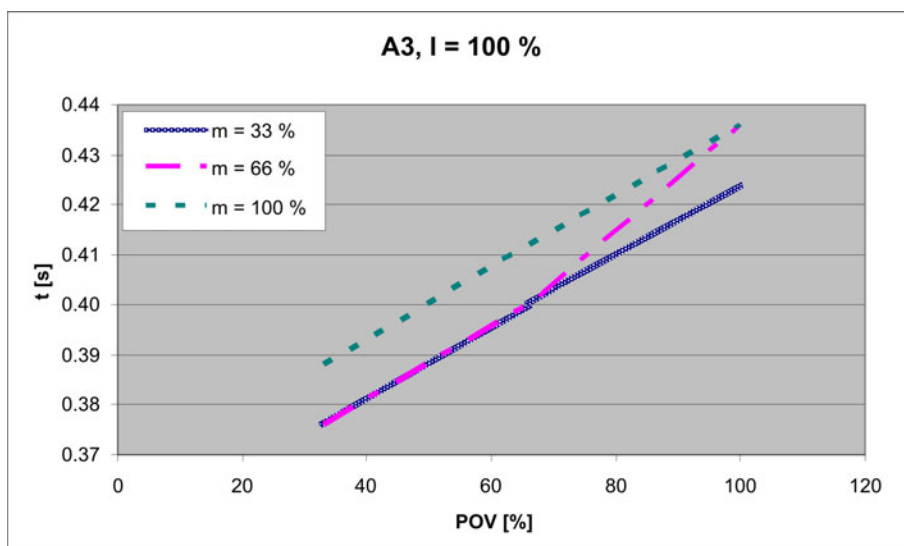

Fig. 4-18: Stopping times for STOP 1, axis 3

4.8.4 Stopping distances and times, KR 1000 L950 titan PA

4.8.4.1 Stopping distances and stopping times for STOP 0, axis 1 to axis 3

The table shows the stopping distances and stopping times after a STOP 0 (category 0 stop) is triggered. The values refer to the following configuration:

- Extension l = 100%
- Program override POV = 100%
- Mass m = maximum load (rated load + supplementary load on arm)

	Stopping distance (°)	Stopping time (s)
Axis 1	39.58	1.119
Axis 2	17.67	0.556
Axis 3	14.71	0.386

4.8.4.2 Stopping distances and stopping times for STOP 1, axis 1

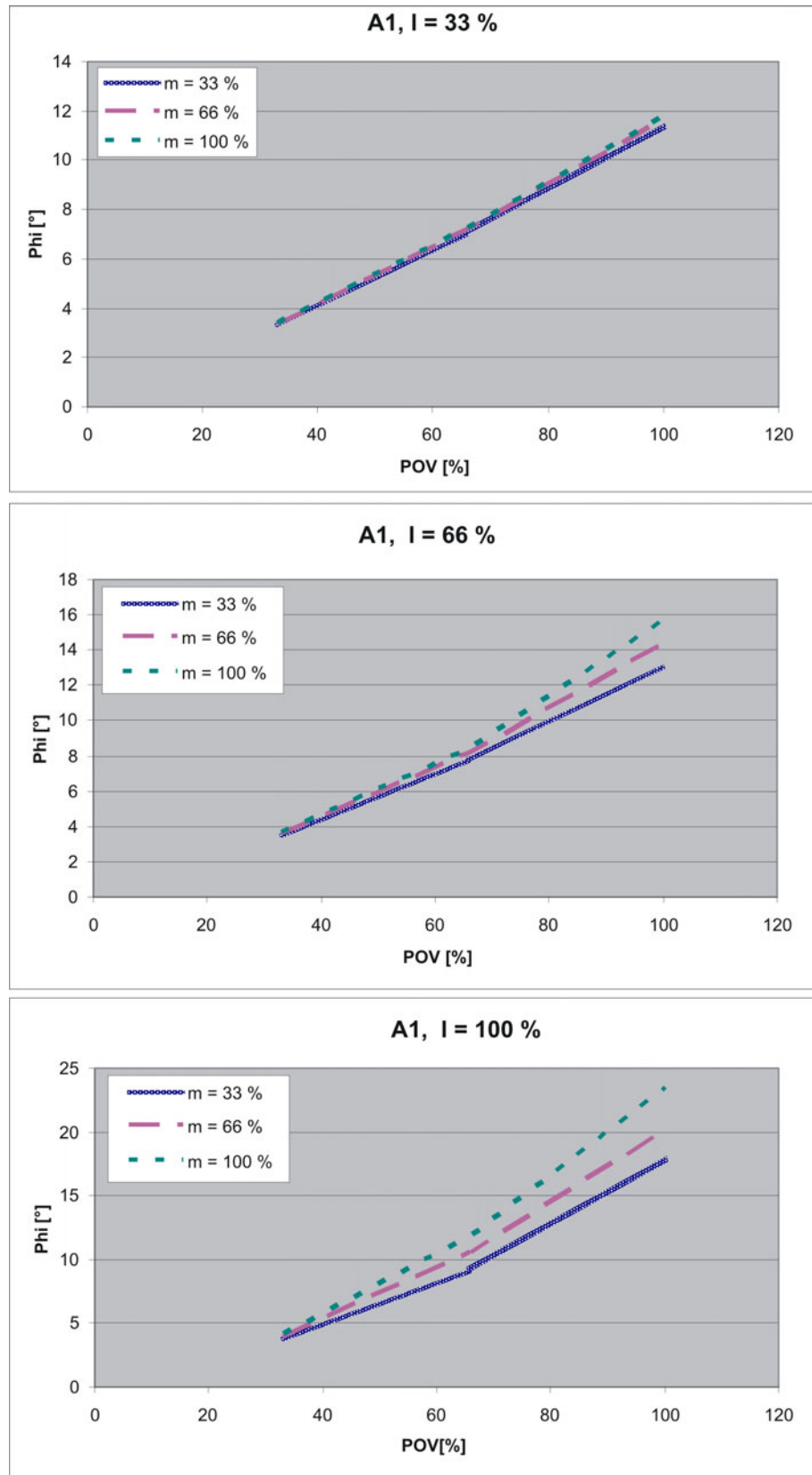

Fig. 4-19: Stopping distances for STOP 1, axis 1

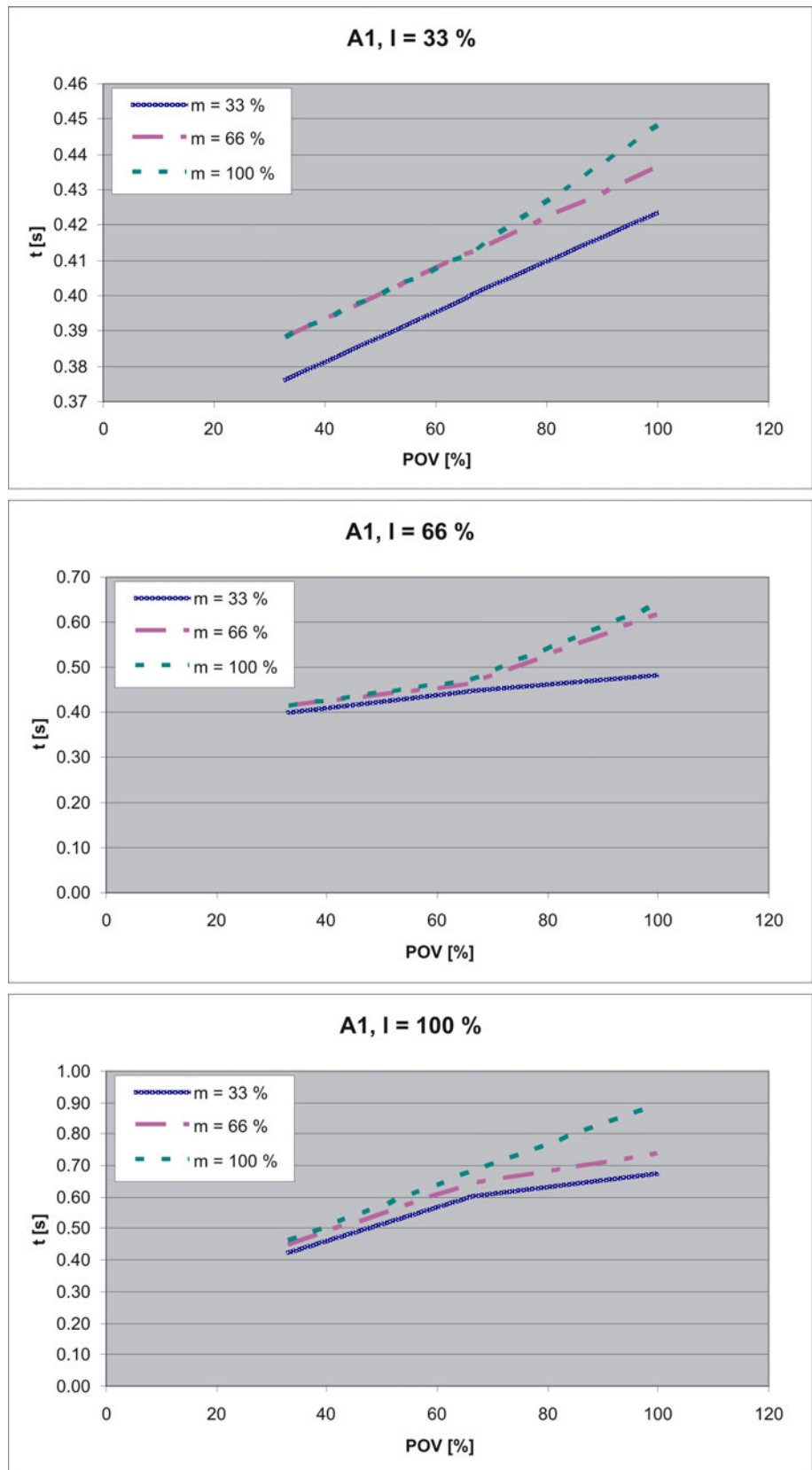

Fig. 4-20: Stopping times for STOP 1, axis 1

4.8.4.3 Stopping distances and stopping times for STOP 1, axis 2

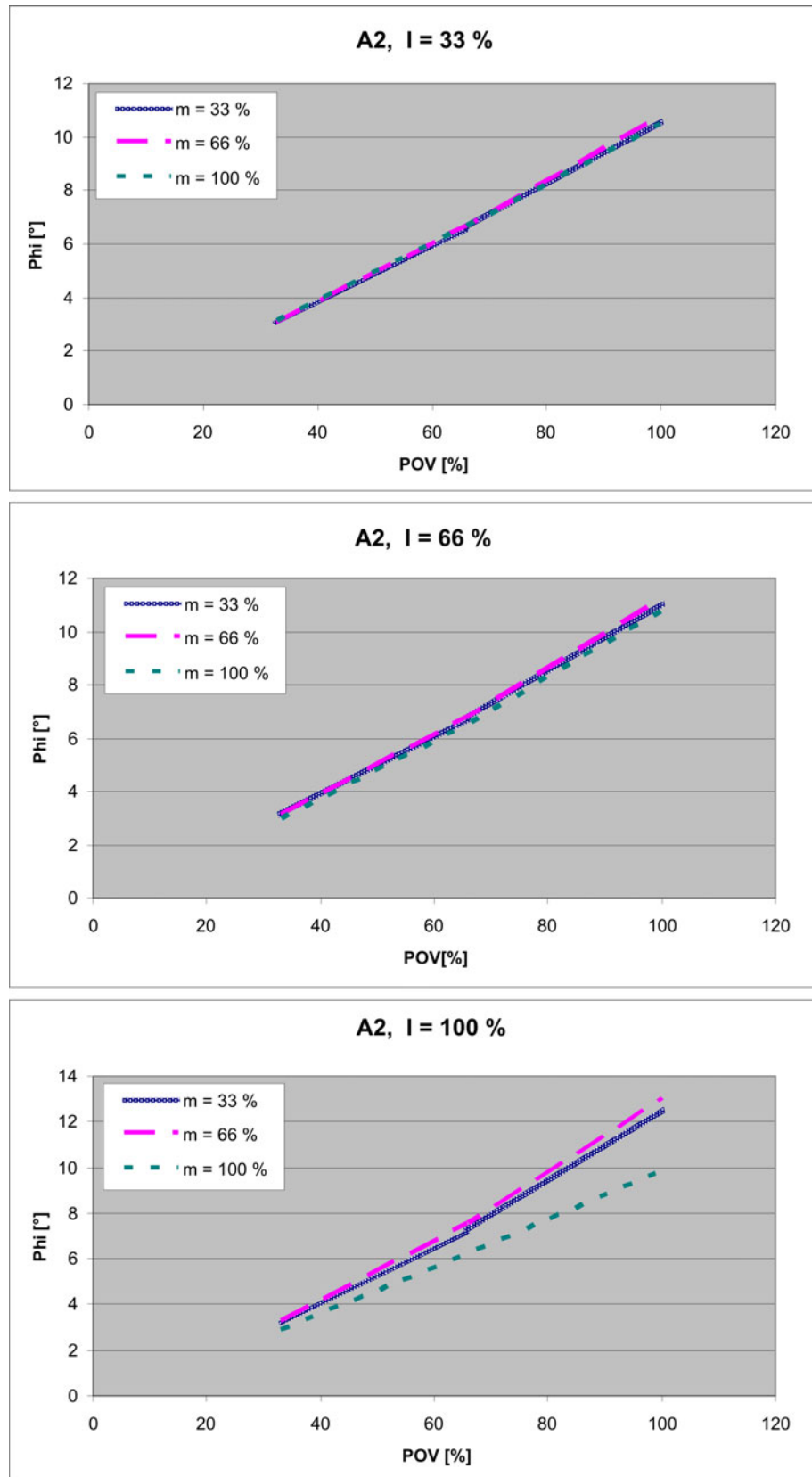

Fig. 4-21: Stopping distances for STOP 1, axis 2

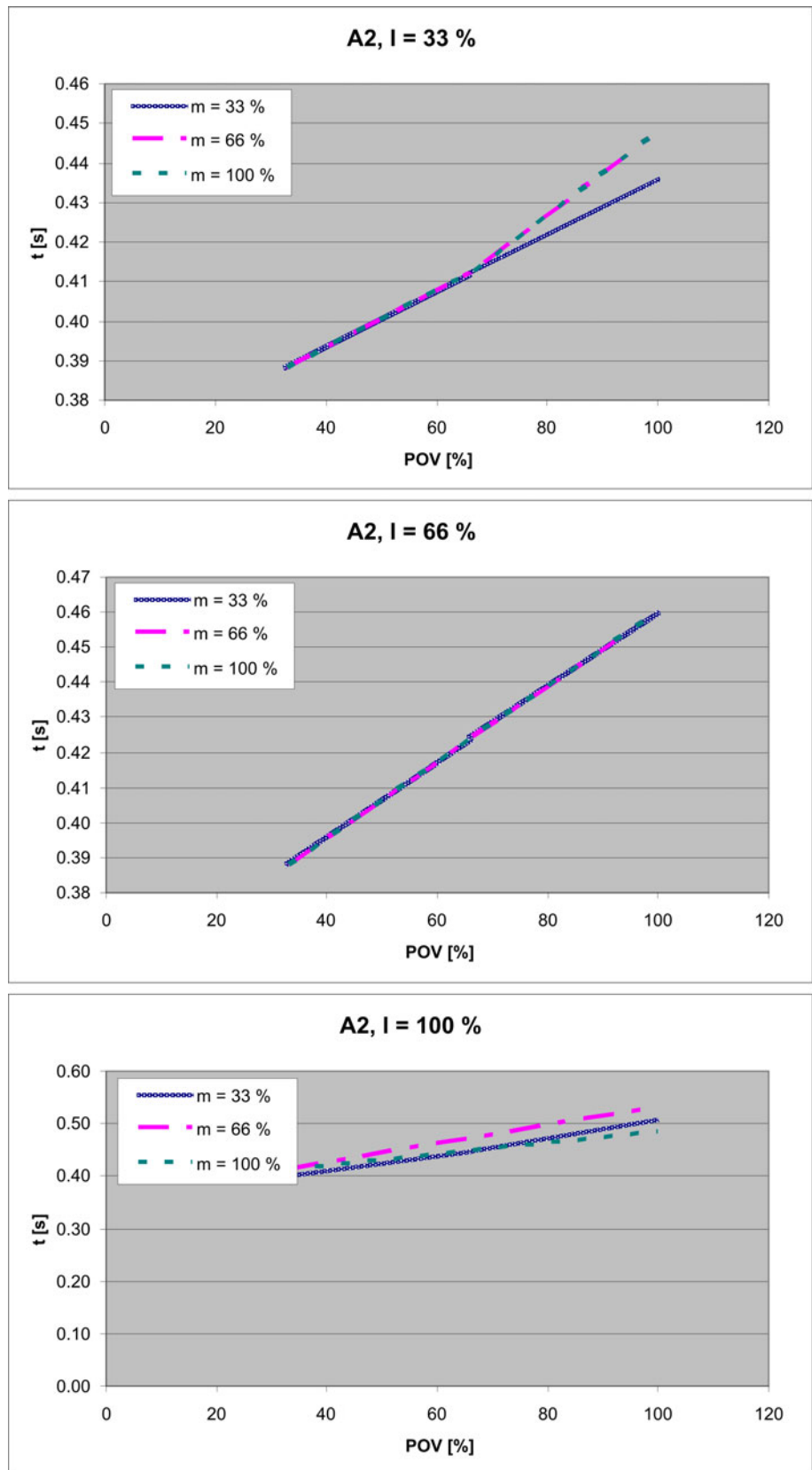

Fig. 4-22: Stopping times for STOP 1, axis 2

4.8.4.4 Stopping distances and stopping times for STOP 1, axis 3

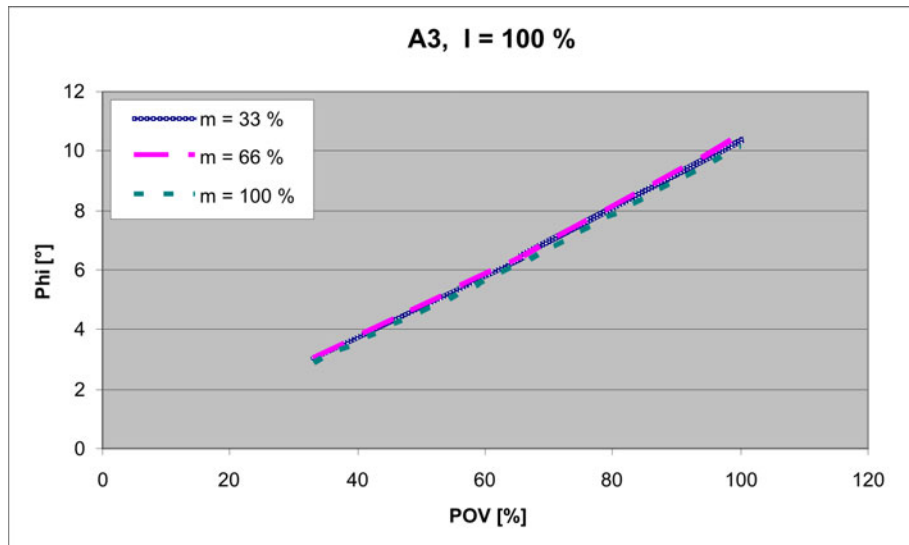

Fig. 4-23: Stopping distances for STOP 1, axis 3

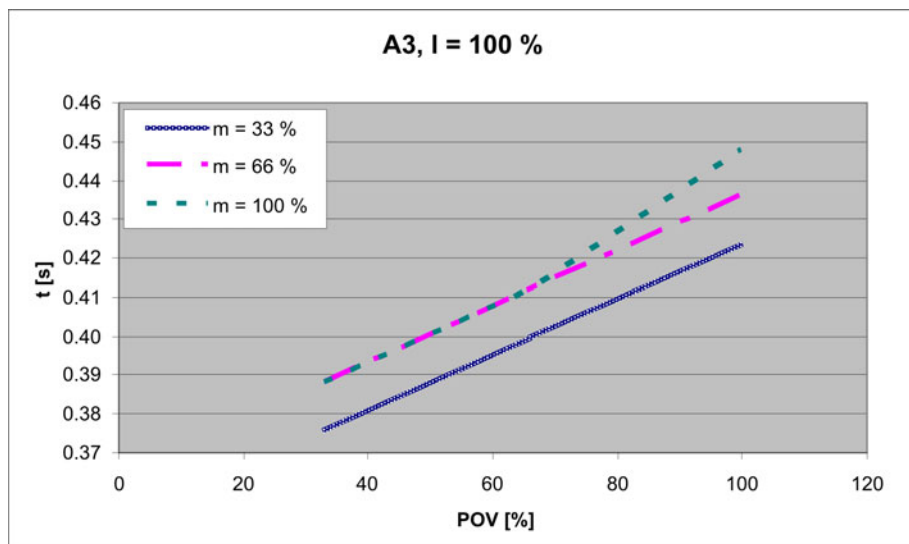

Fig. 4-24: Stopping times for STOP 1, axis 3

5 Safety

5.1 General



■ This “Safety” chapter refers to a mechanical component of an industrial robot.

■ If the mechanical component is used together with a KUKA robot controller, the “Safety” chapter of the operating instructions or assembly instructions of the robot controller must be used!

This contains all the information provided in this “Safety” chapter. It also contains additional safety information relating to the robot controller which must be observed.

■ Where this “Safety” chapter uses the term “industrial robot”, this also refers to the individual mechanical component if applicable.

5.1.1 Liability

The device described in this document is either an industrial robot or a component thereof.

Components of the industrial robot:

- Manipulator
- Robot controller
- Teach pendant
- Connecting cables
- External axes (optional)
e.g. linear unit, turn-tilt table, positioner
- Software
- Options, accessories

The industrial robot is built using state-of-the-art technology and in accordance with the recognized safety rules. Nevertheless, misuse of the industrial robot may constitute a risk to life and limb or cause damage to the industrial robot and to other material property.

The industrial robot may only be used in perfect technical condition in accordance with its designated use and only by safety-conscious persons who are fully aware of the risks involved in its operation. Use of the industrial robot is subject to compliance with this document and with the declaration of incorporation supplied together with the industrial robot. Any functional disorders affecting safety must be rectified immediately.

Safety information

Safety information cannot be held against KUKA Roboter GmbH. Even if all safety instructions are followed, this is not a guarantee that the industrial robot will not cause personal injuries or material damage.

No modifications may be carried out to the industrial robot without the authorization of KUKA Roboter GmbH. Additional components (tools, software, etc.), not supplied by KUKA Roboter GmbH, may be integrated into the industrial robot. The user is liable for any damage these components may cause to the industrial robot or to other material property.

In addition to the Safety chapter, this document contains further safety instructions. These must also be observed.

5.1.2 Intended use of the industrial robot

The industrial robot is intended exclusively for the use designated in the “Purpose” chapter of the operating instructions or assembly instructions.



Further information is contained in the “Purpose” chapter of the operating instructions or assembly instructions of the industrial robot.

Using the industrial robot for any other or additional purpose is considered impermissible misuse. The manufacturer cannot be held liable for any damage resulting from such use. The risk lies entirely with the user.

Operating the industrial robot and its options within the limits of its intended use also involves observance of the operating and assembly instructions for the individual components, with particular reference to the maintenance specifications.

Misuse

Any use or application deviating from the intended use is deemed to be impermissible misuse. This includes e.g.:

- Transportation of persons and animals
- Use as a climbing aid
- Operation outside the permissible operating parameters
- Use in potentially explosive environments
- Operation without additional safeguards
- Outdoor operation
- Underground operation

5.1.3 EC declaration of conformity and declaration of incorporation

This industrial robot constitutes partly completed machinery as defined by the EC Machinery Directive. The industrial robot may only be put into operation if the following preconditions are met:

- The industrial robot is integrated into a complete system.
Or: The industrial robot, together with other machinery, constitutes a complete system.
Or: All safety functions and safeguards required for operation in the complete machine as defined by the EC Machinery Directive have been added to the industrial robot.
- The complete system complies with the EC Machinery Directive. This has been confirmed by means of an assessment of conformity.

Declaration of conformity

The system integrator must issue a declaration of conformity for the complete system in accordance with the Machinery Directive. The declaration of conformity forms the basis for the CE mark for the system. The industrial robot must be operated in accordance with the applicable national laws, regulations and standards.

The robot controller is CE certified under the EMC Directive and the Low Voltage Directive.

Declaration of incorporation

The industrial robot as partly completed machinery is supplied with a declaration of incorporation in accordance with Annex II B of the EC Machinery Directive 2006/42/EC. The assembly instructions and a list of essential requirements complied with in accordance with Annex I are integral parts of this declaration of incorporation.

The declaration of incorporation declares that the start-up of the partly completed machinery remains impermissible until the partly completed machinery

has been incorporated into machinery, or has been assembled with other parts to form machinery, and this machinery complies with the terms of the EC Machinery Directive, and the EC declaration of conformity is present in accordance with Annex II A.

The declaration of incorporation, together with its annexes, remains with the system integrator as an integral part of the technical documentation of the complete machinery.

5.1.4 Terms used

Term	Description
Axis range	Range of each axis, in degrees or millimeters, within which it may move. The axis range must be defined for each axis.
Stopping distance	Stopping distance = reaction distance + braking distance The stopping distance is part of the danger zone.
Workspace	The manipulator is allowed to move within its workspace. The workspace is derived from the individual axis ranges.
Operator (User)	The user of the industrial robot can be the management, employer or delegated person responsible for use of the industrial robot.
Danger zone	The danger zone consists of the workspace and the stopping distances.
Service life	The service life of a safety-relevant component begins at the time of delivery of the component to the customer. The service life is not affected by whether the component is used in a robot controller or elsewhere or not, as safety-relevant components are also subject to ageing during storage.
KCP	The KCP (KUKA Control Panel) teach pendant has all the operator control and display functions required for operating and programming the industrial robot. The KCP variant for the KR C4 is called KUKA smartPAD. The general term "KCP", however, is generally used in this documentation.
KUKA smartPAD	See KCP
Manipulator	The robot arm and the associated electrical installations
Safety zone	The safety zone is situated outside the danger zone.
Stop category 0	The drives are deactivated immediately and the brakes are applied. The manipulator and any external axes (optional) perform path-oriented braking. Note: This stop category is called STOP 0 in this document.
Stop category 1	The manipulator and any external axes (optional) perform path-maintaining braking. The drives are deactivated after 1 s and the brakes are applied. Note: This stop category is called STOP 1 in this document.
Stop category 2	The drives are not deactivated and the brakes are not applied. The manipulator and any external axes (optional) are braked with a normal braking ramp. Note: This stop category is called STOP 2 in this document.
System integrator (plant integrator)	System integrators are people who safely integrate the industrial robot into a complete system and commission it.
T1	Test mode, Manual Reduced Velocity (≤ 250 mm/s)
T2	Test mode, Manual High Velocity (> 250 mm/s permissible)
External axis	Motion axis which is not part of the manipulator but which is controlled using the robot controller, e.g. KUKA linear unit, turn-tilt table, Posiflex.

5.2 Personnel

The following persons or groups of persons are defined for the industrial robot:

- User
- Personnel



All persons working with the industrial robot must have read and understood the industrial robot documentation, including the safety chapter.

User

The user must observe the labor laws and regulations. This includes e.g.:

- The user must comply with his monitoring obligations.
- The user must carry out instructions at defined intervals.

Personnel

Personnel must be instructed, before any work is commenced, in the type of work involved and what exactly it entails as well as any hazards which may exist. Instruction must be carried out regularly. Instruction is also required after particular incidents or technical modifications.

Personnel includes:

- System integrator
- Operators, subdivided into:
 - Start-up, maintenance and service personnel
 - Operating personnel
 - Cleaning personnel



Installation, exchange, adjustment, operation, maintenance and repair must be performed only as specified in the operating or assembly instructions for the relevant component of the industrial robot and only by personnel specially trained for this purpose.

System integrator

The industrial robot is safely integrated into a complete system by the system integrator.

The system integrator is responsible for the following tasks:

- Installing the industrial robot
- Connecting the industrial robot
- Performing risk assessment
- Implementing the required safety functions and safeguards
- Issuing the declaration of conformity
- Attaching the CE mark
- Creating the operating instructions for the complete system

Operator

The operator must meet the following preconditions:

- The operator must be trained for the work to be carried out.
- Work on the industrial robot must only be carried out by qualified personnel. These are people who, due to their specialist training, knowledge and experience, and their familiarization with the relevant standards, are able to assess the work to be carried out and detect any potential hazards.

Example

The tasks can be distributed as shown in the following table.

Tasks	Operator	Programmer	System integrator
Switch robot controller on/off	x	x	x
Start program	x	x	x
Select program	x	x	x
Select operating mode	x	x	x
Calibration (tool, base)		x	x
Master the manipulator		x	x
Configuration		x	x
Programming		x	x
Start-up			x
Maintenance			x
Repair			x
Shutting down			x
Transportation			x



Work on the electrical and mechanical equipment of the industrial robot may only be carried out by specially trained personnel.

5.3 Workspace, safety zone and danger zone

Workspaces are to be restricted to the necessary minimum size. A workspace must be safeguarded using appropriate safeguards.

The safeguards (e.g. safety gate) must be situated inside the safety zone. In the case of a stop, the manipulator and external axes (optional) are braked and come to a stop within the danger zone.

The danger zone consists of the workspace and the stopping distances of the manipulator and external axes (optional). It must be safeguarded by means of physical safeguards to prevent danger to persons or the risk of material damage.

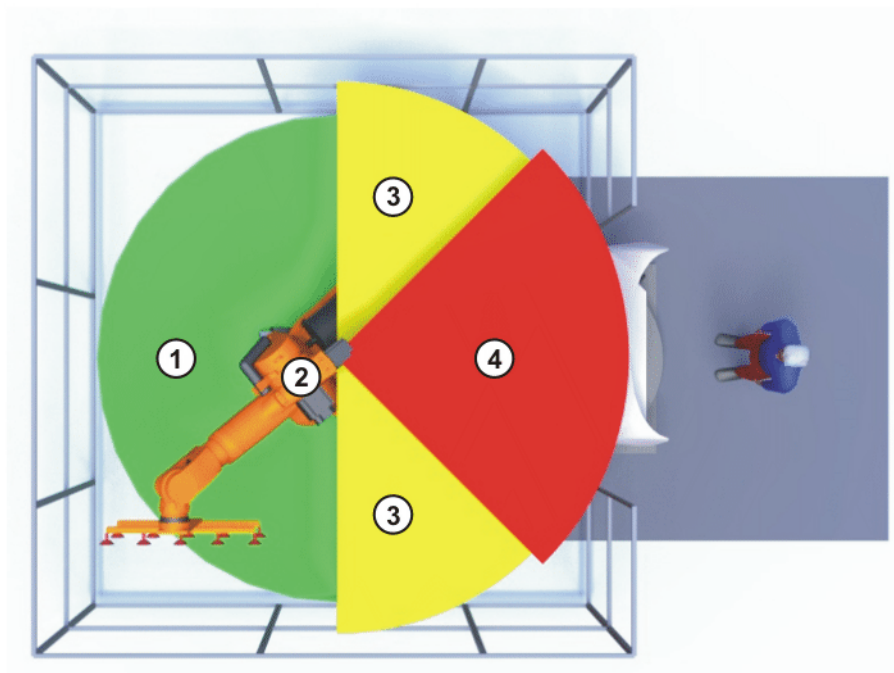

Fig. 5-1: Example of axis range A1

- | | | | |
|---|-------------|---|-------------------|
| 1 | Workspace | 3 | Stopping distance |
| 2 | Manipulator | 4 | Safety zone |

5.4 Overview of protective equipment

The protective equipment of the mechanical component may include:

- Mechanical end stops
- Mechanical axis range limitation (optional)
- Axis range monitoring (optional)
- Release device (optional)
- Labeling of danger areas

Not all equipment is relevant for every mechanical component.

5.4.1 Mechanical end stops

Depending on the robot variant, the axis ranges of the main and wrist axes of the manipulator are partially limited by mechanical end stops.

Additional mechanical end stops can be installed on the external axes.

WARNING If the manipulator or an external axis hits an obstruction or a mechanical end stop or axis range limitation, this can result in material damage to the industrial robot. The manipulator must be taken out of operation and KUKA Roboter GmbH must be consulted before it is put back into operation (>>> 8 "KUKA Service" Page 67).

5.4.2 Mechanical axis range limitation (optional)

Some manipulators can be fitted with mechanical axis range limitation in axes A1 to A3. The adjustable axis range limitation systems restrict the working range to the required minimum. This increases personal safety and protection of the system.

In the case of manipulators that are not designed to be fitted with mechanical axis range limitation, the workspace must be laid out in such a way that there is no danger to persons or material property, even in the absence of mechanical axis range limitation.

If this is not possible, the workspace must be limited by means of photoelectric barriers, photoelectric curtains or obstacles on the system side. There must be no shearing or crushing hazards at the loading and transfer areas.

 This option is not available for all robot models. Information on specific robot models can be obtained from KUKA Roboter GmbH.

5.4.3 Axis range monitoring (optional)

Some manipulators can be fitted with dual-channel axis range monitoring systems in main axes A1 to A3. The positioner axes may be fitted with additional axis range monitoring systems. The safety zone for an axis can be adjusted and monitored using an axis range monitoring system. This increases personal safety and protection of the system.

 This option is not available for all robot models. Information on specific robot models can be obtained from KUKA Roboter GmbH.

5.4.4 Options for moving the manipulator without drive energy

 The system user is responsible for ensuring that the training of personnel with regard to the response to emergencies or exceptional situations also includes how the manipulator can be moved without drive energy.

Description

The following options are available for moving the manipulator without drive energy after an accident or malfunction:

- Release device (optional)
The release device can be used for the main axis drive motors and, depending on the robot variant, also for the wrist axis drive motors.
- Brake release device (option)
The brake release device is designed for robot variants whose motors are not freely accessible.
- Moving the wrist axes directly by hand
There is no release device available for the wrist axes of variants in the low payload category. This is not necessary because the wrist axes can be moved directly by hand.

 Information about the options available for the various robot models and about how to use them can be found in the assembly and operating instructions for the robot or requested from KUKA Roboter GmbH.

NOTICE Moving the manipulator without drive energy can damage the motor brakes of the axes concerned. The motor must be replaced if the brake has been damaged. The manipulator may therefore be moved without drive energy only in emergencies or exceptional situations, e.g. for rescuing persons.

5.4.5 Labeling on the industrial robot

All plates, labels, symbols and marks constitute safety-relevant parts of the industrial robot. They must not be modified or removed.

Labeling on the industrial robot consists of:

- Identification plates
- Warning labels
- Safety symbols
- Designation labels
- Cable markings
- Rating plates

	Further information is contained in the technical data of the operating instructions or assembly instructions of the components of the industrial robot.
---	--

5.5 Safety measures

5.5.1 General safety measures

The industrial robot may only be used in perfect technical condition in accordance with its intended use and only by safety-conscious persons. Operator errors can result in personal injury and damage to property.

It is important to be prepared for possible movements of the industrial robot even after the robot controller has been switched off and locked. Incorrect installation (e.g. overload) or mechanical defects (e.g. brake defect) can cause the manipulator or external axes to sag. If work is to be carried out on a switched-off industrial robot, the manipulator and external axes must first be moved into a position in which they are unable to move on their own, whether the payload is mounted or not. If this is not possible, the manipulator and external axes must be secured by appropriate means.

 DANGER	In the absence of operational safety functions and safeguards, the industrial robot can cause personal injury or material damage. If safety functions or safeguards are dismantled or deactivated, the industrial robot may not be operated.
---	--

 DANGER	Standing underneath the robot arm can cause death or serious injuries. For this reason, standing underneath the robot arm is prohibited!
---	--

 CAUTION	The motors reach temperatures during operation which can cause burns to the skin. Contact must be avoided. Appropriate safety precautions must be taken, e.g. protective gloves must be worn.
--	---

KCP

The user must ensure that the industrial robot is only operated with the KCP by authorized persons.

If more than one KCP is used in the overall system, it must be ensured that each KCP is unambiguously assigned to the corresponding industrial robot. They must not be interchanged.

⚠ WARNING The operator must ensure that decoupled KCPs are immediately removed from the system and stored out of sight and reach of personnel working on the industrial robot. This serves to prevent operational and non-operational EMERGENCY STOP devices from becoming interchanged. Failure to observe this precaution may result in death, severe injuries or considerable damage to property.

External keyboard, external mouse

An external keyboard and/or external mouse may only be used if the following conditions are met:

- Start-up or maintenance work is being carried out.
- The drives are switched off.
- There are no persons in the danger zone.

The KCP must not be used as long as an external keyboard and/or external mouse are connected.

The external keyboard and/or external mouse must be removed as soon as the start-up or maintenance work is completed or the KCP is connected.

Faults

The following tasks must be carried out in the case of faults in the industrial robot:

- Switch off the robot controller and secure it (e.g. with a padlock) to prevent unauthorized persons from switching it on again.
- Indicate the fault by means of a label with a corresponding warning (tag-out).
- Keep a record of the faults.
- Eliminate the fault and carry out a function test.

Modifications

After modifications to the industrial robot, checks must be carried out to ensure the required safety level. The valid national or regional work safety regulations must be observed for this check. The correct functioning of all safety circuits must also be tested.

New or modified programs must always be tested first in Manual Reduced Velocity mode (T1).

After modifications to the industrial robot, existing programs must always be tested first in Manual Reduced Velocity mode (T1). This applies to all components of the industrial robot and includes modifications to the software and configuration settings.

5.5.2 Transportation

Manipulator

The prescribed transport position of the manipulator must be observed. Transportation must be carried out in accordance with the operating instructions or assembly instructions of the robot.

Robot controller

The prescribed transport position of the robot controller must be observed. Transportation must be carried out in accordance with the operating instructions or assembly instructions of the robot controller.

Avoid vibrations and impacts during transportation in order to prevent damage to the robot controller.

External axis (optional)

The prescribed transport position of the external axis (e.g. KUKA linear unit, turn-tilt table, positioner) must be observed. Transportation must be carried out in accordance with the operating instructions or assembly instructions of the external axis.

5.5.3 Start-up and recommissioning

Before starting up systems and devices for the first time, a check must be carried out to ensure that the systems and devices are complete and operational, that they can be operated safely and that any damage is detected.

The valid national or regional work safety regulations must be observed for this check. The correct functioning of all safety circuits must also be tested.



The passwords for logging onto the KUKA System Software as “Expert” and “Administrator” must be changed before start-up and must only be communicated to authorized personnel.



The robot controller is preconfigured for the specific industrial robot. If cables are interchanged, the manipulator and the external axes (optional) may receive incorrect data and can thus cause personal injury or material damage. If a system consists of more than one manipulator, always connect the connecting cables to the manipulators and their corresponding robot controllers.



If additional components (e.g. cables), which are not part of the scope of supply of KUKA Roboter GmbH, are integrated into the industrial robot, the user is responsible for ensuring that these components do not adversely affect or disable safety functions.

NOTICE

If the internal cabinet temperature of the robot controller differs greatly from the ambient temperature, condensation can form, which may cause damage to the electrical components. Do not put the robot controller into operation until the internal temperature of the cabinet has adjusted to the ambient temperature.

Function test

The following tests must be carried out before start-up and recommissioning: It must be ensured that:

- The industrial robot is correctly installed and fastened in accordance with the specifications in the documentation.
- There are no foreign bodies or loose parts on the industrial robot.
- All required safety equipment is correctly installed and operational.
- The power supply ratings of the industrial robot correspond to the local supply voltage and mains type.
- The ground conductor and the equipotential bonding cable are sufficiently rated and correctly connected.
- The connecting cables are correctly connected and the connectors are locked.

Machine data

It must be ensured that the rating plate on the robot controller has the same machine data as those entered in the declaration of incorporation. The machine data on the rating plate of the manipulator and the external axes (optional) must be entered during start-up.



WARNING The industrial robot must not be moved if incorrect machine data are loaded. Death, severe injuries or considerable damage to property may otherwise result. The correct machine data must be loaded.

5.5.4 Manual mode

Manual mode is the mode for setup work. Setup work is all the tasks that have to be carried out on the industrial robot to enable automatic operation. Setup work includes:

- Jog mode
- Teach
- Programming
- Program verification

The following must be taken into consideration in manual mode:

- If the drives are not required, they must be switched off to prevent the manipulator or the external axes (optional) from being moved unintentionally. New or modified programs must always be tested first in Manual Reduced Velocity mode (T1).
- The manipulator, tooling or external axes (optional) must never touch or project beyond the safety fence.
- Workpieces, tooling and other objects must not become jammed as a result of the industrial robot motion, nor must they lead to short-circuits or be liable to fall off.
- All setup work must be carried out, where possible, from outside the safeguarded area.

If the setup work has to be carried out inside the safeguarded area, the following must be taken into consideration:

In **Manual Reduced Velocity mode (T1)**:

- If it can be avoided, there must be no other persons inside the safeguarded area.
If it is necessary for there to be several persons inside the safeguarded area, the following must be observed:
 - Each person must have an enabling device.
 - All persons must have an unimpeded view of the industrial robot.
 - Eye-contact between all persons must be possible at all times.
- The operator must be so positioned that he can see into the danger area and get out of harm's way.

In **Manual High Velocity mode (T2)**:

- This mode may only be used if the application requires a test at a velocity higher than Manual Reduced Velocity.
- Teaching and programming are not permissible in this operating mode.
- Before commencing the test, the operator must ensure that the enabling devices are operational.
- The operator must be positioned outside the danger zone.
- There must be no other persons inside the safeguarded area. It is the responsibility of the operator to ensure this.

5.5.5 Automatic mode

Automatic mode is only permissible in compliance with the following safety measures:

- All safety equipment and safeguards are present and operational.
- There are no persons in the system.
- The defined working procedures are adhered to.

If the manipulator or an external axis (optional) comes to a standstill for no apparent reason, the danger zone must not be entered until an EMERGENCY STOP has been triggered.

5.5.6 Maintenance and repair

After maintenance and repair work, checks must be carried out to ensure the required safety level. The valid national or regional work safety regulations must be observed for this check. The correct functioning of all safety functions must also be tested.

The purpose of maintenance and repair work is to ensure that the system is kept operational or, in the event of a fault, to return the system to an operational state. Repair work includes troubleshooting in addition to the actual repair itself.

The following safety measures must be carried out when working on the industrial robot:

- Carry out work outside the danger zone. If work inside the danger zone is necessary, the user must define additional safety measures to ensure the safe protection of personnel.
- Switch off the industrial robot and secure it (e.g. with a padlock) to prevent it from being switched on again. If it is necessary to carry out work with the robot controller switched on, the user must define additional safety measures to ensure the safe protection of personnel.
- If it is necessary to carry out work with the robot controller switched on, this may only be done in operating mode T1.
- Label the system with a sign indicating that work is in progress. This sign must remain in place, even during temporary interruptions to the work.
- The EMERGENCY STOP systems must remain active. If safety functions or safeguards are deactivated during maintenance or repair work, they must be reactivated immediately after the work is completed.



WARNING Before work is commenced on live parts of the robot system, the main switch must be turned off and secured against being switched on again by unauthorized personnel. The incoming power cable must be deenergized. The robot controller and mains supply lead must then be checked to ensure that it is deenergized. If the KR C4 or VKR C4 robot controller is used: It is not sufficient, before commencing work on live parts, to execute an EMERGENCY STOP or a safety stop, or to switch off the drives, as this does not disconnect the robot system from the mains power supply in the case of the drives of the new generation. Parts remain energized. Death or severe injuries may result.

Faulty components must be replaced using new components with the same article numbers or equivalent components approved by KUKA Roboter GmbH for this purpose.

Cleaning and preventive maintenance work is to be carried out in accordance with the operating instructions.

Robot controller

Even when the robot controller is switched off, parts connected to peripheral devices may still carry voltage. The external power sources must therefore be switched off if work is to be carried out on the robot controller.

The ESD regulations must be adhered to when working on components in the robot controller.

Voltages in excess of 50 V (up to 600 V) can be present in various components for several minutes after the robot controller has been switched off! To prevent

life-threatening injuries, no work may be carried out on the industrial robot in this time.

Water and dust must be prevented from entering the robot controller.

Counterbalancing system

Some robot variants are equipped with a hydropneumatic, spring or gas cylinder counterbalancing system.

The hydropneumatic and gas cylinder counterbalancing systems are pressure equipment and, as such, are subject to obligatory equipment monitoring. Depending on the robot variant, the counterbalancing systems correspond to category 0, II or III, fluid group 2, of the Pressure Equipment Directive.

The user must comply with the applicable national laws, regulations and standards pertaining to pressure equipment.

Inspection intervals in Germany in accordance with Industrial Safety Order, Sections 14 and 15. Inspection by the user before commissioning at the installation site.

The following safety measures must be carried out when working on the counterbalancing system:

- The manipulator assemblies supported by the counterbalancing systems must be secured.
- Work on the counterbalancing systems must only be carried out by qualified personnel.

Hazardous substances

The following safety measures must be carried out when handling hazardous substances:

- Avoid prolonged and repeated intensive contact with the skin.
- Avoid breathing in oil spray or vapors.
- Clean skin and apply skin cream.



To ensure safe use of our products, we recommend that our customers regularly request up-to-date safety data sheets from the manufacturers of hazardous substances.

5.5.7 Decommissioning, storage and disposal

The industrial robot must be decommissioned, stored and disposed of in accordance with the applicable national laws, regulations and standards.

5.6 Applied norms and regulations

Name	Definition	Edition
2006/42/EC	Machinery Directive: Directive 2006/42/EC of the European Parliament and of the Council of 17 May 2006 on machinery, and amending Directive 95/16/EC (recast)	2006
2004/108/EC	EMC Directive: Directive 2004/108/EC of the European Parliament and of the Council of 15 December 2004 on the approximation of the laws of the Member States relating to electromagnetic compatibility and repealing Directive 89/336/EEC	2004

Name	Definition	Edition
97/23/EC	Pressure Equipment Directive: Directive 97/23/EC of the European Parliament and of the Council of 29 May 1997 on the approximation of the laws of the Member States concerning pressure equipment (Only applicable for robots with hydropneumatic counter-balancing system.)	1997
EN ISO 13850	Safety of machinery: Emergency stop - Principles for design	2008
EN ISO 13849-1	Safety of machinery: Safety-related parts of control systems - Part 1: General principles of design	2008
EN ISO 13849-2	Safety of machinery: Safety-related parts of control systems - Part 2: Validation	2008
EN ISO 12100	Safety of machinery: General principles of design, risk assessment and risk reduction	2010
EN ISO 10218-1	Industrial robots: Safety	2011
EN 614-1	Safety of machinery: Ergonomic design principles - Part 1: Terms and general principles	2006
EN 61000-6-2	Electromagnetic compatibility (EMC): Part 6-2: Generic standards; Immunity for industrial environments	2005
EN 61000-6-4	Electromagnetic compatibility (EMC): Part 6-4: Generic standards; Emission standard for industrial environments	2007
EN 60204-1	Safety of machinery: Electrical equipment of machines - Part 1: General requirements	2006

6 Planning

6.1 Mounting base with centering

Description The mounting base with centering is used when the robot is fastened to the floor.

The mounting base with centering consists of:

- Bedplate
- Chemical anchors (resin-bonded anchors)
- Fasteners

This mounting variant requires a level and smooth surface on a concrete foundation with adequate load bearing capacity. The concrete foundation must be able to accommodate the forces occurring during operation. There must be no layers of insulation or screed between the bedplate and the concrete foundation.

The minimum dimensions must be observed.

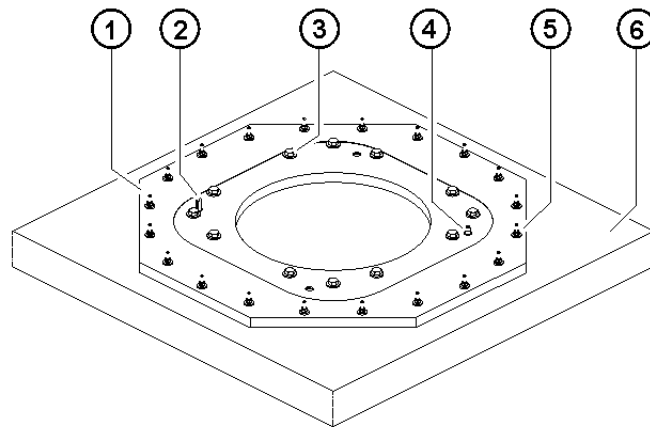

Fig. 6-1: Fastening to mounting base

- | | |
|----------------|---|
| 1 Bedplate | 4 Pin |
| 2 Sword pin | 5 Chemical anchor (resin-bonded anchor) |
| 3 Hexagon bolt | 6 Concrete foundation |

Grade of concrete for foundations When producing foundations from concrete, observe the load-bearing capacity of the ground and the country-specific construction regulations. There must be no layers of insulation or screed between the bedplates and the concrete foundation. The quality of the concrete must meet the requirements of the following standard:

- C20/25 according to DIN EN 206-1:2001/DIN 1045-2:2008

Dimensioned drawing The following illustration (>>> Fig. 6-2) provides all the necessary information on the mounting base, together with the required foundation data.

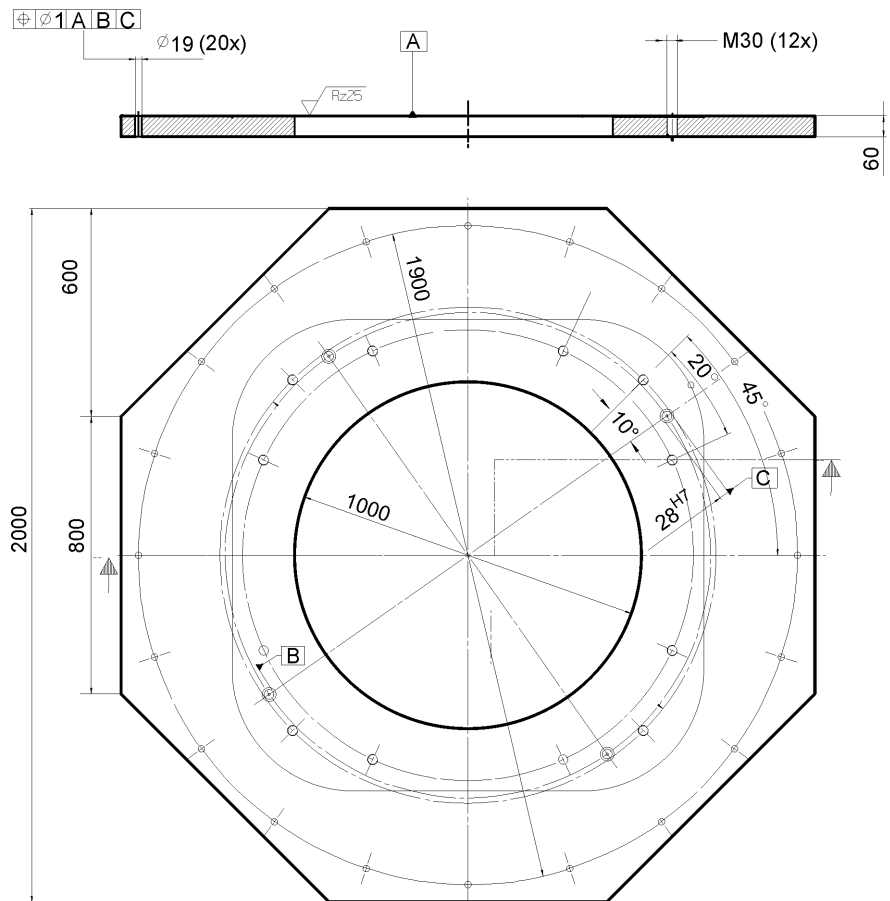

Fig. 6-2: Mounting base with centering, dimensioned drawing

To ensure that the anchor forces are safely transmitted to the foundation, observe the dimensions for concrete foundations specified in the following illustration (>>> Fig. 6-3).

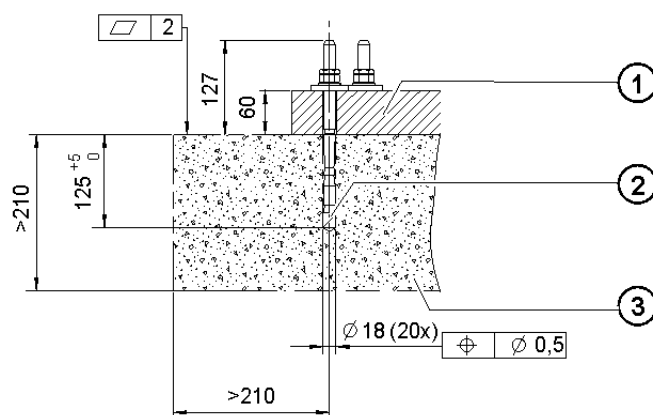

Fig. 6-3: Cross-section of foundations

- 1 Bedplate
- 2 Chemical anchor (resin-bonded anchor)
- 3 Concrete foundation

6.2 Machine frame mounting

Description

The machine frame mounting assembly is used when the robot is fastened on a steel structure, a booster frame (pedestal) or a KUKA linear unit. It must be ensured that the substructure is able to withstand safely the forces occurring during operation (foundation loads). The following diagram contains all the necessary information that must be observed when preparing the mounting surface.

The machine frame mounting assembly consists of:

- Pin with fasteners (>>> Fig. 6-4)
- Sword pin with fasteners
- Hexagon bolts with conical spring washers

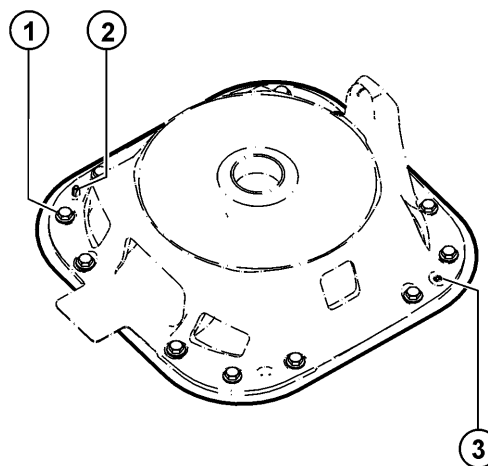

Fig. 6-4: Machine frame mounting

- | | |
|----------------------|-------|
| 1 Hexagon bolts, 12x | 3 Pin |
| 2 Sword pin | |

Dimensioned drawing

The following illustration (>>> Fig. 6-2) provides all the necessary information on the mounting base, together with the required foundation data.

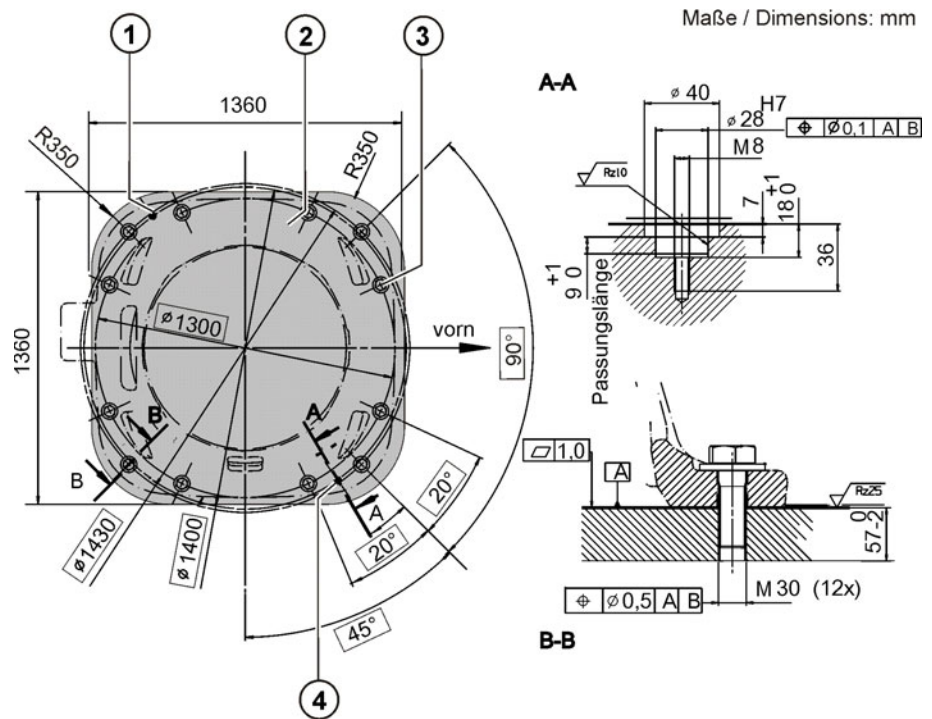

Fig. 6-5: Machine frame mounting, dimensioned drawing

- | | | | |
|---|----------------------------|---|--------------------|
| 1 | Sword pin | 3 | Hexagon bolts, 12x |
| 2 | Mounting surface, machined | 4 | Pin |

6.3 Connecting cables and interfaces

Description

The connecting cables comprise all the cables for transferring energy and signals between the robot and the robot controller. Depending on the specification of the robot, the following connecting cables are used:

- Standard connecting cables
- Connecting cables for RoboTeam robots
- Connecting cables for SafeRobot

Depending on the specification of the robot, various connecting cables are used. Cable lengths of 7 m, 15 m, 25 m, 35 m and 50 m are available. The maximum length of the connecting cables must not exceed 50 m. Thus if the robot is operated on a linear unit which has its own energy supply chain these cables must also be taken into account.

If the length of the connecting cables is greater than 35 m, a separate ground conductor must be connected between the robot and the control cabinet. An additional ground conductor is always required to provide a low-resistance connection between the robot and the control cabinet in accordance with DIN EN 60204. The ground conductors are connected via ring cable lugs. The threaded bolt for connecting the ground conductor is located on the base frame of the robot.

If the robot is equipped with remote junction boxes, the permissible lengths of the connecting cables are limited to 35 m. The cables of the remote RDC box (cable set) must be routed in the same way as the connecting cables.

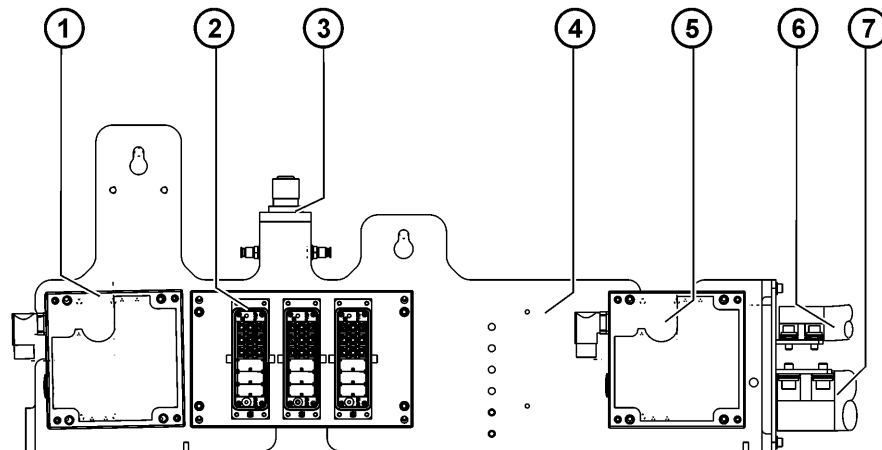

Fig. 6-6: Junction boxes, remote

- | | |
|----------------------|------------------|
| 1 RDC2 box | 5 RDC2 box |
| 2 Motor junction box | 6 Control cables |
| 3 Pressure regulator | 7 Motor cables |
| 4 Connection plate | |

The following points must be observed when planning and routing the connecting cables:

- The bending radius for fixed routing must not be less than 150 mm for motor cables and 60 mm for control cables.
- Protect cables against exposure to mechanical stress.
- Route the cables without mechanical stress – no tensile forces on the connectors
- Cables are only to be installed indoors.
- Observe permissible temperature range (fixed installation) of 263 K (-10 °C) to 343 K (+70 °C).
- Route the motor cables and the data cables separately in metal ducts; if necessary, additional measures must be taken to ensure electromagnetic compatibility (EMC).

Interface for energy supply system

The robot can be equipped with an energy supply system between axis 1 and axis 3 and a second energy supply system between axis 3 and axis 6. The A1 interface required for this is located on the rear, the A3 interface is located on the side of the arm and the interface for axis 6 is located on the robot tool. The interfaces are equipped with connections for cables and hoses depending on the application. Detailed information on the connector pin allocation, threaded unions, etc. is given in separate documentation.

7 Transportation

7.1 Transporting the robot

Before transporting the robot, always move the robot into its transport position (>>> Fig. 7-1). It must be ensured that the robot is stable while it is being transported. The robot must remain in its transport position until it has been fastened in position. Before the robot is lifted, it must be ensured that it is free from obstructions. Remove all transport safeguards, such as nails and screws, in advance. First remove any rust or glue on contact surfaces.

Transport position

The robot must be in the transport position (>>> Fig. 7-1) before it can be transported. The robot is in the transport position when the axes are in the following positions:

Axis	A 1	A 2	A 3	A 4	A 5	A 6
Angle ¹⁾	0°	-130°	+130°	0°	+90°	0°
Angle ²⁾	0°	-140°	+140°	0°	+90°	0°

¹⁾ Robot with buffer installed on axis 2

²⁾ Robot without buffer on 2

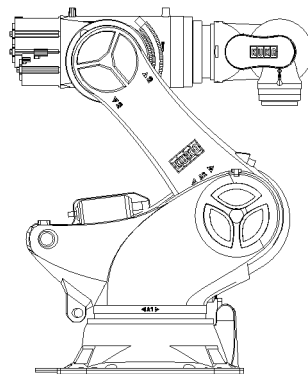

Fig. 7-1: Transport position

Transport dimensions

The transport dimensions (>>> Fig. 7-2) and (>>> Fig. 7-3) for the robot can be noted from the following diagrams. The position of the center of gravity and the weight vary according to the specific configuration and the position of axis 2. The specified dimensions refer to the robot without equipment.

The dimensions with the index ¹⁾ apply for normal transportation. The dimensions with the index ²⁾ are obtained if the buffer on the minus side of axis 2 is removed.

Maße / Dimensions: mm

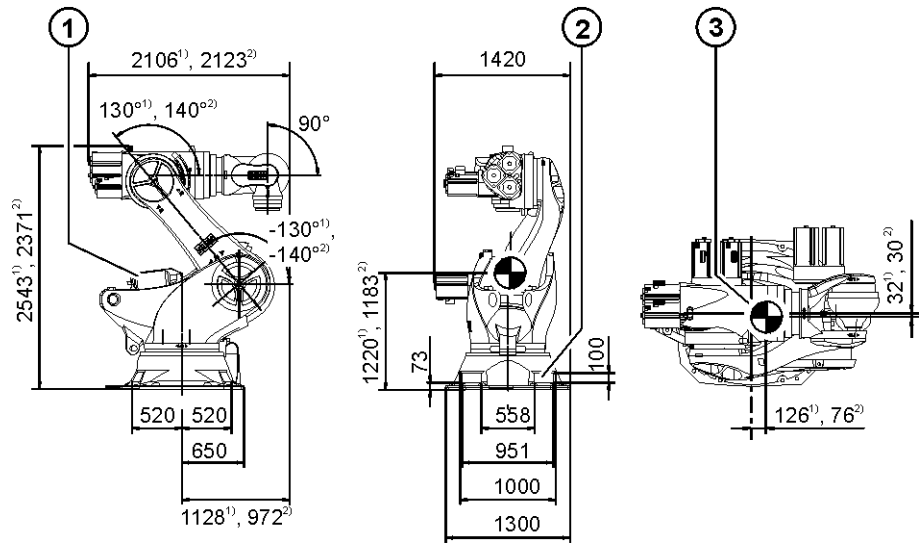

Fig. 7-2: Transport dimensions with in-line wrist IW 1000

- 1 Robot
- 2 Fork slots
- 3 Center of gravity

Maße / Dimensions: mm

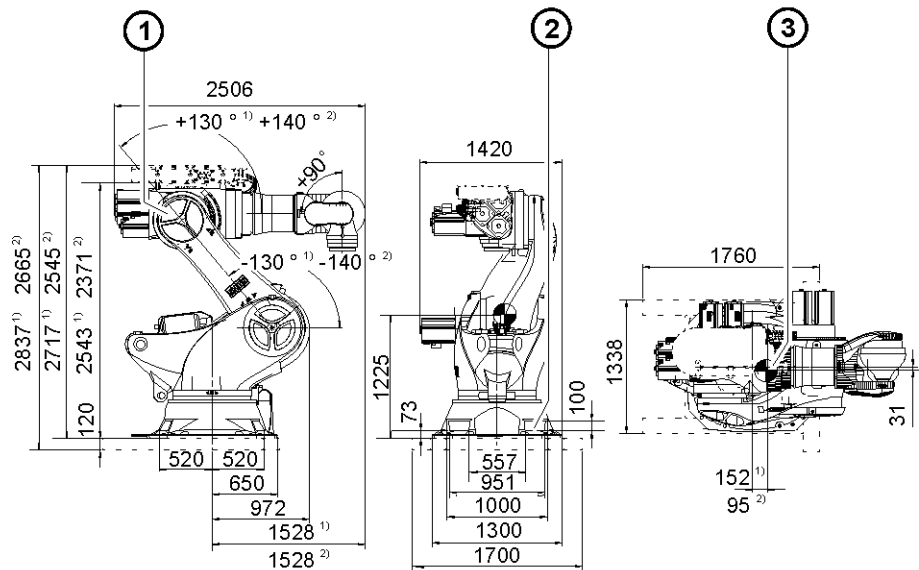

Fig. 7-3: Transport dimensions with in-line wrist IW 750

- 1 Robot
- 2 Fork slots
- 3 Center of gravity

Transportation

The robot can be transported by fork lift truck or using lifting tackle.

⚠ WARNING Use of unsuitable handling equipment may result in damage to the robot or injury to persons. Only use authorized handling equipment with a sufficient load-bearing capacity. Only transport the robot in the manner specified here.

Transportation by fork lift truck

For transport by fork lift truck (>>> Fig. 7-4), cast fork slots are provided in the base frame. The fork lift truck must have a minimum payload capacity of 6 t.

NOTICE Avoid excessive loading of the fork slots through undue inward or outward movement of hydraulically adjustable forks of the fork lift truck. Failure to do so may result in material damage.

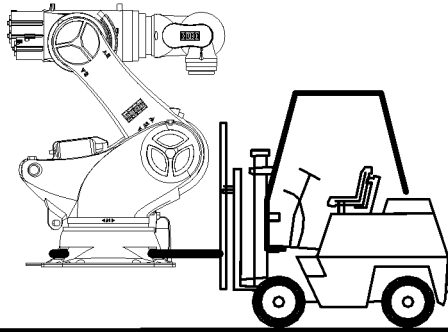

Fig. 7-4: Transport by fork lift truck

Transportation using lifting tackle

The robot can also be transported using lifting tackle (>>> Fig. 7-5) (1). The robot must be in the transport position. The lifting tackle is attached to 3 eye-bolts (2) that are permanently screwed into the rotating column (3). All ropes must be long enough and must be routed in such a way that the robot is not damaged. Installed tools and pieces of equipment can cause undesirable shifts in the center of gravity.

⚠ WARNING The robot may tip during transportation. Risk of personal injury and damage to property. If the robot is being transported using lifting tackle, special care must be exercised to prevent it from tipping. Additional safeguarding measures must be taken. It is forbidden to pick up the robot in any other way using a crane!

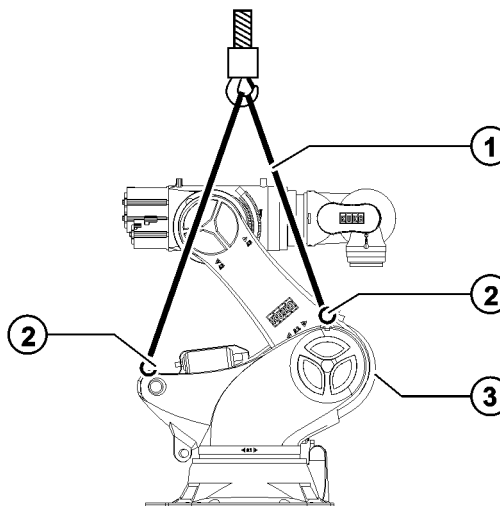

Fig. 7-5: Lifting tackle

- 1 Lifting tackle
- 2 Eyebolt
- 3 Rotating column

Transportation with transport frame

If the permitted height for transportation is exceeded in the transport position, the robot can be moved into a different position. To do this, the robot must be secured to the transport frame with all holding-down bolts. Once this has been done, axes 2 and 3 can be moved so as to reduce the overall height (>>> Fig. 7-6) and (>>> Fig. 7-7). The robot can be transported on the transport frame by crane or fork lift truck (minimum payload capacity 8,000 kg). Both robot variants, with transport frame and without equipment, have an overall weight of approx. 5,600 kg.

Before the robot can be transported on the transport frame, the robot axes must be in the following positions:

Axis	A 1	A 2	A 3	A 4	A 5	A 6
Angle	0°	-16°	+145°	0° +25°*	0° +120°*	-90°
* Angle for in-line wrist IW 750						

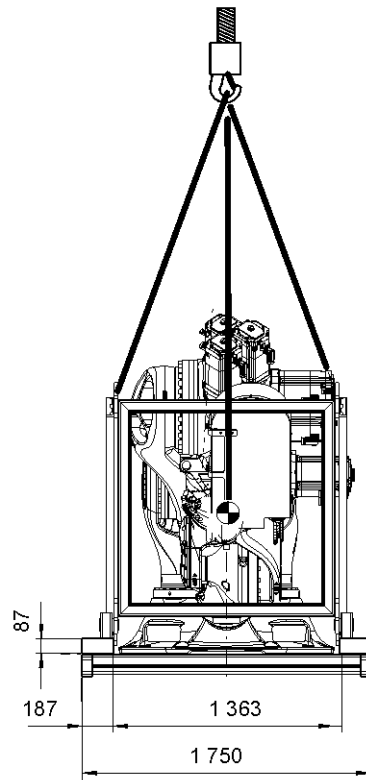
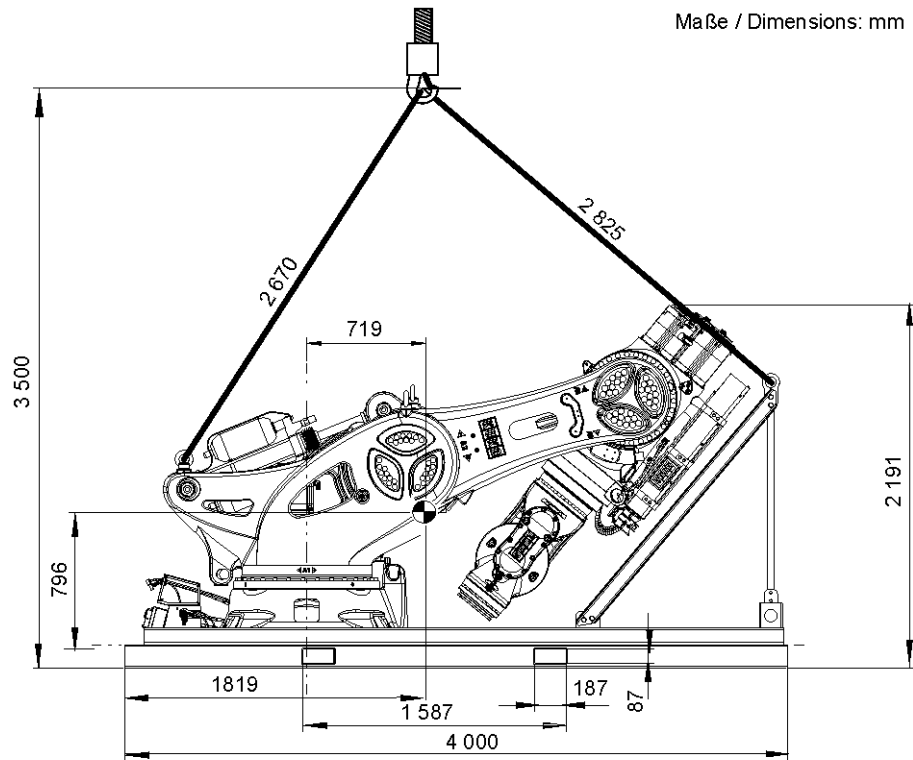

Fig. 7-6: Transport frame for in-line wrist IW 1000

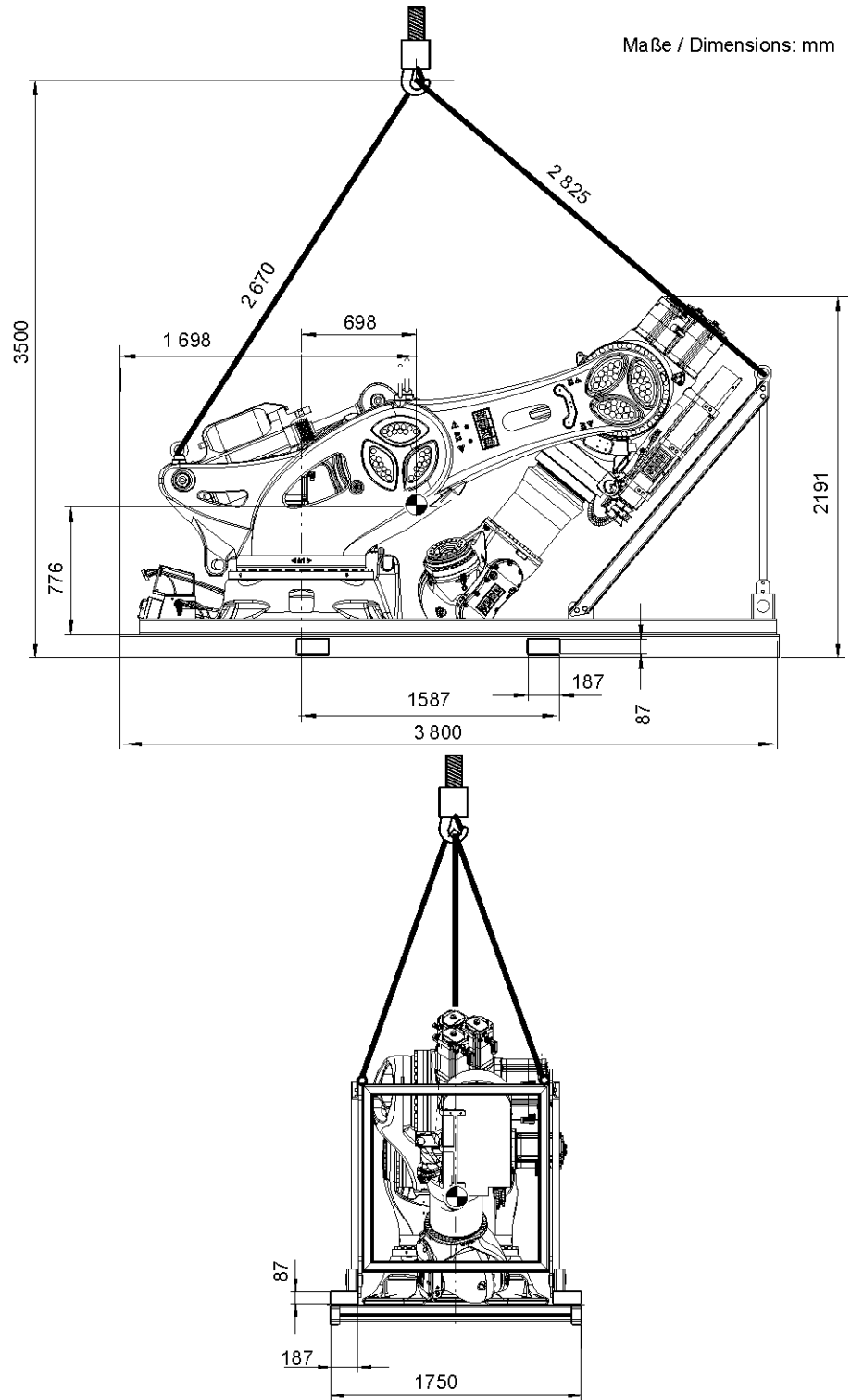

Fig. 7-7: Transport frame for in-line wrist IW 750

8 KUKA Service

8.1 Requesting support

Introduction The KUKA Roboter GmbH documentation offers information on operation and provides assistance with troubleshooting. For further assistance, please contact your local KUKA subsidiary.

Information The following information is required for processing a support request:

- Model and serial number of the robot
- Model and serial number of the controller
- Model and serial number of the linear unit (if applicable)
- Model and serial number of the energy supply system (if applicable)
- Version of the KUKA System Software
- Optional software or modifications
- Archive of the software

For KUKA System Software V8: instead of a conventional archive, generate the special data package for fault analysis (via **KrcDiag**).
- Application used
- Any external axes used
- Description of the problem, duration and frequency of the fault

8.2 KUKA Customer Support

Availability KUKA Customer Support is available in many countries. Please do not hesitate to contact us if you have any questions.

Argentina Ruben Costantini S.A. (Agency)
Luis Angel Huergo 13 20
Parque Industrial
2400 San Francisco (CBA)
Argentina
Tel. +54 3564 421033
Fax +54 3564 428877
ventas@costantini-sa.com

Australia Headland Machinery Pty. Ltd.
Victoria (Head Office & Showroom)
95 Highbury Road
Burwood
Victoria 31 25
Australia
Tel. +61 3 9244-3500
Fax +61 3 9244-3501
vic@headland.com.au
www.headland.com.au

Belgium	KUKA Automatisering + Robots N.V. Centrum Zuid 1031 3530 Houthalen Belgium Tel. +32 11 516160 Fax +32 11 526794 info@kuka.be www.kuka.be
Brazil	KUKA Roboter do Brasil Ltda. Travessa Claudio Armando, nº 171 Bloco 5 - Galpões 51/52 Bairro Assunção CEP 09861-7630 São Bernardo do Campo - SP Brazil Tel. +55 11 4942-8299 Fax +55 11 2201-7883 info@kuka-roboter.com.br www.kuka-roboter.com.br
Chile	Robotec S.A. (Agency) Santiago de Chile Chile Tel. +56 2 331-5951 Fax +56 2 331-5952 robotec@robotec.cl www.robotec.cl
China	KUKA Robotics China Co.,Ltd. Songjiang Industrial Zone No. 388 Minshen Road 201612 Shanghai China Tel. +86 21 6787-1888 Fax +86 21 6787-1803 www.kuka-robotics.cn
Germany	KUKA Roboter GmbH Zugspitzstr. 140 86165 Augsburg Germany Tel. +49 821 797-4000 Fax +49 821 797-1616 info@kuka-roboter.de www.kuka-roboter.de

France KUKA Automatismes + Robotique SAS
Techvallée
6, Avenue du Parc
91140 Villebon S/Yvette
France
Tel. +33 1 6931660-0
Fax +33 1 6931660-1
commercial@kuka.fr
www.kuka.fr

India KUKA Robotics India Pvt. Ltd.
Office Number-7, German Centre,
Level 12, Building No. - 9B
DLF Cyber City Phase III
122 002 Gurgaon
Haryana
India
Tel. +91 124 4635774
Fax +91 124 4635773
info@kuka.in
www.kuka.in

Italy KUKA Roboter Italia S.p.A.
Via Pavia 9/a - int.6
10098 Rivoli (TO)
Italy
Tel. +39 011 959-5013
Fax +39 011 959-5141
kuka@kuka.it
www.kuka.it

Japan KUKA Robotics Japan K.K.
YBP Technical Center
134 Godo-cho, Hodogaya-ku
Yokohama, Kanagawa
240 0005
Japan
Tel. +81 45 744 7691
Fax +81 45 744 7696
info@kuka.co.jp

Canada KUKA Robotics Canada Ltd.
6710 Maritz Drive - Unit 4
Mississauga
L5W 0A1
Ontario
Canada
Tel. +1 905 670-8600
Fax +1 905 670-8604
info@kukarobotics.com
www.kuka-robotics.com/canada

Korea	KUKA Robotics Korea Co. Ltd. RIT Center 306, Gyeonggi Technopark 1271-11 Sa 3-dong, Sangnok-gu Ansan City, Gyeonggi Do 426-901 Korea Tel. +82 31 501-1451 Fax +82 31 501-1461 info@kukakorea.com
Malaysia	KUKA Robot Automation Sdn Bhd South East Asia Regional Office No. 24, Jalan TPP 1/10 Taman Industri Puchong 47100 Puchong Selangor Malaysia Tel. +60 3 8061-0613 or -0614 Fax +60 3 8061-7386 info@kuka.com.my
Mexico	KUKA de México S. de R.L. de C.V. Progreso #8 Col. Centro Industrial Puente de Vigas Tlalnepantla de Baz 54020 Estado de México Mexico Tel. +52 55 5203-8407 Fax +52 55 5203-8148 info@kuka.com.mx www.kuka-robotics.com/mexico
Norway	KUKA Sveiseanlegg + Roboter Sentrumsvegen 5 2867 Hov Norway Tel. +47 61 18 91 30 Fax +47 61 18 62 00 info@kuka.no
Austria	KUKA Roboter Austria GmbH Vertriebsbüro Österreich Regensburger Strasse 9/1 4020 Linz Austria Tel. +43 732 784752 Fax +43 732 793880 office@kuka-roboter.at www.kuka-roboter.at

Poland KUKA Roboter Austria GmbH
Spółka z ograniczoną odpowiedzialnością
Oddział w Polsce
Ul. Porcelanowa 10
40-246 Katowice
Poland
Tel. +48 327 30 32 13 or -14
Fax +48 327 30 32 26
ServicePL@kuka-roboter.de

Portugal KUKA Sistemas de Automatización S.A.
Rua do Alto da Guerra n° 50
Armazém 04
2910 011 Setúbal
Portugal
Tel. +351 265 729780
Fax +351 265 729782
kuka@mail.telepac.pt

Russia OOO KUKA Robotics Rus
Webnaja ul. 8A
107143 Moskau
Russia
Tel. +7 495 781-31-20
Fax +7 495 781-31-19
kuka-robotics.ru

Sweden KUKA Svetsanläggningar + Robotar AB
A. Odhners gata 15
421 30 Västra Frölunda
Sweden
Tel. +46 31 7266-200
Fax +46 31 7266-201
info@kuka.se

Switzerland KUKA Roboter Schweiz AG
Industriestr. 9
5432 Neuenhof
Switzerland
Tel. +41 44 74490-90
Fax +41 44 74490-91
info@kuka-roboter.ch
www.kuka-roboter.ch

Spain	KUKA Robots IBÉRICA, S.A. Pol. Industrial Torrent de la Pastera Carrer del Bages s/n 08800 Vilanova i la Geltrú (Barcelona) Spain Tel. +34 93 8142-353 Fax +34 93 8142-950 Comercial@kuka-e.com www.kuka-e.com
South Africa	Jendamark Automation LTD (Agency) 76a York Road North End 6000 Port Elizabeth South Africa Tel. +27 41 391 4700 Fax +27 41 373 3869 www.jendamark.co.za
Taiwan	KUKA Robot Automation Taiwan Co., Ltd. No. 249 Pujong Road Jungli City, Taoyuan County 320 Taiwan, R. O. C. Tel. +886 3 4331988 Fax +886 3 4331948 info@kuka.com.tw www.kuka.com.tw
Thailand	KUKA Robot Automation (M)SdnBhd Thailand Office c/o Maccall System Co. Ltd. 49/9-10 Soi Kingkaew 30 Kingkaew Road Tt. Rachatheva, A. Bangpli Samutprakarn 10540 Thailand Tel. +66 2 7502737 Fax +66 2 6612355 atika@ji-net.com www.kuka-roboter.de
Czech Republic	KUKA Roboter Austria GmbH Organisation Tschechien und Slowakei Sezemická 2757/2 193 00 Praha Horní Počernice Czech Republic Tel. +420 22 62 12 27 2 Fax +420 22 62 12 27 0 support@kuka.cz

Hungary KUKA Robotics Hungaria Kft.
Fő út 140
2335 Taksony
Hungary
Tel. +36 24 501609
Fax +36 24 477031
info@kuka-robotics.hu

USA KUKA Robotics Corporation
51870 Shelby Parkway
Shelby Township
48315-1787
Michigan
USA
Tel. +1 866 873-5852
Fax +1 866 329-5852
info@kukarobotics.com
www.kukarobotics.com

UK KUKA Automation + Robotics
Hereward Rise
Halesowen
B62 8AN
UK
Tel. +44 121 585-0800
Fax +44 121 585-0900
sales@kuka.co.uk

Index

Numbers

2004/108/EC 53
 2006/42/EC 53
 89/336/EEC 53
 95/16/EC 53
 97/23/EC 54

A

Accessories 9, 41
 Ambient temperature, operation 14, 16
 Ambient temperature, operation, Safe RDC 14, 16
 Ambient temperature, start-up 14, 16
 Ambient temperature, storage 14, 16
 Ambient temperature, transportation 14, 16
 Angle of rotation 28
 Applied norms and regulations 53
 Arm 9, 10
 Automatic mode 51
 Axis data 17
 Axis range 43
 Axis range limitation 46
 Axis range monitoring 47

B

Base frame 9, 11
 Basic data 13, 15
 Brake defect 48
 Brake release device 47
 Braking distance 43

C

CE mark 42
 Center of gravity 61
 Cleaning work 52
 Connecting cables 9, 14, 16, 41, 58
 Counterbalancing system 9, 11, 53

D

Danger zone 43
 Declaration of conformity 42
 Declaration of incorporation 41, 42
 Decommissioning 53
 Dimensions, transport 61
 Disposal 53
 Documentation, industrial robot 5

E

EC declaration of conformity 42
 Electrical installations 9
 EMC Directive 42, 53
 EN 60204-1 54
 EN 61000-6-2 54
 EN 61000-6-4 54
 EN 614-1 54
 EN ISO 10218-1 54
 EN ISO 12100 54
 EN ISO 13849-1 54

EN ISO 13849-2 54
 EN ISO 13850 54
 Extension 28
 External axes 41, 43

F

Faults 49
 Fork lift truck 62
 Foundry robots 13, 15
 Foundry, equipment 13, 15
 Function test 50

G

Gear unit temperatures 14, 16
 General information 27
 General safety measures 48

H

Handling equipment 63
 Hazardous substances 53
 Humidity rating 14, 16
 Hydropneumatic 11

I

In-line wrist 9, 10
 In-line wrist, F variant 10
 Industrial robot 9, 41
 Intended use 42
 Interfaces 58
 Introduction 5

K

KCP 43, 48
 KCP, KUKA Control Panel 28
 Keyboard, external 49
 KUKA Customer Support 67
 KUKA smartPAD 43

L

Labeling 48
 Liability 41
 Lifting tackle 62, 63
 Linear unit 41
 Link arm 9, 11
 Loads acting on the mounting base 25
 Low Voltage Directive 42

M

Machine data 50
 Machine frame mounting 57
 Machinery Directive 42, 53
 main axes 28
 Maintenance 52
 Manipulator 9, 41, 43, 46
 Manual mode 51
 Mechanical axis range limitation 46
 Mechanical end stops 46
 Mounting base with centering 55

Mounting flange 10, 21, 23
Mouse, external 49

O

Operator 43, 44
Options 9, 41
Overload 48
Overview of the industrial robot 9

P

Palletizing mode 10
Payload diagram 20, 23
Payloads 20, 22
Personnel 44
Pin 57
Plant integrator 43
Plates and labels 26
Positioner 41
Pressure Equipment Directive 53, 54
Pressure regulator 13, 15
Preventive maintenance work 52
Principal components 9
Product description 9
Program override, motion velocity 28
Protective equipment, overview 46
Purpose 7

R

Reaction distance 43
Recommissioning 50
Relative air humidity 14, 16
Release device 47
Repair 52
Robot controller 9, 41
Rotating column 9, 11

S

Safety 41
Safety instructions 5
Safety zone 43, 45, 46
Safety, general 41
Service life 43
Service, KUKA Roboter 67
smartPAD 43
Software 9, 41
Start-up 50
STOP 0 28, 43
STOP 1 28, 43
STOP 2 43
Stop category 0 43
Stop category 1 43
Stop category 2 43
Stop signal 27
Stopping distance 27, 43, 46
Stopping distances 27, 34
Stopping distances, KR 1000 1300 titan PA 29
Stopping time 27
Stopping times 27, 34
Stopping times, KR 1000 1300 titan PA 29
Storage 53
Supplementary load 21, 24

Support request 67
Sword pin 57
System integrator 42, 43, 44

T

T1 43
T2 43
Teach pendant 9, 41
Technical data 13
Terms used 28
Terms used, safety 43
Training 7
Transport dimensions 13, 15
Transport frame 13, 15, 64
Transport position 61
Transportation 49, 61
Turn-tilt table 41

U

Use, contrary to intended use 41
Use, improper 41
User 43, 44
Users 7

W

Warnings 5
Working envelope 18
Working range limitation 46
Workspace 43, 45, 46

