

KR AGILUS sixx

With W and C Variants
Specification

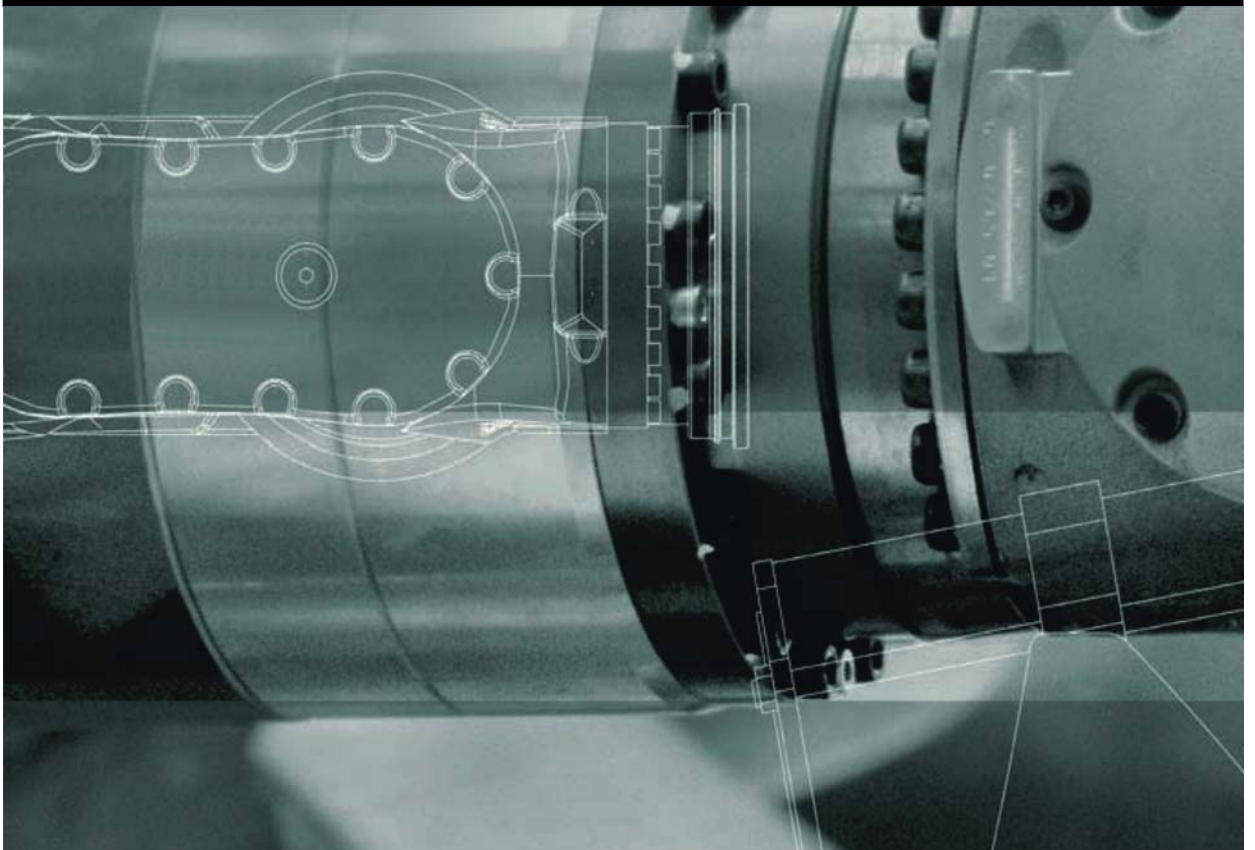

Issued: 22.07.2013

Version: Spez KR AGILUS sixx V8 en (PDF)



© Copyright 2013

KUKA Roboter GmbH
Zugspitzstraße 140
D-86165 Augsburg
Germany

This documentation or excerpts therefrom may not be reproduced or disclosed to third parties without the express permission of KUKA Roboter GmbH.

Other functions not described in this documentation may be operable in the controller. The user has no claims to these functions, however, in the case of a replacement or service work.

We have checked the content of this documentation for conformity with the hardware and software described. Nevertheless, discrepancies cannot be precluded, for which reason we are not able to guarantee total conformity. The information in this documentation is checked on a regular basis, however, and necessary corrections will be incorporated in the subsequent edition.

Subject to technical alterations without an effect on the function.

Translation of the original documentation

KIM-PS5-DOC

Publication:	Pub Spez KR AGILUS sixx (PDF) en
Book structure:	Spez KR AGILUS sixx V6.1
Version:	Spez KR AGILUS sixx V8 en (PDF)

Contents

1	Introduction	5
1.1	Industrial robot documentation	5
1.2	Representation of warnings and notes	5
1.3	Terms used	5
2	Purpose	7
2.1	Target group	7
2.2	Intended use	7
3	Product description	9
3.1	Overview of the robot system	9
3.2	Description of the manipulator	10
4	Technical data	13
4.1	Basic data, KR 6 sixx	14
4.2	Axis data, KR 6 sixx	16
4.3	Payloads, KR 6 sixx	24
4.4	Mounting base data, KR 6 sixx	29
4.5	Basic data, KR 10 sixx	30
4.6	Axis data, KR 10 sixx	32
4.7	Payloads, KR 10 sixx	41
4.8	Mounting base data, KR 10 sixx	47
4.9	Plates and labels	48
4.10	Stopping distances and times	49
4.10.1	General information	49
4.10.2	Terms used	50
4.10.3	Stopping distances and times, KR 6 R700 sixx and KR 6 R700 sixx C	51
4.10.3.1	Stopping distances and stopping times for STOP 0, axis 1 to axis 3	51
4.10.3.2	Stopping distances and stopping times for STOP 1, axis 1	52
4.10.3.3	Stopping distances and stopping times for STOP 1, axis 2	54
4.10.3.4	Stopping distances and stopping times for STOP 1, axis 3	56
4.10.4	Stopping distances and times, KR 6 R700 sixx W	56
4.10.4.1	Stopping distances and stopping times for STOP 0, axis 1 to axis 3	56
4.10.4.2	Stopping distances and stopping times for STOP 1, axis 1	58
4.10.4.3	Stopping distances and stopping times for STOP 1, axis 2	60
4.10.4.4	Stopping distances and stopping times for STOP 1, axis 2	62
4.10.5	Stopping distances and times, KR 6 R900 sixx	62
4.10.5.1	Stopping distances and stopping times for STOP 0, axis 1 to axis 3	62
4.10.5.2	Stopping distances and stopping times for STOP 1, axis 1	64
4.10.5.3	Stopping distances and stopping times for STOP 1, axis 2	66
4.10.5.4	Stopping distances and stopping times for STOP 1, axis 3	68
4.10.6	Stopping distances and times, KR 6 R900 sixx W	68
4.10.6.1	Stopping distances and stopping times for STOP 0, axis 1 to axis 3	68
4.10.6.2	Stopping distances and stopping times for STOP 1, axis 1	70
4.10.6.3	Stopping distances and stopping times for STOP 1, axis 2	72
4.10.6.4	Stopping distances and stopping times for STOP 1, axis 3	74
4.10.7	Stopping distances and times, KR 10 R900 sixx and KR 10 R1100 sixx	74
4.10.7.1	Stopping distances and stopping times for STOP 0, axis 1 to axis 3	74

4.10.7.2	Stopping distances and stopping times for STOP 1, axis 1	76
4.10.7.3	Stopping distances and stopping times for STOP 1, axis 2	78
4.10.7.4	Stopping distances and stopping times for STOP 1, axis 3	80
4.10.8	Stopping distances and times, KR 10 R900 sixx W and KR 10 R1100 sixx W	80
4.10.8.1	Stopping distances and stopping times for STOP 0, axis 1 to axis 3	80
4.10.8.2	Stopping distances and stopping times for STOP 1, axis 1	82
4.10.8.3	Stopping distances and stopping times for STOP 1, axis 2	84
4.10.8.4	Stopping distances and stopping times for STOP 1, axis 3	86
5	Safety	87
5.1	General	87
5.1.1	Liability	87
5.1.2	Intended use of the industrial robot	88
5.1.3	EC declaration of conformity and declaration of incorporation	88
5.1.4	Terms used	89
5.2	Personnel	90
5.3	Workspace, safety zone and danger zone	91
5.4	Overview of protective equipment	92
5.4.1	Mechanical end stops	92
5.4.2	Mechanical axis range limitation (optional)	92
5.4.3	Axis range monitoring (optional)	93
5.4.4	Options for moving the manipulator without drive energy	93
5.4.5	Labeling on the industrial robot	94
5.5	Safety measures	94
5.5.1	General safety measures	94
5.5.2	Transportation	95
5.5.3	Start-up and recommissioning	96
5.5.4	Manual mode	97
5.5.5	Automatic mode	97
5.5.6	Maintenance and repair	98
5.5.7	Decommissioning, storage and disposal	99
5.6	Applied norms and regulations	99
6	Planning	101
6.1	Mounting base	101
6.2	Machine frame mounting	103
6.3	Connecting cables and interfaces	104
6.4	Customer interfaces	105
7	Transportation	111
7.1	Transporting the manipulator	111
8	KUKA Service	117
8.1	Requesting support	117
8.2	KUKA Customer Support	117
	Index	125

1 Introduction

1.1 Industrial robot documentation

The industrial robot documentation consists of the following parts:

- Documentation for the manipulator
- Documentation for the robot controller
- Operating and programming instructions for the KUKA System Software
- Documentation relating to options and accessories
- Parts catalog on storage medium

Each of these sets of instructions is a separate document.

1.2 Representation of warnings and notes

Safety

These warnings are relevant to safety and **must** be observed.

 **DANGER** These warnings mean that it is certain or highly probable that death or severe injuries **will** occur, if no precautions are taken.

 **WARNING** These warnings mean that death or severe injuries **may** occur, if no precautions are taken.

 **CAUTION** These warnings mean that minor injuries **may** occur, if no precautions are taken.

 **NOTICE** These warnings mean that damage to property **may** occur, if no precautions are taken.

 These warnings contain references to safety-relevant information or general safety measures.
These warnings do not refer to individual hazards or individual precautionary measures.

This warning draws attention to procedures which serve to prevent or remedy emergencies or malfunctions:

 **SAFETY INSTRUCTIONS** Procedures marked with this warning **must** be followed exactly.

Notes

These hints serve to make your work easier or contain references to further information.

 Tip to make your work easier or reference to further information.

1.3 Terms used

Term	Description
MEMD	Micro Electronic Mastering Device
KL	KUKA linear unit

Term	Description
RDC	Resolver Digital Converter
smartPAD	The smartPAD teach pendant has all the operator control and display functions required for operating and programming the industrial robot.

2 Purpose

2.1 Target group

This documentation is aimed at users with the following knowledge and skills:

- Advanced knowledge of mechanical engineering
- Advanced knowledge of electrical and electronic systems
- Knowledge of the robot controller system



For optimal use of our products, we recommend that our customers take part in a course of training at KUKA College. Information about the training program can be found at www.kuka.com or can be obtained directly from our subsidiaries.

2.2 Intended use

Use

The industrial robot is intended for handling tools and fixtures, or for processing or transferring components or products. Use is only permitted under the specified environmental conditions.

Misuse

Any use or application deviating from the intended use is deemed to be impermissible misuse. This includes e.g.:

- Transportation of persons and animals
- Use as a climbing aid
- Operation outside the permissible operating parameters
- Use in potentially explosive environments
- Use in underground mining

NOTICE

Changing the structure of the manipulator, e.g. by drilling holes, etc., can result in damage to the components. This is considered improper use and leads to loss of guarantee and liability entitlements.



The robot system is an integral part of a complete system and may only be operated in a CE-compliant system.

3 Product description

3.1 Overview of the robot system

A robot system (>>> Fig. 3-1) comprises all the assemblies of an industrial robot, including the manipulator (mechanical system and electrical installations), control cabinet, connecting cables, end effector (tool) and other equipment. The KR AGILUS sixx product family consists of the following types:

- KR 6 R700 sixx
- KR 6 R900 sixx
- KR 10 R900 sixx
- KR 10 R1100 sixx

The robots are also available as W and C variants (wall-mounted and ceiling-mounted versions).

An industrial robot of this type comprises the following components:

- Manipulator
- Robot controller
- smartPAD teach pendant
- Connecting cables
- Software
- Options, accessories

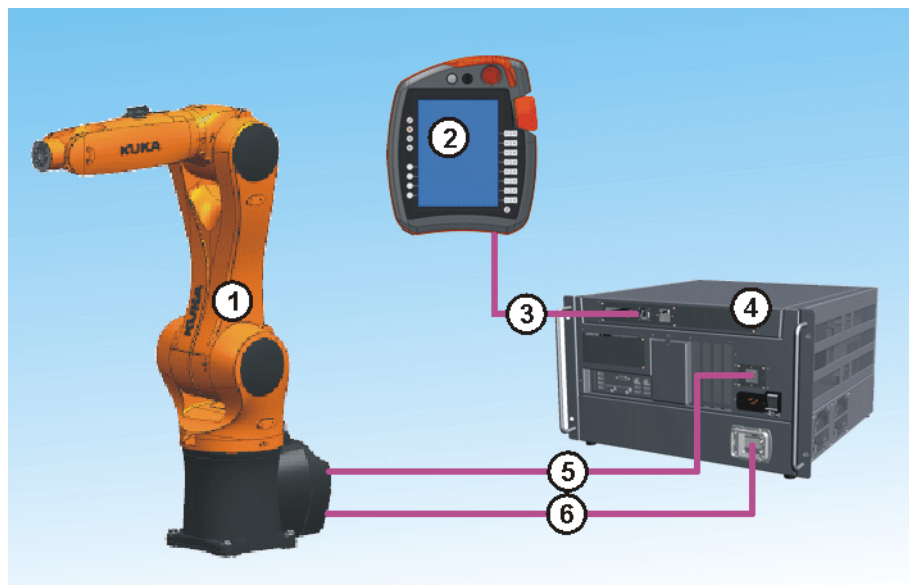

Fig. 3-1: Example of an industrial robot

- 1 Manipulator
- 2 smartPAD teach pendant
- 3 Connecting cable, smartPAD
- 4 Robot controller
- 5 Connecting cable, data cable
- 6 Connecting cable, motor cable

3.2 Description of the manipulator

Overview

The manipulators are 6-axis jointed-arm manipulators made of cast light alloy. Each axis is fitted with a brake. All motor units and current-carrying cables are protected against dirt and moisture beneath screwed-on cover plates.

The robot consists of the following principal components:

- In-line wrist
- Arm
- Link arm
- Rotating column
- Base frame
- Electrical installations

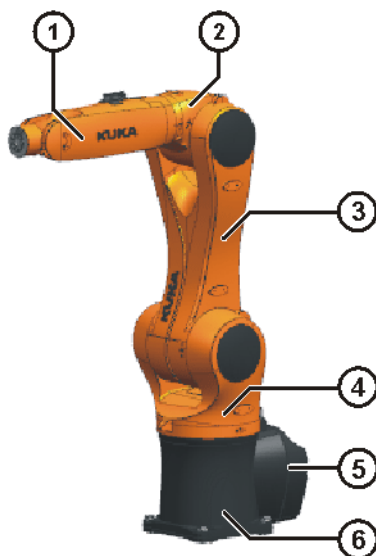

Fig. 3-2: Principal components

- | | | | |
|---|---------------|---|--------------------------|
| 1 | In-line wrist | 4 | Rotating column |
| 2 | Arm | 5 | Electrical installations |
| 3 | Link arm | 6 | Base frame |

In-line wrist A4, A5, A6

The robot is fitted with a 3-axis in-line wrist. The in-line wrist consists of axes 4, 5 and 6.

There are three 5/2-way solenoid valves and a CAT5 data cable in the in-line wrist that can be used for controlling tools.

The in-line wrist also accommodates the 10-contact circular connector of the wrist I/O cable and interface A4 for the energy supply system.

Arm A3

The arm is the link between the in-line wrist and the link arm. The arm is driven by the motor of axis 3.

Link arm A2

The link arm is the assembly located between the arm and the rotating column. It houses the motor and gear unit of axis 2. The supply lines of the energy supply system and the cable set for axes 2 to 6 are routed through the link arm.

Rotating column A1

The rotating column houses the motors of axes 1 and 2. The rotational motion of axis 1 is performed by the rotating column. This is screwed to the base frame via the gear unit of axis 1 and is driven by a motor in the rotating column. The link arm is also mounted in the rotating column.

Base frame	The base frame is the base of the robot. Interface A1 is located at the rear of the base frame. It constitutes the interface for the connecting cables between the robot, the controller and the energy supply system.
Electrical installations	The electrical installations include all the motor and control cables for the motors of axes 1 to 6. All connections are pluggable. The electrical installations also include the RDC box, which is integrated into the robot. The connectors for the motor and data cables are mounted on the robot base frame. The connecting cables from the robot controller are connected here by means of connectors. The electrical installations also include a protective circuit.
Options	The robot can be fitted and operated with various options, e.g. working range limitation A1 or brake release device. The option is described in separate documentation.

4 Technical data

The technical data for the individual robot types can be found in the following sections:

Robot	Technical data
KR 6 sixx	
KR 6 R700 sixx <ul style="list-style-type: none"> ■ KR 6 R700 sixx ■ KR 6 R700 sixx W ■ KR 6 R700 sixx C KR 6 R900 sixx <ul style="list-style-type: none"> ■ KR 6 R900 sixx ■ KR 6 R900 sixx W ■ KR 6 R900 sixx C 	Basic data (>>> 4.1 "Basic data, KR 6 sixx" Page 14)
	Axis data (>>> 4.2 "Axis data, KR 6 sixx" Page 16)
	Payloads (>>> 4.3 "Payloads, KR 6 sixx" Page 24)
	Foundation data (>>> 4.4 "Mounting base data, KR 6 sixx" Page 29)
	Plates and labels (>>> 4.9 "Plates and labels" Page 48)
	Stopping distances <ul style="list-style-type: none"> ■ KR 6 R700 sixx and KR 6 R700 sixx C (>>> 4.10.3 "Stopping distances and times, KR 6 R700 sixx and KR 6 R700 sixx C" Page 51) ■ KR 6 R700 sixx W (>>> 4.10.4 "Stopping distances and times, KR 6 R700 sixx W" Page 56) ■ KR 6 R900 sixx and KR 6 R900 sixx C (>>> 4.10.5 "Stopping distances and times, KR 6 R900 sixx " Page 62) ■ KR 6 R900 sixx W (>>> 4.10.6 "Stopping distances and times, KR 6 R900 sixx W" Page 68)
Robot	Technical data
KR 10 sixx	

Robot	Technical data
KR 10 R900 sixx ■ KR 10 R900 sixx ■ KR 10 R900 sixx W ■ KR 10 R900 sixx C KR 10 R1100 sixx ■ KR 10 R1100 sixx ■ KR 10 R1100 sixx W ■ KR 10 R1100 sixx C	Basic data (>>> 4.5 "Basic data, KR 10 sixx" Page 30)
	Axis data (>>> 4.6 "Axis data, KR 10 sixx" Page 32)
	Payloads (>>> 4.7 "Payloads, KR 10 sixx" Page 41)
	Foundation data (>>> 4.8 "Mounting base data, KR 10 sixx" Page 47)
	Plates and labels (>>> 4.9 "Plates and labels" Page 48)
	Stopping distances ■ KR 10 R900 sixx and KR 10 R900 sixx C (>>> 4.10.7 "Stopping distances and times, KR 10 R900 sixx and KR 10 R1100 sixx" Page 74) ■ KR 10 R900 sixx W (>>> 4.10.8 "Stopping distances and times, KR 10 R900 sixx W and KR 10 R1100 sixx W" Page 80) ■ KR 10 R1100 sixx and KR 10 R1100 sixx C (>>> 4.10.7 "Stopping distances and times, KR 10 R900 sixx and KR 10 R1100 sixx" Page 74) ■ KR 10 R1100 sixx W (>>> 4.10.8 "Stopping distances and times, KR 10 R900 sixx W and KR 10 R1100 sixx W" Page 80)

4.1 Basic data, KR 6 sixx

Basic data

Type	KR 6 R700 sixx KR 6 R700 sixx W KR 6 R700 sixx C KR 6 R900 sixx KR 6 R900 sixx W KR 6 R900 sixx C
Number of axes	6
Volume of working envelope	KR 6 R700 sixx: 1.36 m ³ KR 6 R700 sixx W: 1.36 m ³ KR 6 R700 sixx C: 1.36 m ³ KR 6 R900 sixx: 2.85 m ³ KR 6 R900 sixx W: 2.85 m ³ KR 6 R900 sixx C: 2.85 m ³
Pose repeatability (ISO 9283)	±0.03 mm
Working envelope reference point	Intersection of axes 4 and 5

Weight	KR 6 R700 sixx: approx. 50 kg KR 6 R700 sixx W: approx. 50 kg KR 6 R700 sixx C: approx. 50 kg KR 6 R900 sixx: approx. 52 kg KR 6 R900 sixx W: approx. 52 kg KR 6 R900 sixx C: approx. 52 kg
Principal dynamic loads	See Loads acting on the foundation
Protection classification of the robot	IP 54 ready for operation, with connecting cables plugged in (according to EN 60529)
Protection classification of the in-line wrist	IP 54
Sound level	< 70 dB (A) outside the working envelope
Mounting position	Floor, wall, ceiling
Standard colors	Base (stationary) and covers on link arm: black (RAL 9011); moving parts: KUKA orange 2567

Ambient conditions

Operation	278 K to 318 K (+5 °C to +45 °C) No condensation permissible.
Storage and transportation	-40 °C to +60 °C (233 K to 333 K)
Ambient conditions	Relative air humidity ≤ 90% DIN EN 60721-3-3, Class 3K3
Altitude	<ul style="list-style-type: none"> ■ up to 1000 m above mean sea level with no reduction in power ■ 1000 m ... 4000 m above mean sea level with a reduction in power of 5%/1000 m

The maintenance intervals and the specified service life are based on typical gear unit temperatures and axis motions. If special functions or applications result in atypical gear unit temperatures or axis motions, this can lead to increased wear. In this case, the maintenance intervals or service life may be shortened. If you have any questions, please contact KUKA Customer Support.

Connecting cables

Cable designation	Connector designation robot controller - robot	Interface with robot
Motor cable	X20 - X30	Han Yellock 30
Data cable	X21 - X31	Han Q12
CAT5 data cable (can be ordered as an option)	X65/X66 - XPN1	M12 connector

Cable designation	Connector designation robot controller - robot	Interface with robot
Connecting cable, external axes A7 and A8 (can be ordered as an option)	XP7 - XP7.1 XP8 - XP8.1	Connector M17 in each case
Ground conductor, equipotential bonding (can be ordered as an option)		Ring cable lug M4

Only resolvers can be connected to the connections XP7.1 and XP8.1.

	Cable lengths
Standard	4 m
Optional	1 m, 7 m, 15 m, 25 m

For detailed specifications of the connecting cables, see .

4.2 Axis data, KR 6 sixx

Axis data

The following axis data are valid for the robots:

- KR 6 R700 sixx
- KR 6 R700 sixx W
- KR 6 R700 sixx C
- KR 6 R900 sixx
- KR 6 R900 sixx W
- KR 6 R900 sixx C

Axis	Range of motion, software-limited	Speed with rated payload
1	+/-170°	360 °/s
2	+45° to -190°	300 °/s
3	+156° to -120°	360 °/s
4	+/-185°	381 °/s
5	+/-120°	388 °/s
6	+/-350°	615 °/s

The direction of motion and the arrangement of the individual axes may be noted from the diagram (>>> Fig. 4-1).

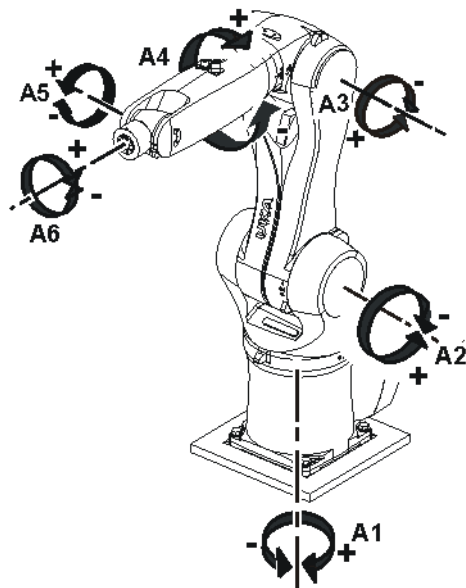

Fig. 4-1: Direction of rotation of robot axes

Working envelope

The following diagram (>>> Fig. 4-2) shows the shape and size of the working envelope for the robot:

- KR 6 R700 sixx

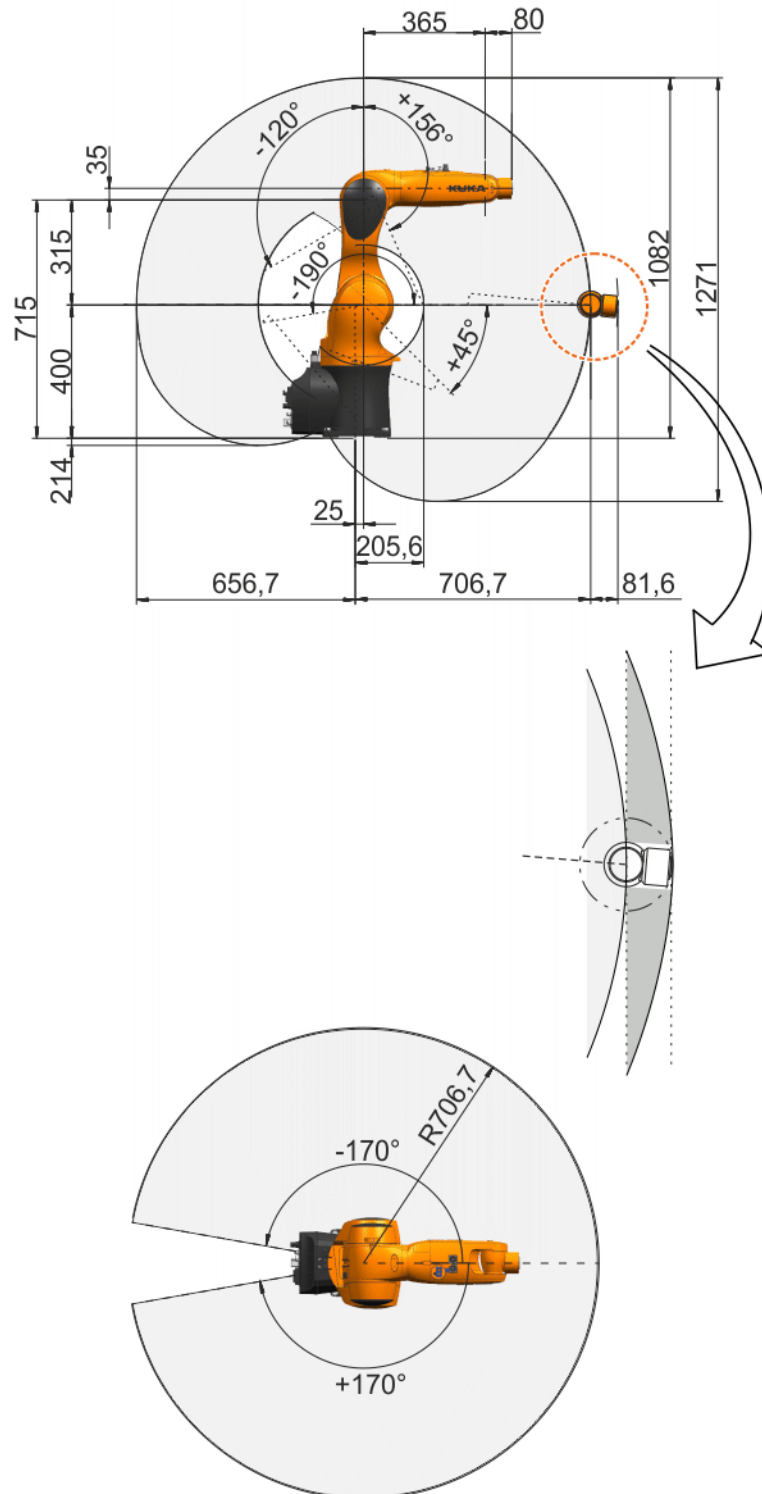

Fig. 4-2: Working envelope, KR 6 R700 sixx

The following diagram (>>> Fig. 4-3) shows the shape and size of the working envelope for the robot:

- KR 6 R700 sixx W

Maße / Dimensions: mm

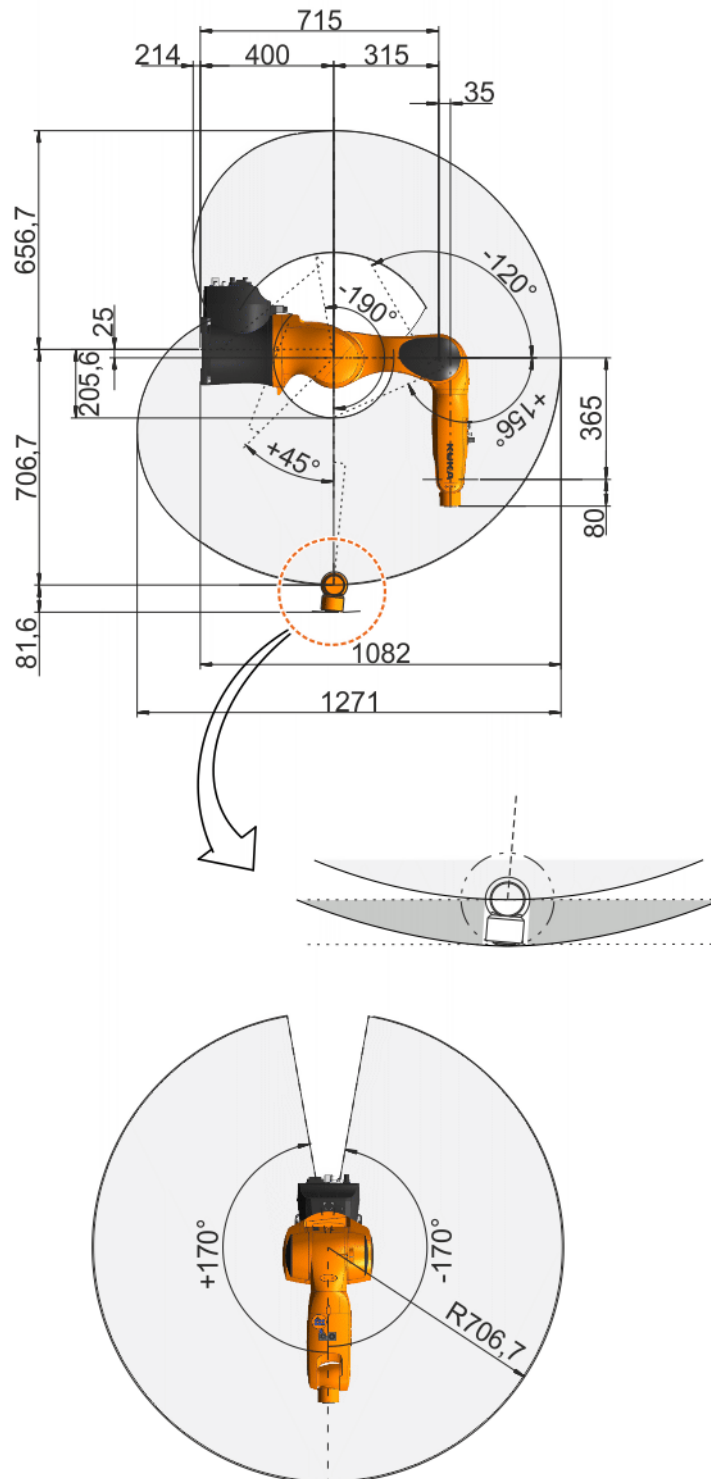

Fig. 4-3: Working envelope, KR 6 R700 sixx W

The following diagram (>>> Fig. 4-4) shows the shape and size of the work-
ing envelope for the robot:

- KR 6 R700 sixx C

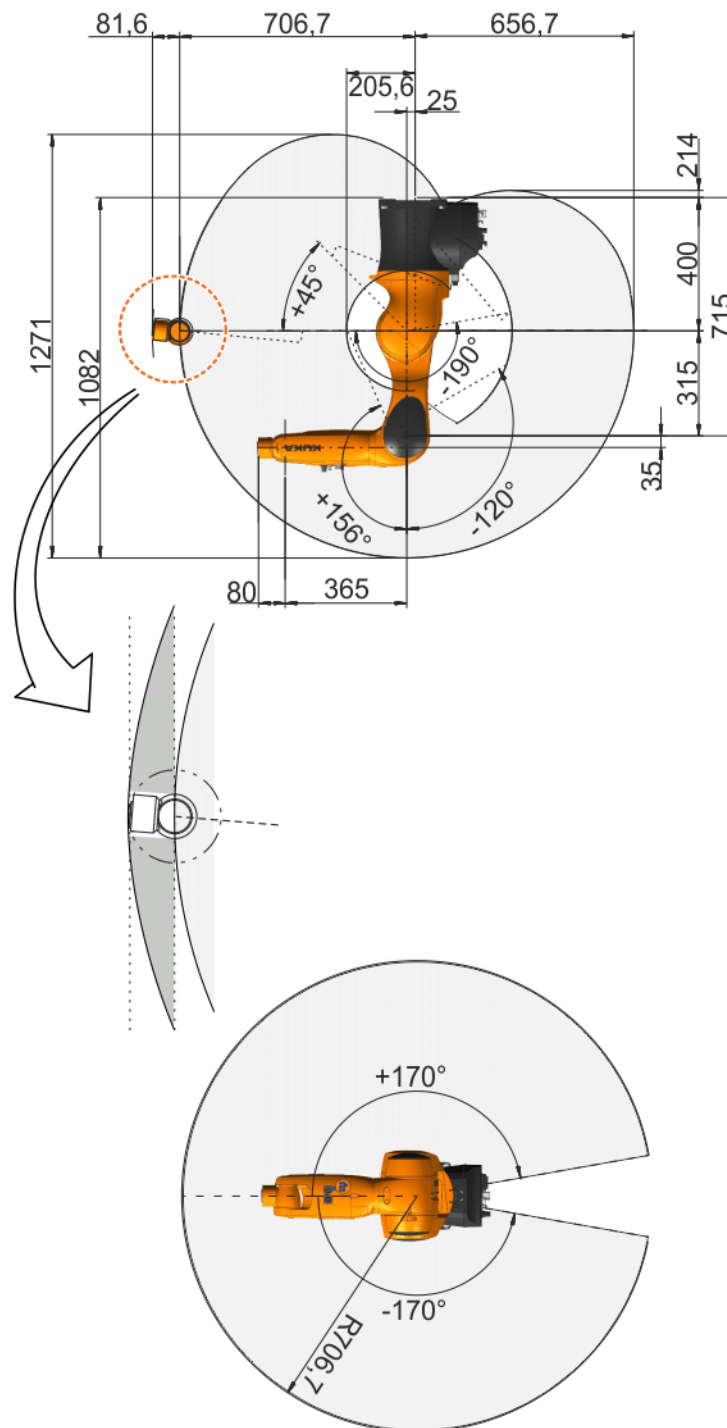

Fig. 4-4: Working envelope, KR 6 R700 sixx C

The following diagram (>>> Fig. 4-5) shows the shape and size of the working envelope for the robot:

- KR 6 R900 sixx

Maße / Dimensions: mm

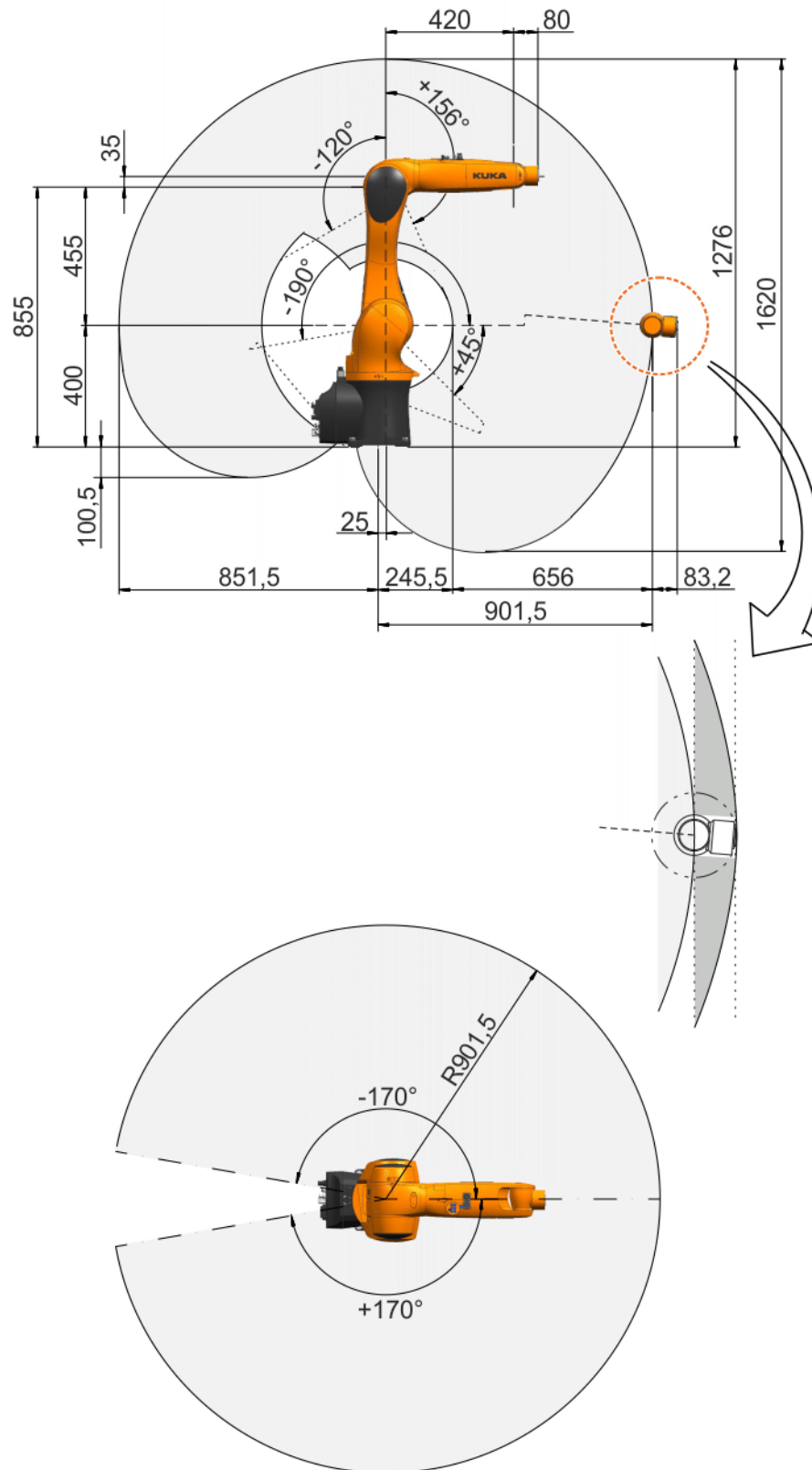

Fig. 4-5: Working envelope, KR 6 R900 sixx

The following diagram (>>> Fig. 4-6) shows the shape and size of the working envelope for the robot:

- KR 6 R900 sixx W

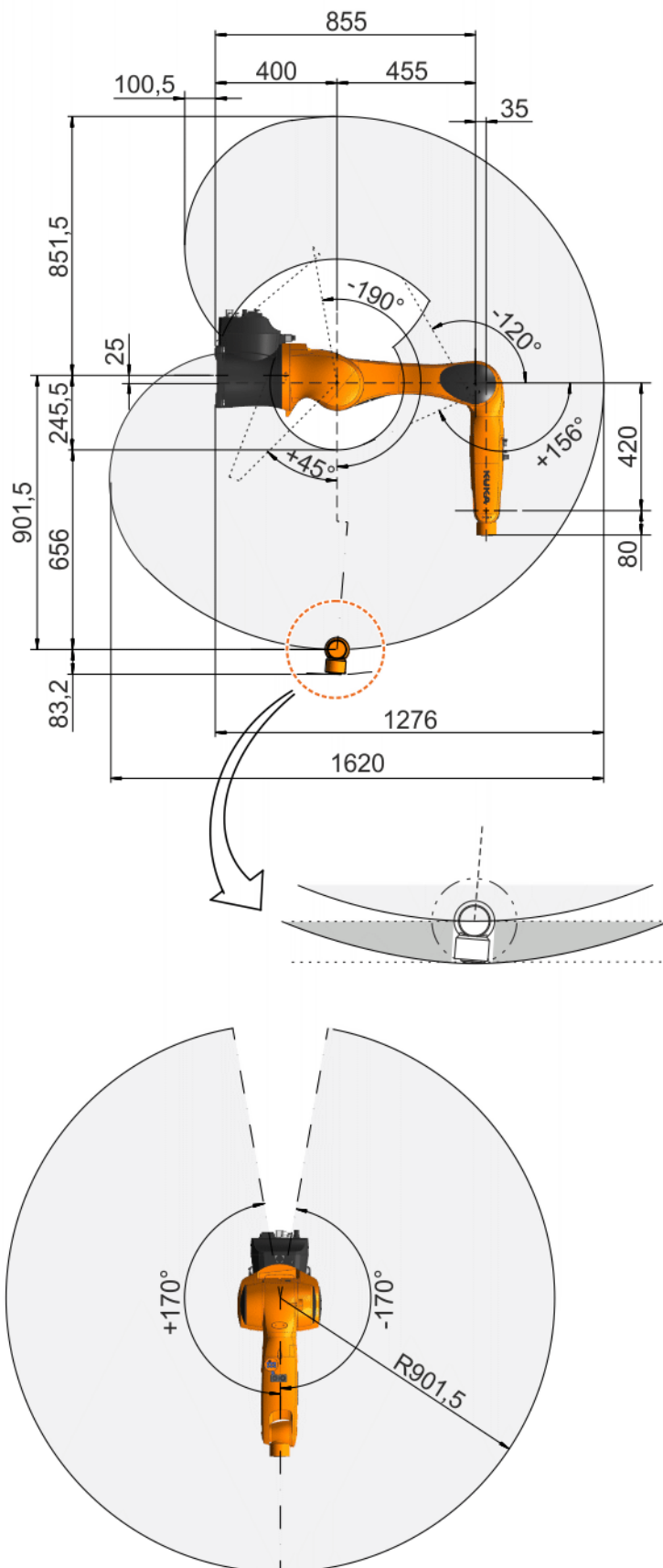

Fig. 4-6: Working envelope, KR 6 R900 sixx W

The following diagram (>>> Fig. 4-7) shows the shape and size of the working envelope for the robot:

- KR 6 R900 sixx C

Maße / Dimensions: mm

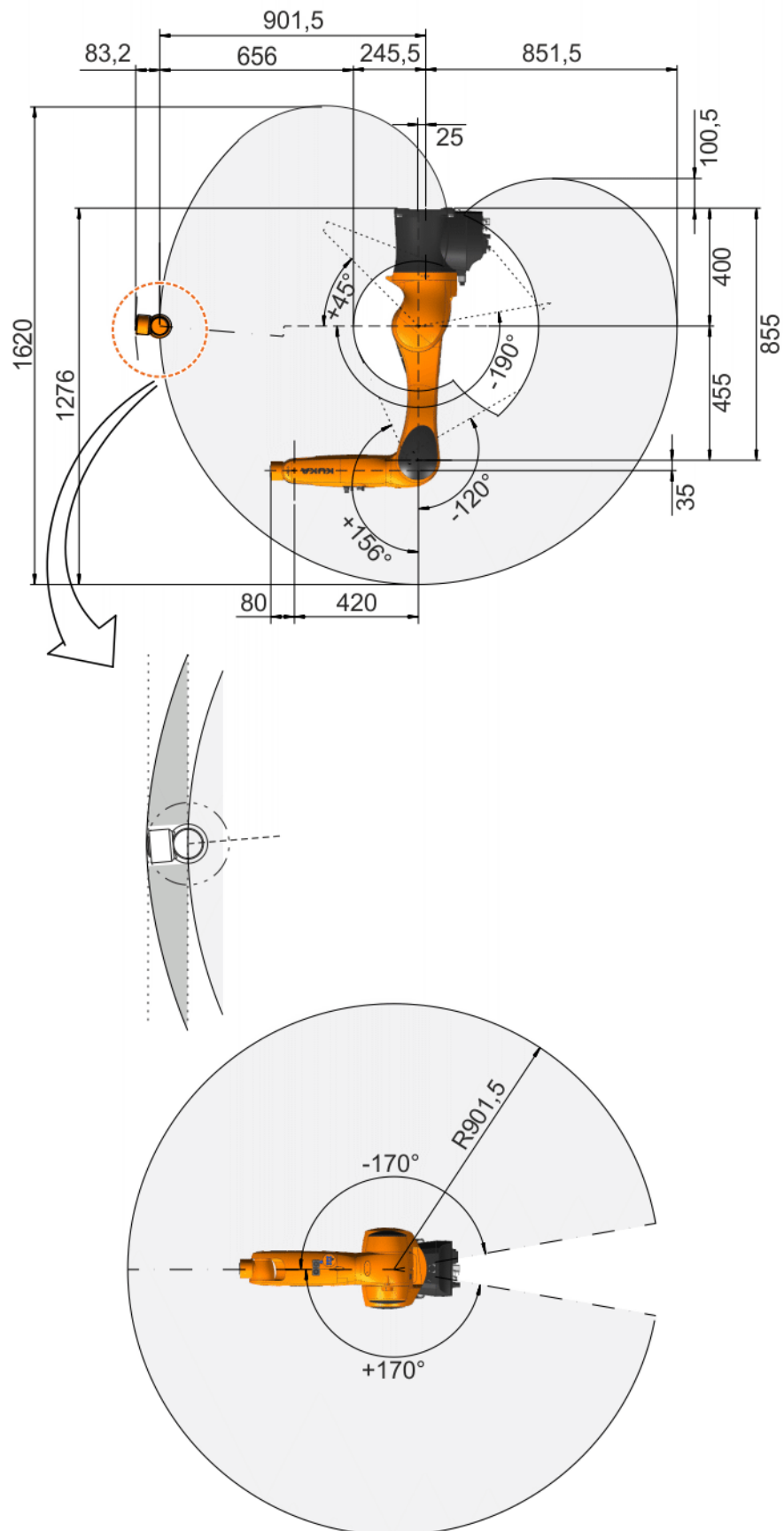

Fig. 4-7: Working envelope, KR 6 R900 sixx C

4.3 Payloads, KR 6 sixx

Payloads

A distinction is made between the nominal and maximum payload. At the nominal payload, the manipulator is rated for optimal cycle times and accuracy.

Robot	KR 6 R700 sixx KR 6 R700 sixx W KR 6 R700 sixx C KR 6 R900 sixx KR 6 R900 sixx W KR 6 R900 sixx C
In-line wrist	KR 6 R700 sixx: IW 6 R700 KR 6 R900 sixx: IW 6/10 R900
Rated payload	3 kg
Max. payload	6 kg
Distance of the load center of gravity L_{xy}	60 mm
Distance of the load center of gravity L_z	80 mm
Max. total load	6 kg
Supplementary load	The sum of all loads mounted on the robot must not exceed the maximum total load.

Load center of gravity P

For all payloads, the load center of gravity refers to the distance from the face of the mounting flange on axis 6. Refer to the payload diagram for the nominal distance.

Payload diagram

Permissible mass inertia at the design point (L_x , L_y , L_z) is 0.045 kgm².

The following figure (>>> Fig. 4-8) shows payload diagram for the following robots:

- KR 6 R700 sixx
- KR 6 R700 sixx W
- KR 6 R700 sixx C
- KR 6 R900 sixx
- KR 6 R900 sixx W
- KR 6 R900 sixx C

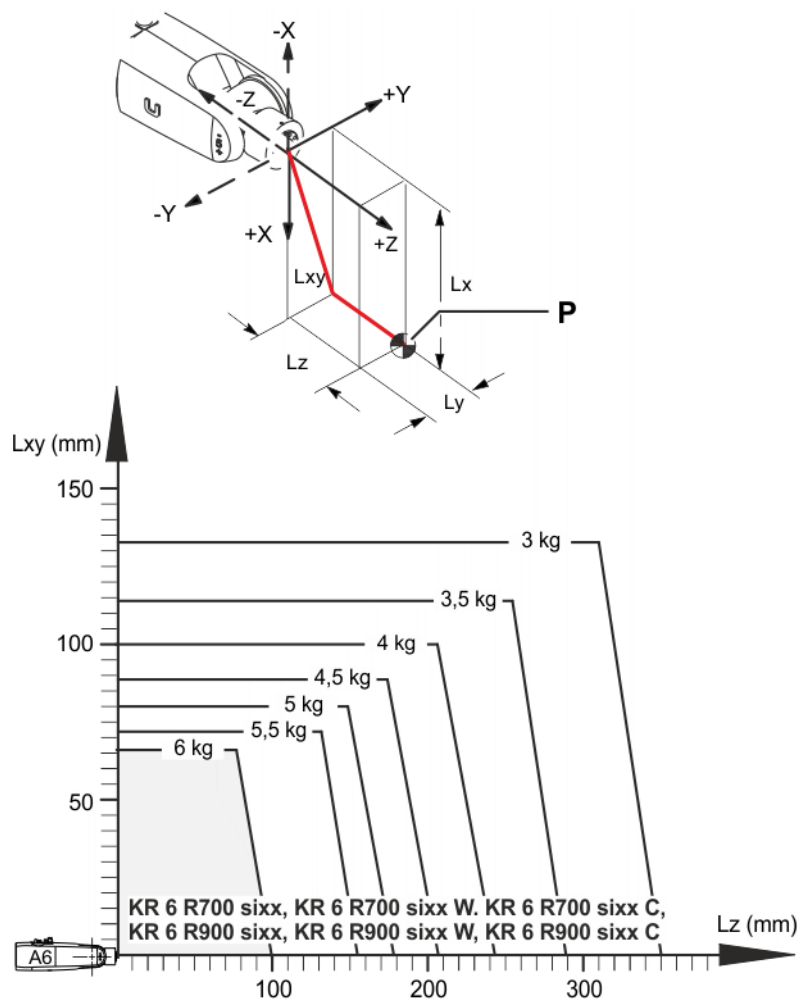

Fig. 4-8: Payload diagram

NOTICE This loading curve corresponds to the maximum load capacity. Both values (payload and mass moment of inertia) must be checked in all cases. Exceeding this capacity will reduce the service life of the robot and overload the motors and the gears; in any such case the KUKA Roboter GmbH must be consulted beforehand. The values determined here are necessary for planning the robot application. For commissioning the robot, additional input data are required in accordance with operating and programming instructions of the KUKA System Software. The mass inertia must be verified using KUKA.Load. It is imperative for the load data to be entered in the robot controller!

Mounting flange

Mounting flange	ISO 9409-1: 2004
Screw grade	12.9
Screw size	M5
Grip length	1.5 x nominal diameter
Depth of engagement	min. 5.5 mm, max. 7 mm
Locating element	5 H7

The mounting flange is depicted (>>> Fig. 4-9) with axis 6 in the zero position. The symbol X_m indicates the position of the locating element (bushing) in the zero position.

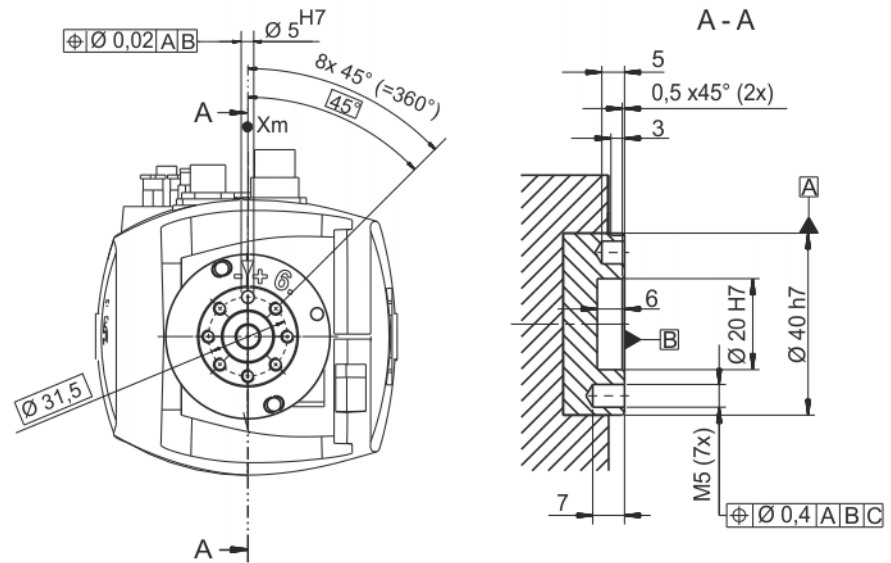

Fig. 4-9: Mounting flange

Supplementary load

The robot can carry supplementary loads on the arm, on the wrist, on the link arm and on the rotating column. The fastening holes are used for fastening the covers or external energy supply systems. When mounting the supplementary loads, be careful to observe the maximum permissible total load. The dimensions and positions of the installation options can be seen in the following diagram.



The sum of all loads mounted on the robot must not exceed the maximum total load.

The following figure (>>> Fig. 4-10) shows the dimensions and position of the installation options on the arm and in-line wrist for the following robots:

- KR 6 R700 sixx
- KR 6 R700 sixx W
- KR 6 R700 sixx C

Maße / Dimensions: mm

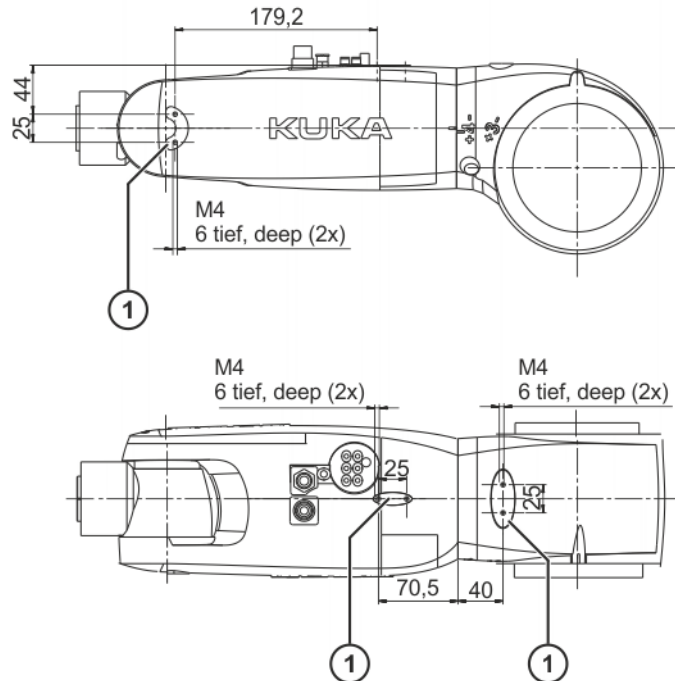

Fig. 4-10: Supplementary load on arm and in-line wrist

- 1 Support bracket for supplementary load

The following figure (>>> Fig. 4-11) shows the dimensions and position of the installation options on the link arm and rotating column for the following robots:

- KR 6 R700 sixx
- KR 6 R700 sixx W
- KR 6 R700 sixx C

Maße / Dimensions: mm

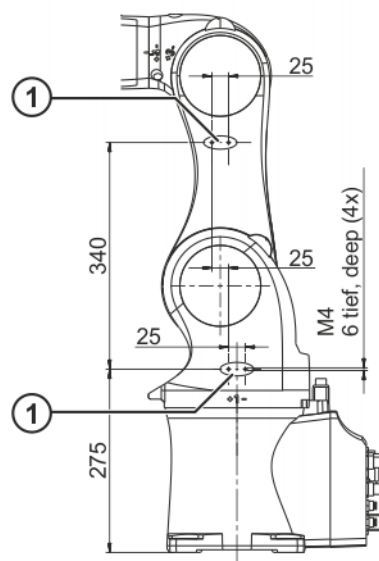

Fig. 4-11: Supplementary load on link arm and rotating column

- 1 Support bracket for supplementary load

The following figure (>>> Fig. 4-12) shows the dimensions and position of the installation options on the arm and in-line wrist for the following robots:

- KR 6 R900 sixx
- KR 6 R900 sixx W
- KR 6 R900 sixx C

Maße / Dimensions: mm

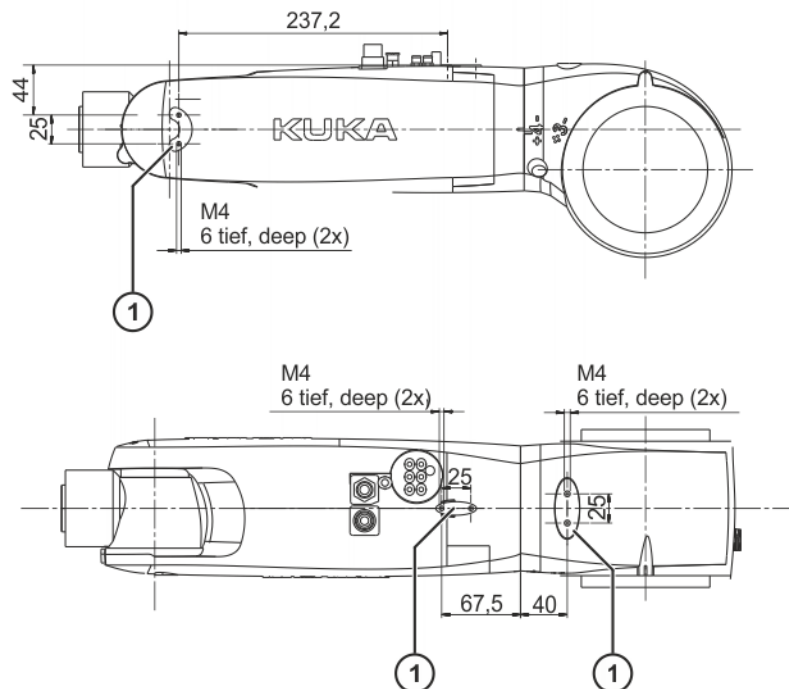

Fig. 4-12: Supplementary load on arm and in-line wrist

- 1 Support bracket for supplementary load

The following figure (>>> Fig. 4-13) shows the dimensions and position of the installation options on the link arm and rotating column for the following robots:

- KR 6 R900 sixx
- KR 6 R900 sixx W
- KR 6 R900 sixx C

Maße / Dimensions: mm

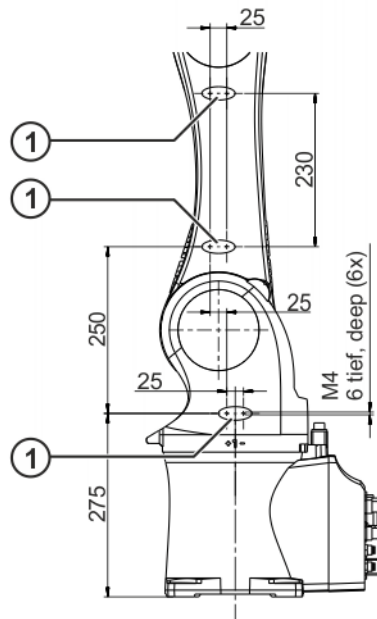

Fig. 4-13: Supplementary load on link arm and rotating column

- 1 Support bracket for supplementary load

4.4 Mounting base data, KR 6 sixx

Foundation loads The specified forces and moments already include the maximum payload and the inertia force (weight) of the robot.

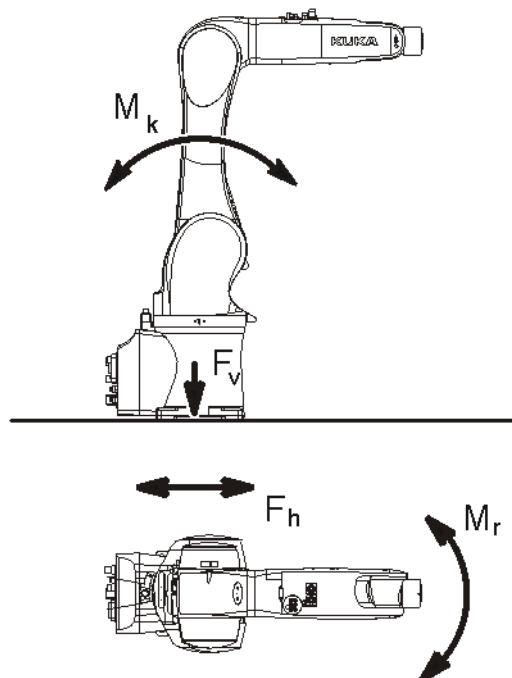

Fig. 4-14: Loads acting on the foundation

Type of load	Force/torque/mass	
	Normal operation	Maximum load
F_v = vertical force	$F_{vmax} = 967 \text{ N}$	$F_{vmax} = 1297 \text{ N}$
F_h = horizontal force	$F_{hmax} = 1223 \text{ N}$	$F_{hmax} = 1362 \text{ N}$
M_k = tilting moment	$M_{kmax} = 788 \text{ Nm}$	$M_{kmax} = 1152 \text{ Nm}$
M_r = torque	$M_{rmax} = 367 \text{ Nm}$	$M_{rmax} = 880 \text{ Nm}$
Total mass for load acting on the foundation	KR 6 R700 sixx: 56 kg KR 6 R900 sixx: 58 kg	
Robot	KR 6 R700 sixx: 50 kg KR 6 R900 sixx: 52 kg	
Total load for foundation load (suppl. load on arm + rated payload)	KR 6 R700 sixx: 6 kg KR 6 R900 sixx: 6 kg	

NOTICE

The foundation loads specified in the table are the maximum loads that may occur. They must be referred to when dimensioning the foundations and must be adhered to for safety reasons. Failure to do so may result in material damage. The supplementary loads are not taken into consideration in the calculation of the foundation load. These supplementary loads must be taken into consideration for F_v .

4.5 Basic data, KR 10 sixx

Basic data

Type	KR 10 R900 sixx KR 10 R900 sixx W KR 10 R900 sixx C KR 10 R1100 sixx KR 10 R1100 sixx W KR 10 R1100 sixx C
Number of axes	6
Volume of working envelope	KR 10 R900 sixx: 2.85 m ³ KR 10 R900 sixx W: 2.85 m ³ KR 10 R900 sixx C: 2.85 m ³ KR 10 R1100 sixx: 5.20 m ³ KR 10 R1100 sixx W: 5.20 m ³ KR 10 R1100 sixx C: 5.20 m ³
Pose repeatability (ISO 9283)	±0.03 mm
Working envelope reference point	Intersection of axes 4 and 5

Weight	KR 10 R900 sixx: approx. 52 kg KR 10 R900 sixx W: approx. 52 kg KR 10 R900 sixx C: approx. 52 kg KR 10 R1100 sixx: approx. 55 kg KR 10 R1100 sixx W: approx. 55 kg KR 10 R1100 sixx C: approx. 55 kg
Principal dynamic loads	See Loads acting on the foundation
Protection classification of the robot	IP 54 ready for operation, with connecting cables plugged in (according to EN 60529)
Protection classification of the in-line wrist	IP 54
Sound level	< 70 dB (A) outside the working envelope
Mounting position	Floor, wall, ceiling
Standard colors	Base (stationary) and covers on link arm: black (RAL 9011); moving parts: KUKA orange 2567

Ambient conditions

Operation	278 K to 318 K (+5 °C to +45 °C) No condensation permissible.
Storage and transportation	-40 °C to +60 °C (233 K to 333 K)
Ambient conditions	Relative air humidity ≤ 90% DIN EN 60721-3-3, Class 3K3
Altitude	<ul style="list-style-type: none"> ■ up to 1000 m above mean sea level with no reduction in power ■ 1000 m ... 4000 m above mean sea level with a reduction in power of 5%/1000 m

The maintenance intervals and the specified service life are based on typical gear unit temperatures and axis motions. If special functions or applications result in atypical gear unit temperatures or axis motions, this can lead to increased wear. In this case, the maintenance intervals or service life may be shortened. If you have any questions, please contact KUKA Customer Support.

Connecting cables

Cable designation	Connector designation robot controller - robot	Interface with robot
Motor cable	X20 - X30	Han Yellock 30
Data cable	X21 - X31	Han Q12
CAT5 data cable (can be ordered as an option)	X65/X66 - XPN1	M12 connector

Cable designation	Connector designation robot controller - robot	Interface with robot
Connecting cable, external axes A7 and A8 (can be ordered as an option)	XP7 - XP7.1 XP8 - XP8.1	Connector M17 in each case
Ground conductor, equipotential bonding (can be ordered as an option)		Ring cable lug M4

Only resolvers can be connected to the connections XP7.1 and XP8.1.

	Cable lengths
Standard	4 m
Optional	1 m, 7 m, 15 m, 25 m

For detailed specifications of the connecting cables, see .

4.6 Axis data, KR 10 sixx

Axis data

The following axis data are valid for the robots:

- KR 10 R900 sixx
- KR 10 R900 sixx W
- KR 10 R900 sixx C
- KR 10 R1100 sixx
- KR 10 R1100 sixx W
- KR 10 R1100 sixx C

Axis	Range of motion, software-limited	Speed with rated payload
1	+/-170°	300 °/s
2	+45° to -190°	225 °/s
3	+156° to -120°	225 °/s
4	+/-185°	381 °/s
5	+/-120°	311 °/s
6	+/-350°	492 °/s

The direction of motion and the arrangement of the individual axes may be noted from the diagram (>>> Fig. 4-15).

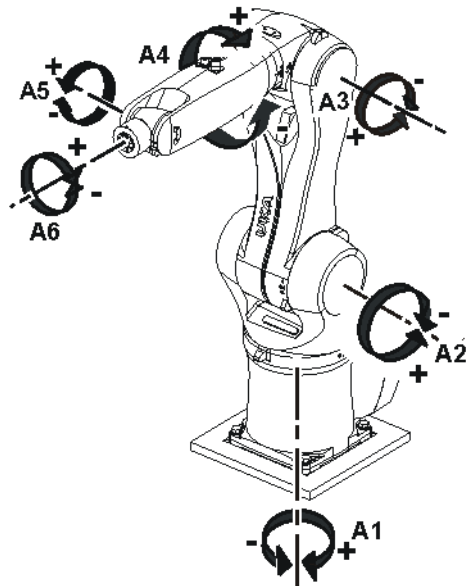

Fig. 4-15: Direction of rotation of robot axes

Working envelope

The following diagram (>>> Fig. 4-16) shows the shape and size of the working envelope for the robot:

- KR 10 R900 sixx

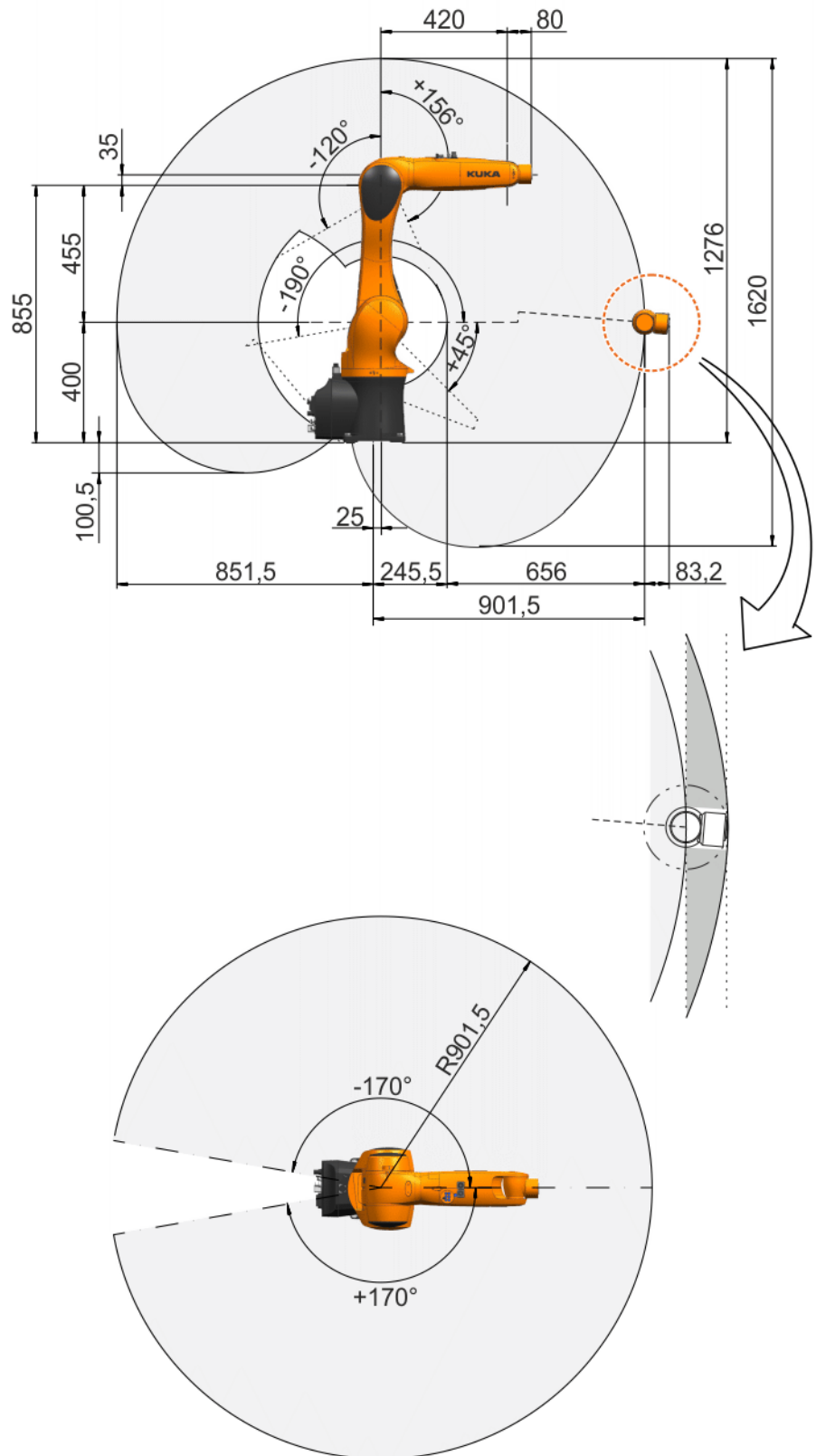

Fig. 4-16: Working envelope, KR 10 R900 sixx

The following diagram (>>> Fig. 4-17) shows the shape and size of the working envelope for the robot:

- KR 10 R900 sixx W

Maße / Dimensions: mm

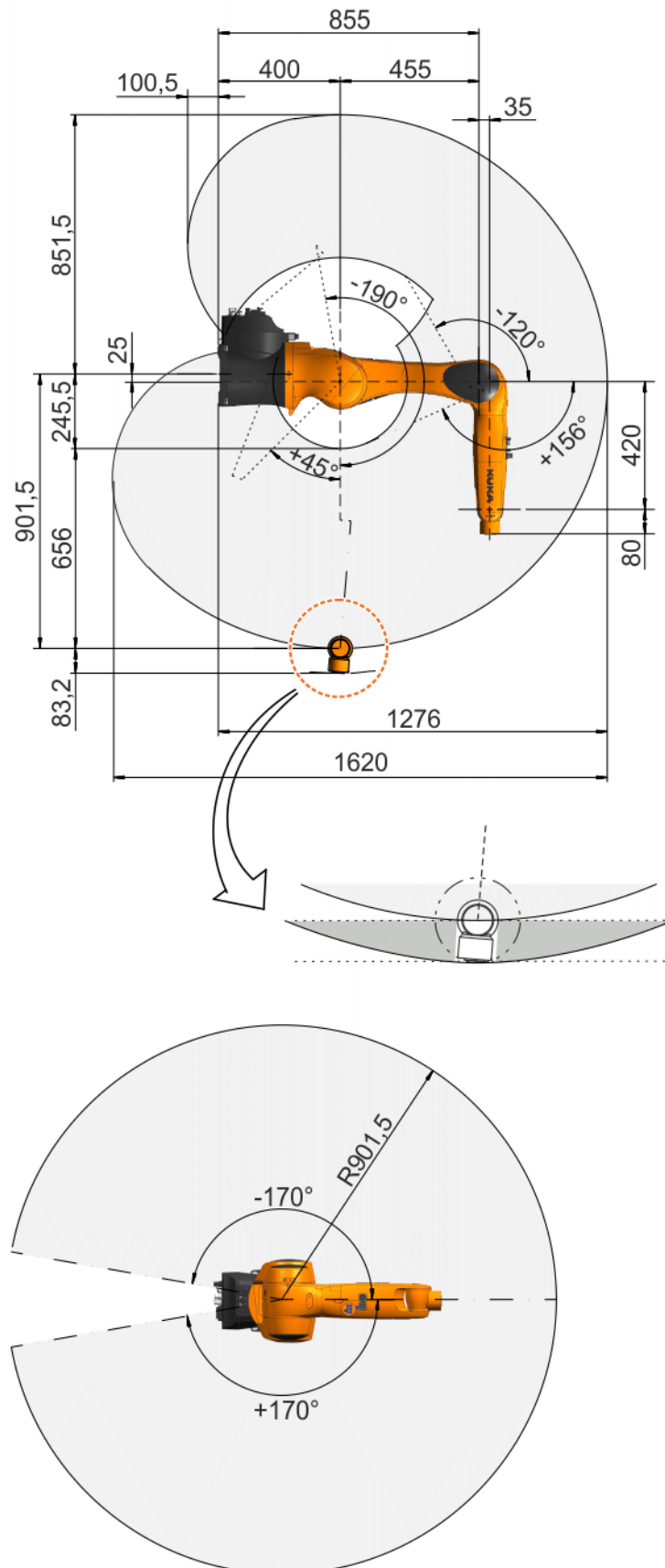

Fig. 4-17: Working envelope, KR 10 R900 sixx W

The following diagram (>>> Fig. 4-18) shows the shape and size of the working envelope for the robot:

■ KR 10 R900 sixx C

Maße / Dimensions: mm

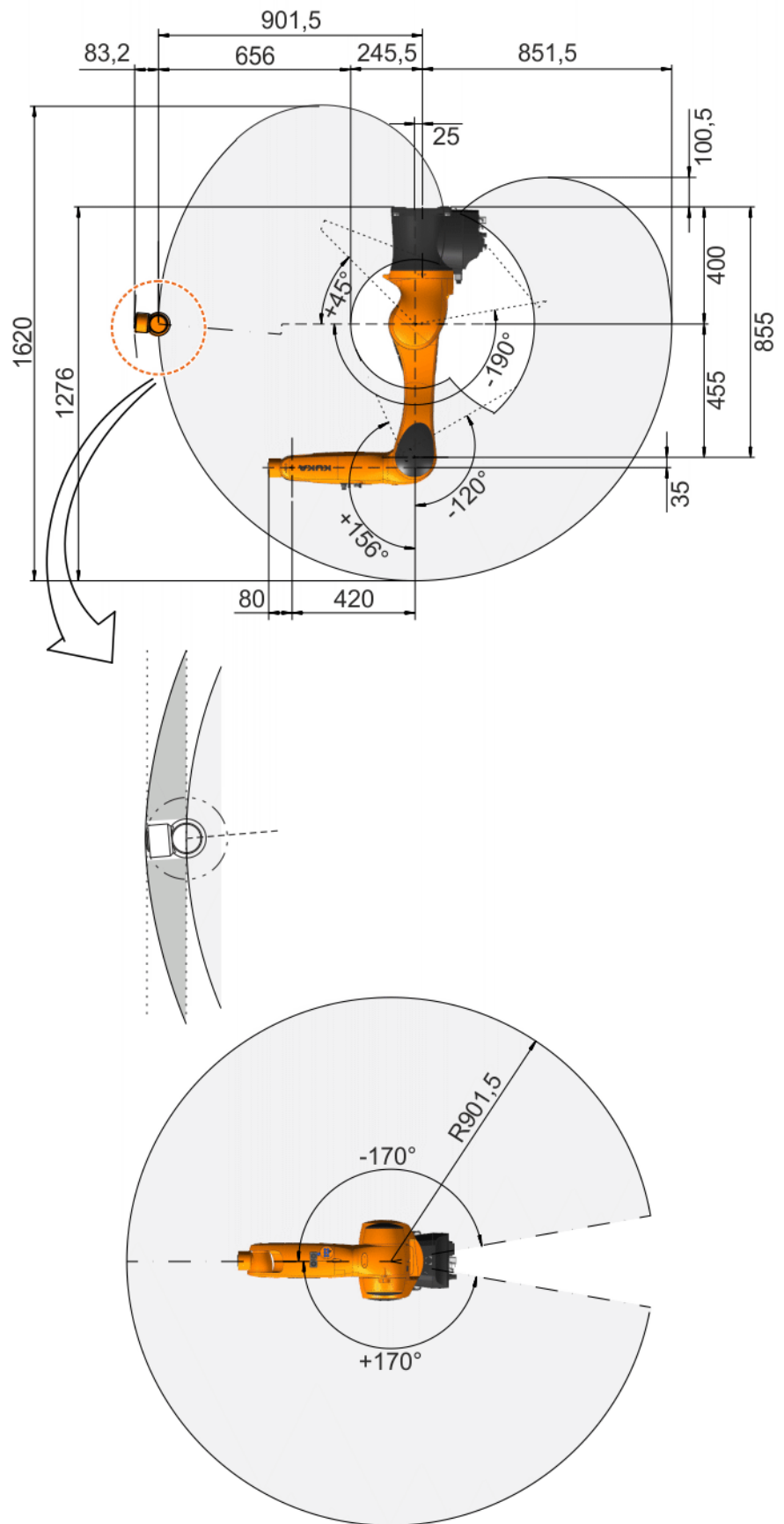

Fig. 4-18: Working envelope, KR 10 R900 sixx C

The following diagram (>>> Fig. 4-19) shows the shape and size of the working envelope for the robot:

- KR 10 R1100 sixx

Maße / Dimensions: mm

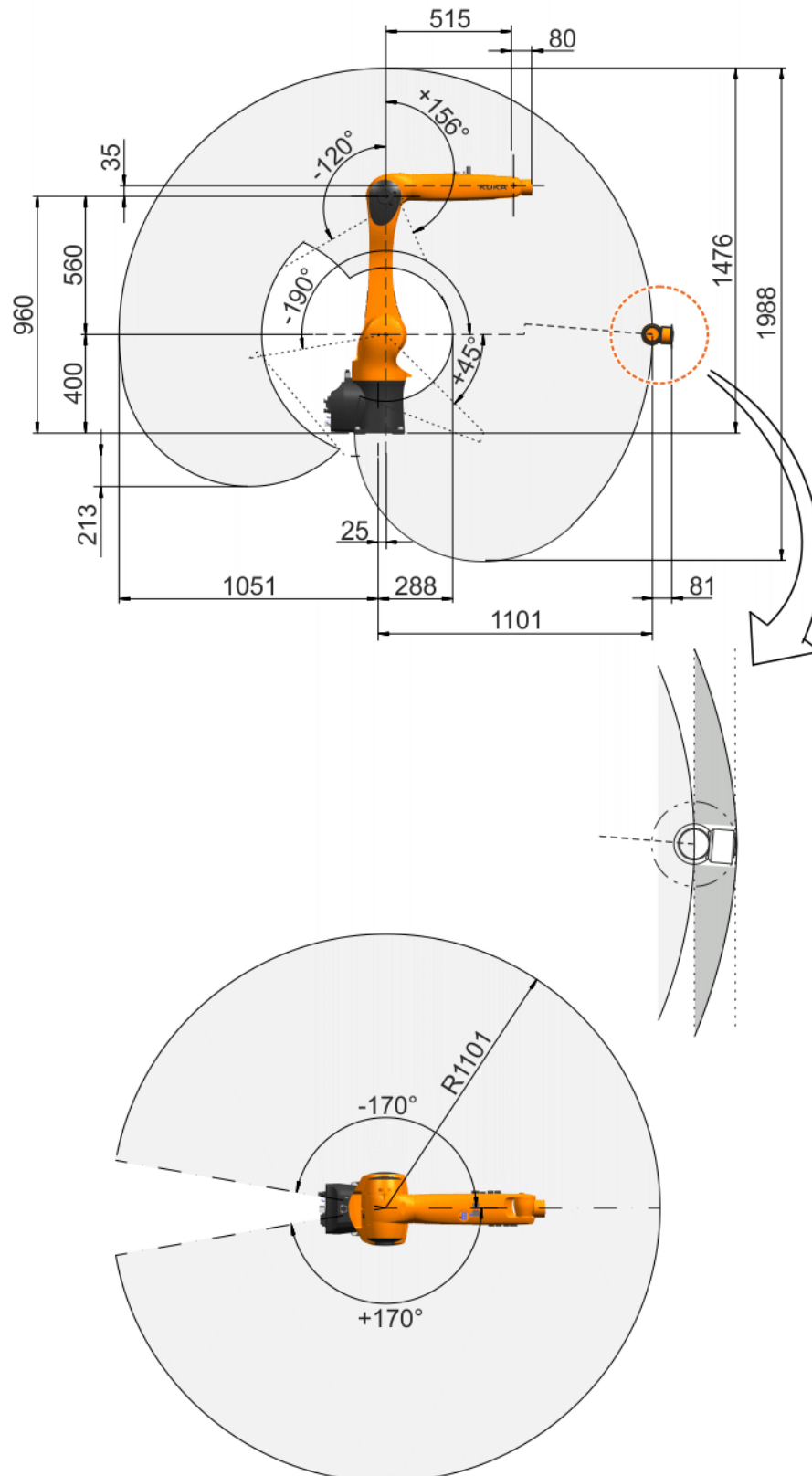

Fig. 4-19: Working envelope, KR 10 R1100 sixx

The following diagram (>>> Fig. 4-20) shows the shape and size of the working envelope for the robot:

- KR 10 R1100 sixx W

Maße / Dimensions: mm

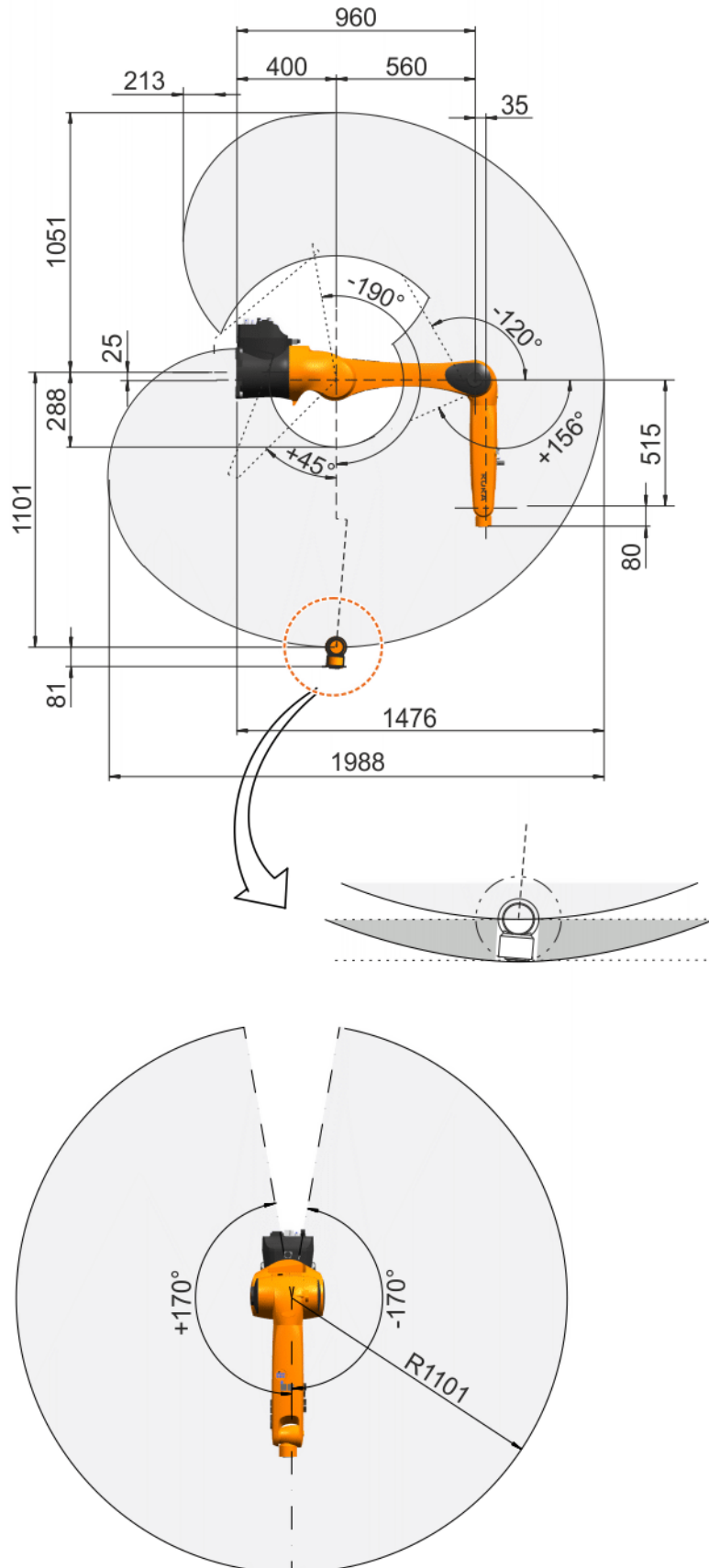

Fig. 4-20: Working envelope, KR 10 R1100 sixx W

The following diagram (>>> Fig. 4-21) shows the shape and size of the working envelope for the robot:

■ KR 10 R1100 sixx C

Maße / Dimensions: mm

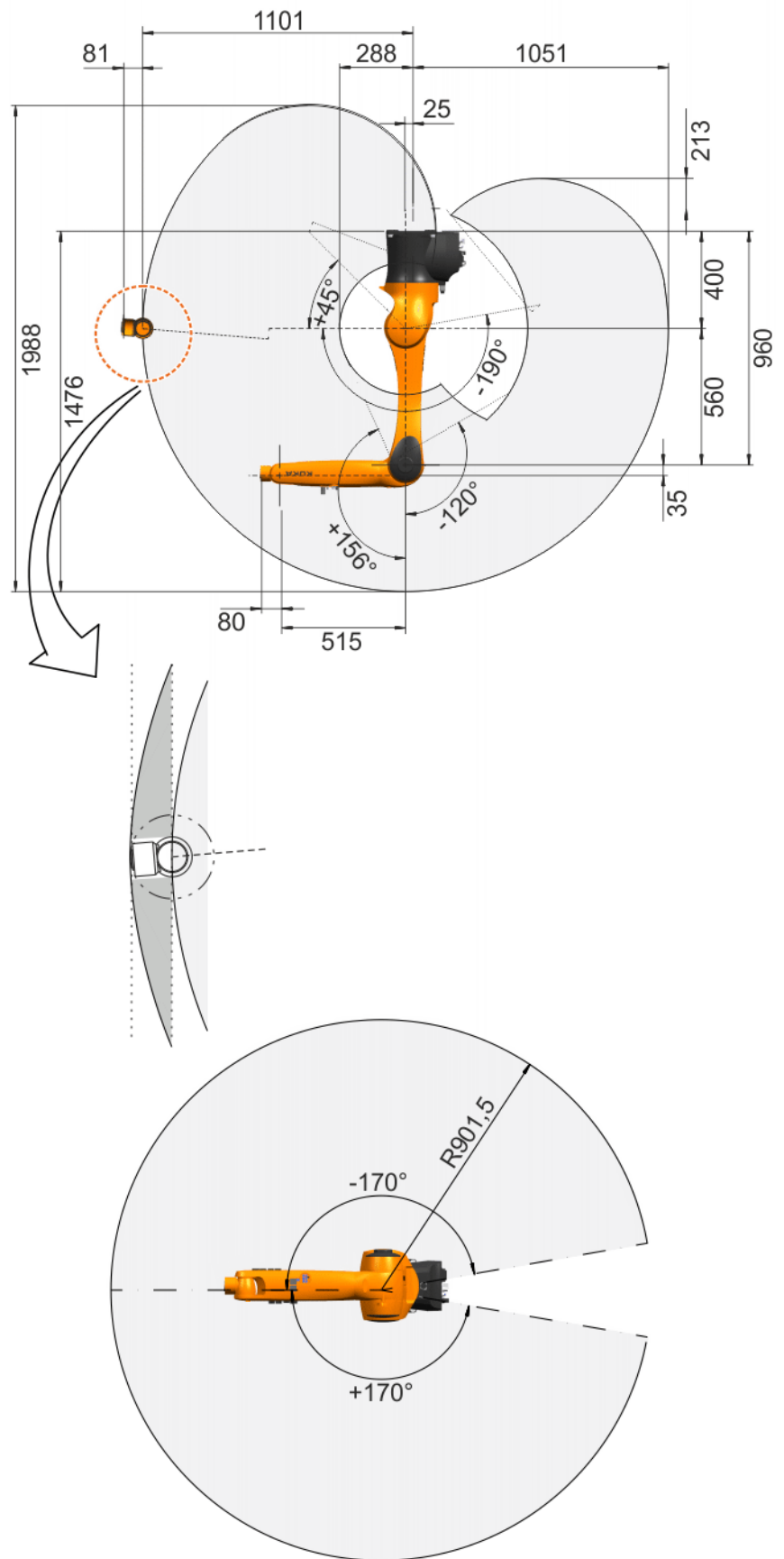

Fig. 4-21: Working envelope, KR 10 R1100 sixx C

4.7 Payloads, KR 10 sixx

Payloads

A distinction is made between the nominal and maximum payload. At the nominal payload, the manipulator is rated for optimal cycle times and accuracy.

Robot	KR 10 R900 sixx KR 10 R900 sixx W KR 10 R900 sixx C KR 10 R1100 sixx KR 10 R1100 sixx W KR 10 R1100 sixx C
In-line wrist	KR 10 R900 sixx: IW 6/10 R900 KR 10 R1100 sixx: IW 10 R1100
Rated payload	5 kg
Max. payload	10 kg
Distance of the load center of gravity L_{xy}	100 mm
Distance of the load center of gravity L_z	80 mm
Max. total load	10 kg
Supplementary load	The sum of all loads mounted on the robot must not exceed the maximum total load.

Load center of gravity P

For all payloads, the load center of gravity refers to the distance from the face of the mounting flange on axis 6. Refer to the payload diagram for the nominal distance.

Payload diagram

Permissible mass inertia at the design point (L_x , L_y , L_z) is 0.045 kgm².

The following figure (>>> Fig. 4-22) shows payload diagram for the following robots:

- KR 10 R900 sixx
- KR 10 R900 sixx W
- KR 10 R900 sixx C

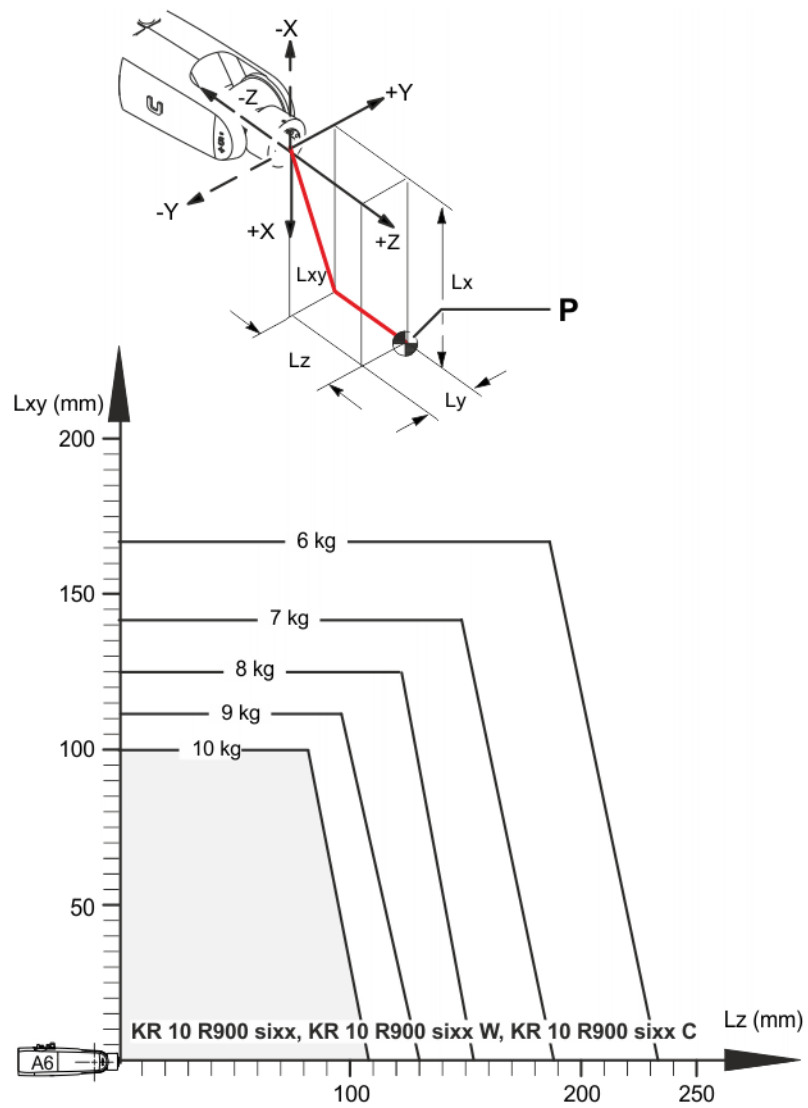

Fig. 4-22: Payload diagram, KR 10 R900 sixx

The following figure (>>> Fig. 4-23) shows payload diagram for the following robots:

- KR 10 R1100 sixx
- KR 10 R1100 sixx W
- KR 10 R1100 sixx C

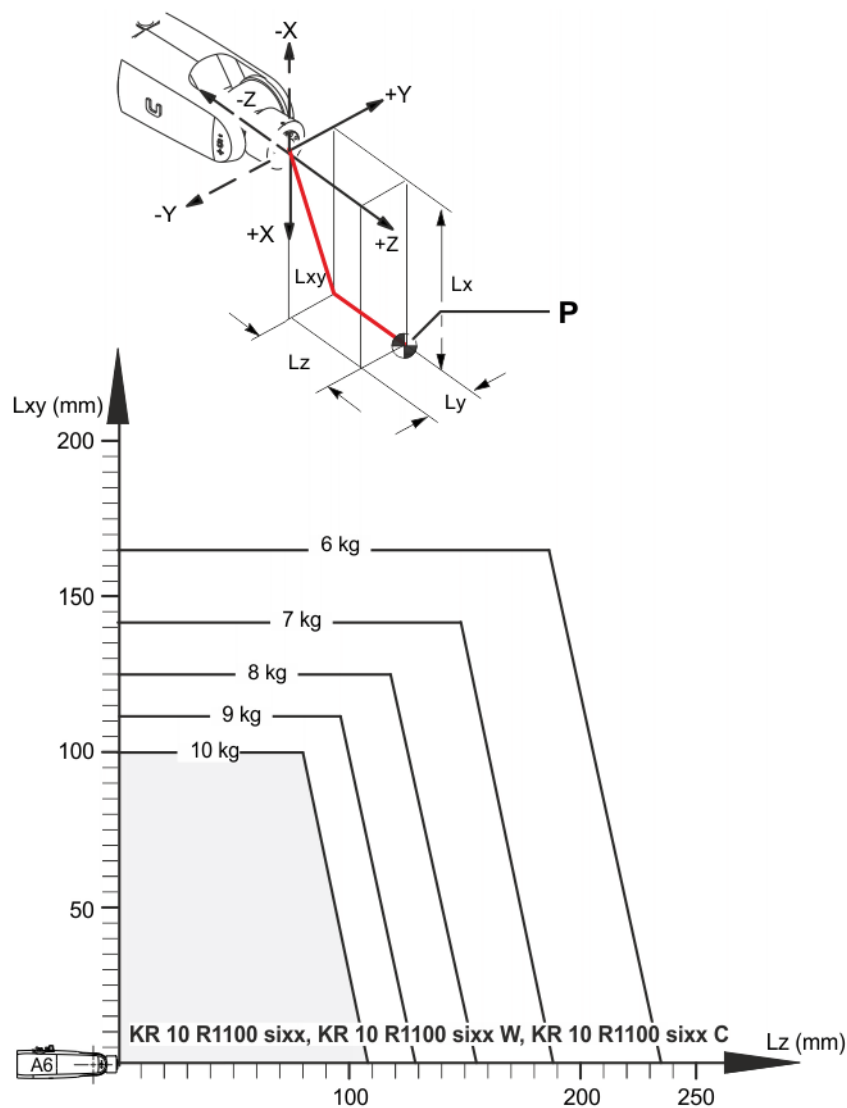

Fig. 4-23: Payload diagram, KR 10 R1100 sixx

NOTICE

This loading curve corresponds to the maximum load capacity. Both values (payload and mass moment of inertia) must be checked in all cases. Exceeding this capacity will reduce the service life of the robot and overload the motors and the gears; in any such case the KUKA Roboter GmbH must be consulted beforehand. The values determined here are necessary for planning the robot application. For commissioning the robot, additional input data are required in accordance with operating and programming instructions of the KUKA System Software. The mass inertia must be verified using KUKA.Load. It is imperative for the load data to be entered in the robot controller!

Mounting flange

Mounting flange	ISO 9409-1: 2004
Screw grade	12.9
Screw size	M5
Grip length	1.5 x nominal diameter
Depth of engagement	min. 5.5 mm, max. 7 mm
Locating element	5 H7

The mounting flange is depicted (>>> Fig. 4-24) with axis 6 in the zero position. The symbol X_m indicates the position of the locating element (bushing) in the zero position.

Maße / Dimensions: mm

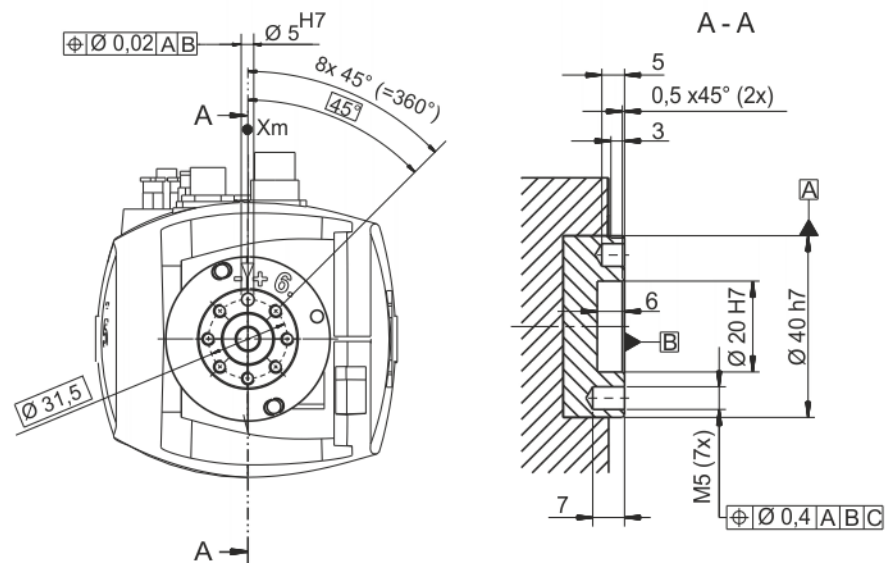

Fig. 4-24: Mounting flange

Supplementary load

The robot can carry supplementary loads on the arm, on the wrist, on the link arm and on the rotating column. The fastening holes are used for fastening the covers or external energy supply systems. When mounting the supplementary loads, be careful to observe the maximum permissible total load. The dimensions and positions of the installation options can be seen in the following diagram.



The sum of all loads mounted on the robot must not exceed the maximum total load.

The following figure (>>> Fig. 4-25) shows the dimensions and position of the installation options on the arm and in-line wrist for the following robots:

- KR 10 R900 sixx
- KR 10 R900 sixx W
- KR 10 R900 sixx C

Maße / Dimensions: mm

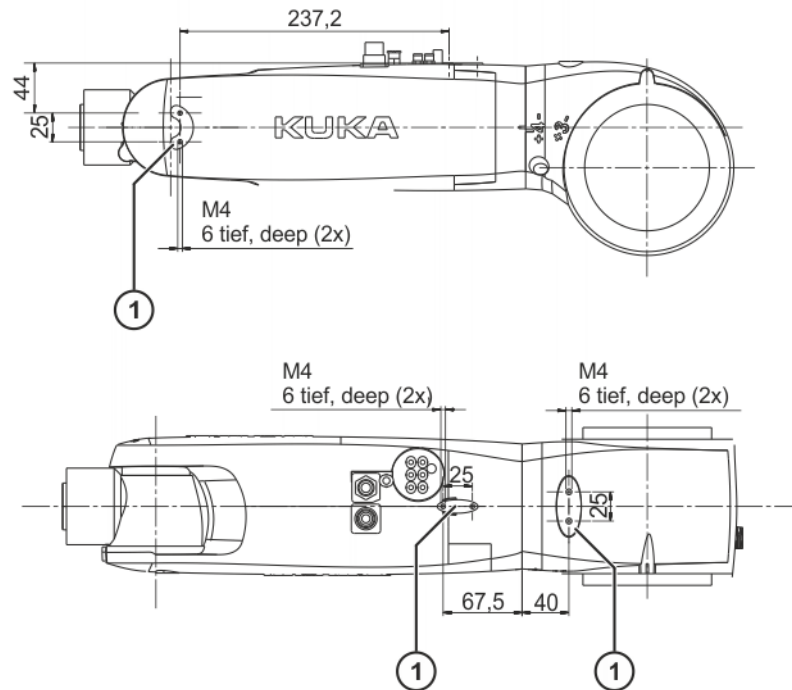

Fig. 4-25: Supplementary load on arm and in-line wrist

- 1 Support bracket for supplementary load

The following figure (>>> Fig. 4-26) shows the dimensions and position of the installation options on the link arm and rotating column for the following robots:

- KR 10 R900 sixx
- KR 10 R900 sixx W
- KR 10 R900 sixx C

Maße / Dimensions: mm

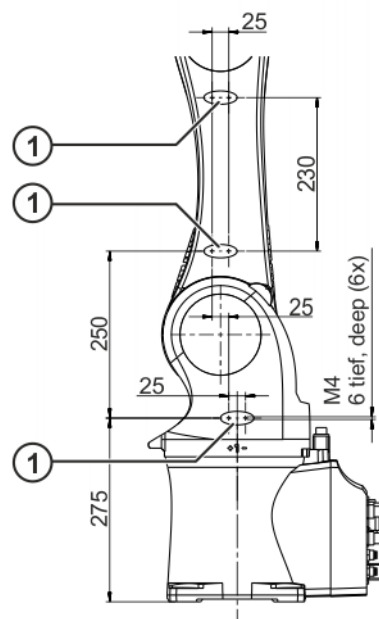

Fig. 4-26: Supplementary load on link arm and rotating column

- 1 Support bracket for supplementary load

The following figure (>>> Fig. 4-27) shows the dimensions and position of the installation options on the arm and in-line wrist for the following robots:

- KR 10 R1100 sixx
- KR 10 R1100 sixx W
- KR 10 R1100 sixx C

Maße / Dimensions: mm

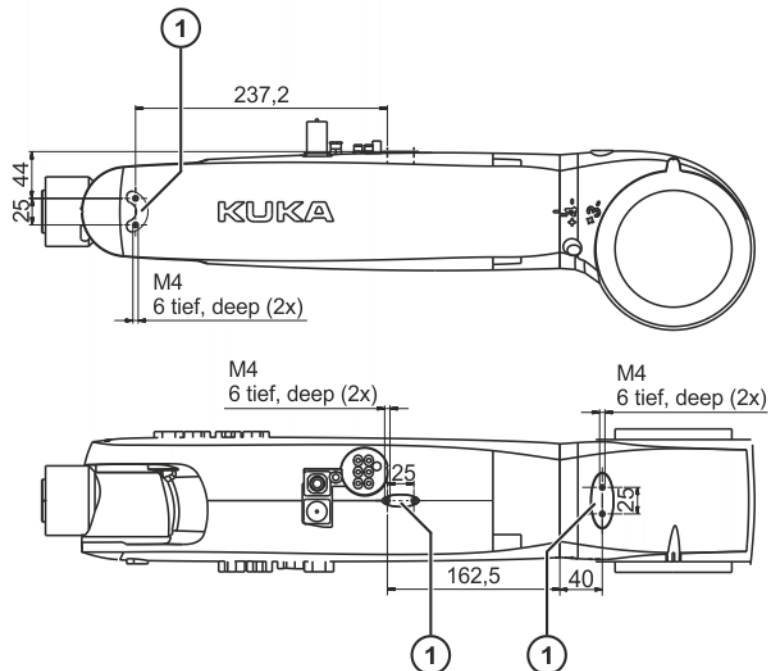

Fig. 4-27: Supplementary load on arm and in-line wrist

- 1 Support bracket for supplementary load

The following figure (>>> Fig. 4-28) shows the dimensions and position of the installation options on the link arm and rotating column for the following robots:

- KR 10 R1100 sixx
- KR 10 R1100 sixx W
- KR 10 R1100 sixx C

Maße / Dimensions: mm

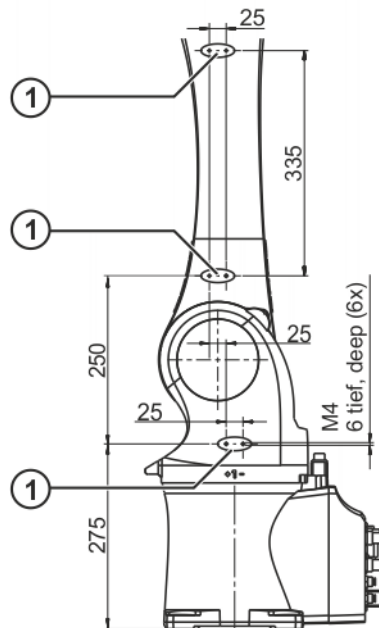

Fig. 4-28: Supplementary load on link arm and rotating column

- 1 Support bracket for supplementary load

4.8 Mounting base data, KR 10 sixx

Loads acting on the mounting base

The specified forces and moments already include the maximum payload and the inertia force (weight) of the robot.

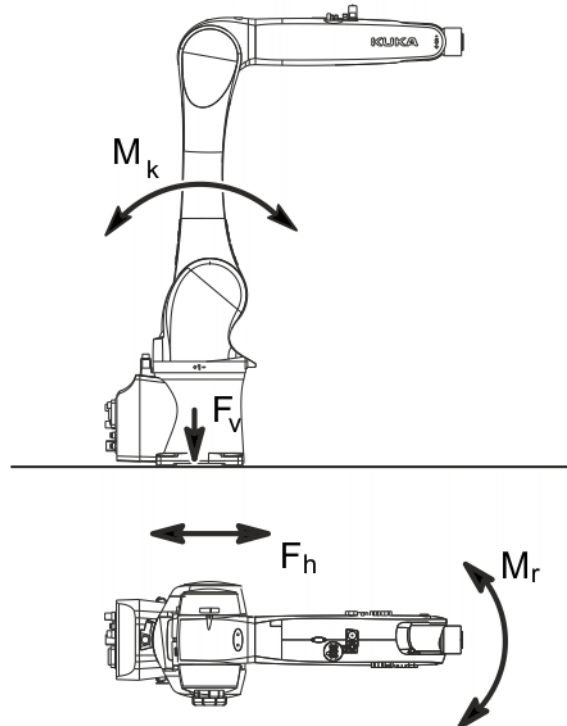

Fig. 4-29: Loads acting on the mounting base

Type of load	Force/torque/mass	
	Normal operation	Maximum load
F_v = vertical force	$F_{vmax} = 967 \text{ N}$	$F_{vmax} = 1297 \text{ N}$
F_h = horizontal force	$F_{hmax} = 1223 \text{ N}$	$F_{hmax} = 1362 \text{ N}$
M_k = tilting moment	$M_{kmax} = 788 \text{ Nm}$	$M_{kmax} = 1152 \text{ Nm}$
M_r = torque	$M_{rmax} = 367 \text{ Nm}$	$M_{rmax} = 880 \text{ Nm}$
Total mass for load acting on the mounting base	KR 10 R900 sixx: 62 kg KR 10 R1100 sixx: 65 kg	
Robot	KR 10 R900 sixx: 52 kg KR 10 R1100 sixx: 55 kg	
Total load for mounting base load (suppl. load on arm + rated payload)	KR 10 R900 sixx: 10 kg KR 10 R1100 sixx: 10 kg	

NOTICE

The foundation loads specified in the table are the maximum loads that may occur. They must be referred to when dimensioning the foundations and must be adhered to for safety reasons. Failure to do so may result in material damage. The supplementary loads are not taken into consideration in the calculation of the foundation load. These supplementary loads must be taken into consideration for F_v .

4.9 Plates and labels

Plates and labels The following plates and labels are attached to the robot. They must not be removed or rendered illegible. Illegible plates and labels must be replaced.

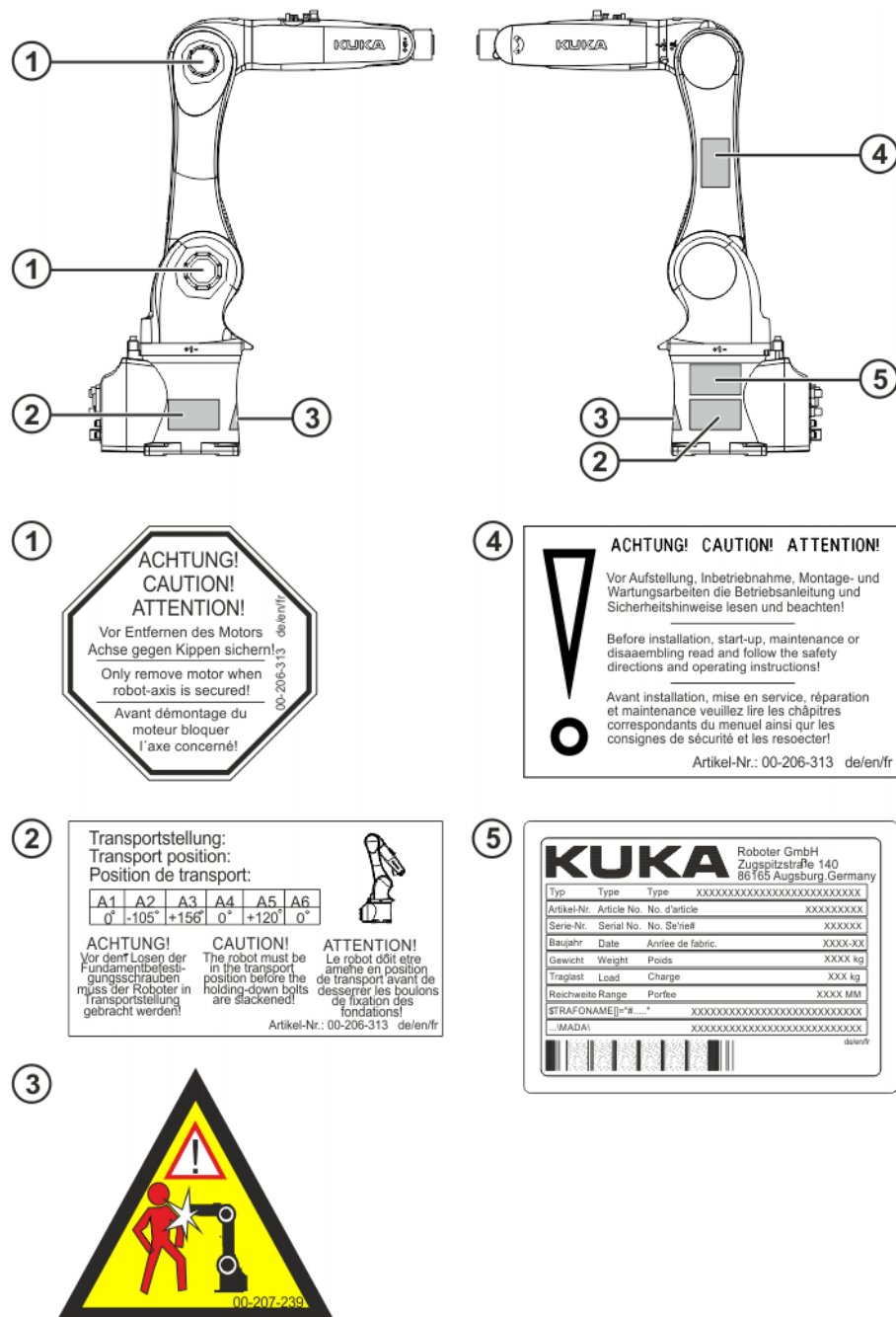

Fig. 4-30: Plates and labels

4.10 Stopping distances and times

4.10.1 General information

Information concerning the data:

- The stopping distance is the angle traveled by the robot from the moment the stop signal is triggered until the robot comes to a complete standstill.
- The stopping time is the time that elapses from the moment the stop signal is triggered until the robot comes to a complete standstill.
- The data are given for the main axes A1, A2 and A3. The main axes are the axes with the greatest deflection.
- Superposed axis motions can result in longer stopping distances.

- Stopping distances and stopping times in accordance with DIN EN ISO 10218-1, Annex B.
- Stop categories:
 - Stop category 0 » STOP 0
 - Stop category 1 » STOP 1 according to IEC 60204-1
- The values specified for Stop 0 are guide values determined by means of tests and simulation. They are average values which conform to the requirements of DIN EN ISO 10218-1. The actual stopping distances and stopping times may differ due to internal and external influences on the braking torque. It is therefore advisable to determine the exact stopping distances and stopping times where necessary under the real conditions of the actual robot application.
- Measuring technique
The stopping distances were measured using the robot-internal measuring technique.
- The wear on the brakes varies depending on the operating mode, robot application and the number of STOP 0 triggered. It is therefore advisable to check the stopping distance at least once a year.

4.10.2 Terms used

Term	Description
m	Mass of the rated load and the supplementary load on the arm.
Phi	Angle of rotation (°) about the corresponding axis. This value can be entered in the controller via the KCP and is displayed on the KCP.
POV	Program override (%) = velocity of the robot motion. This value can be entered in the controller via the KCP and is displayed on the KCP.
Extension	Distance (l in %) (>>> Fig. 4-31) between axis 1 and the intersection of axes 4 and 5. With parallelogram robots, the distance between axis 1 and the intersection of axis 6 and the mounting flange.
KCP	The KCP teach pendant has all the operator control and display functions required for operating and programming the robot system.

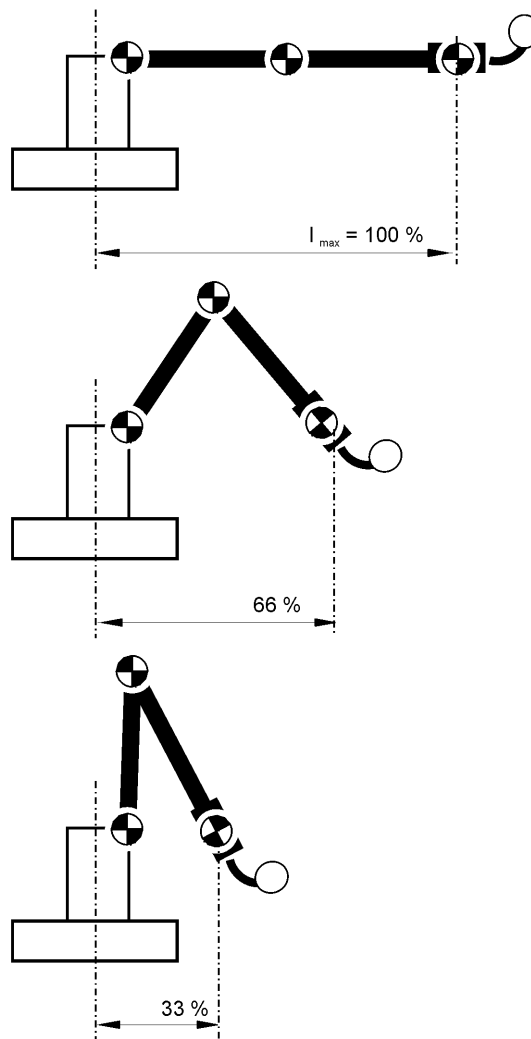

Fig. 4-31: Extension

4.10.3 Stopping distances and times, KR 6 R700 sixx and KR 6 R700 sixx C

The following values are preliminary values and are valid for the following robots.

- KR 6 R700 sixx
- KR 6 R700 sixx C

4.10.3.1 Stopping distances and stopping times for STOP 0, axis 1 to axis 3

The table shows the stopping distances and stopping times after a STOP 0 (category 0 stop) is triggered. The values refer to the following configuration:

- Extension $l = 100\%$
- Program override POV = 100%
- Mass $m =$ maximum load (rated load + supplementary load on arm)

	Stopping distance (°)	Stopping time (s)
Axis 1	133.67	0.494
Axis 2	122.43	0.556
Axis 3	79.29	0.371

4.10.3.2 Stopping distances and stopping times for STOP 1, axis 1

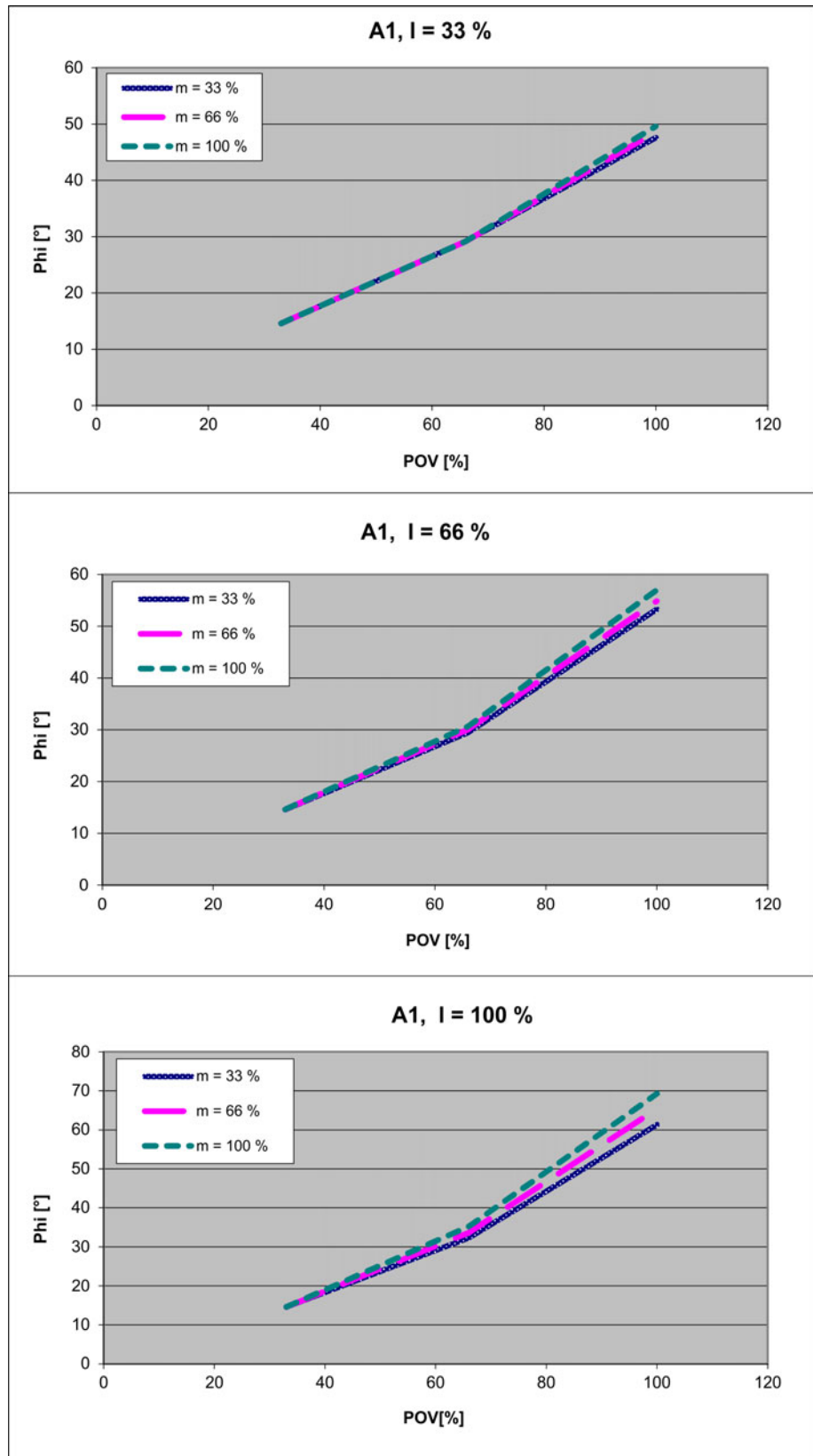

Fig. 4-32: Stopping distances for STOP 1, axis 1

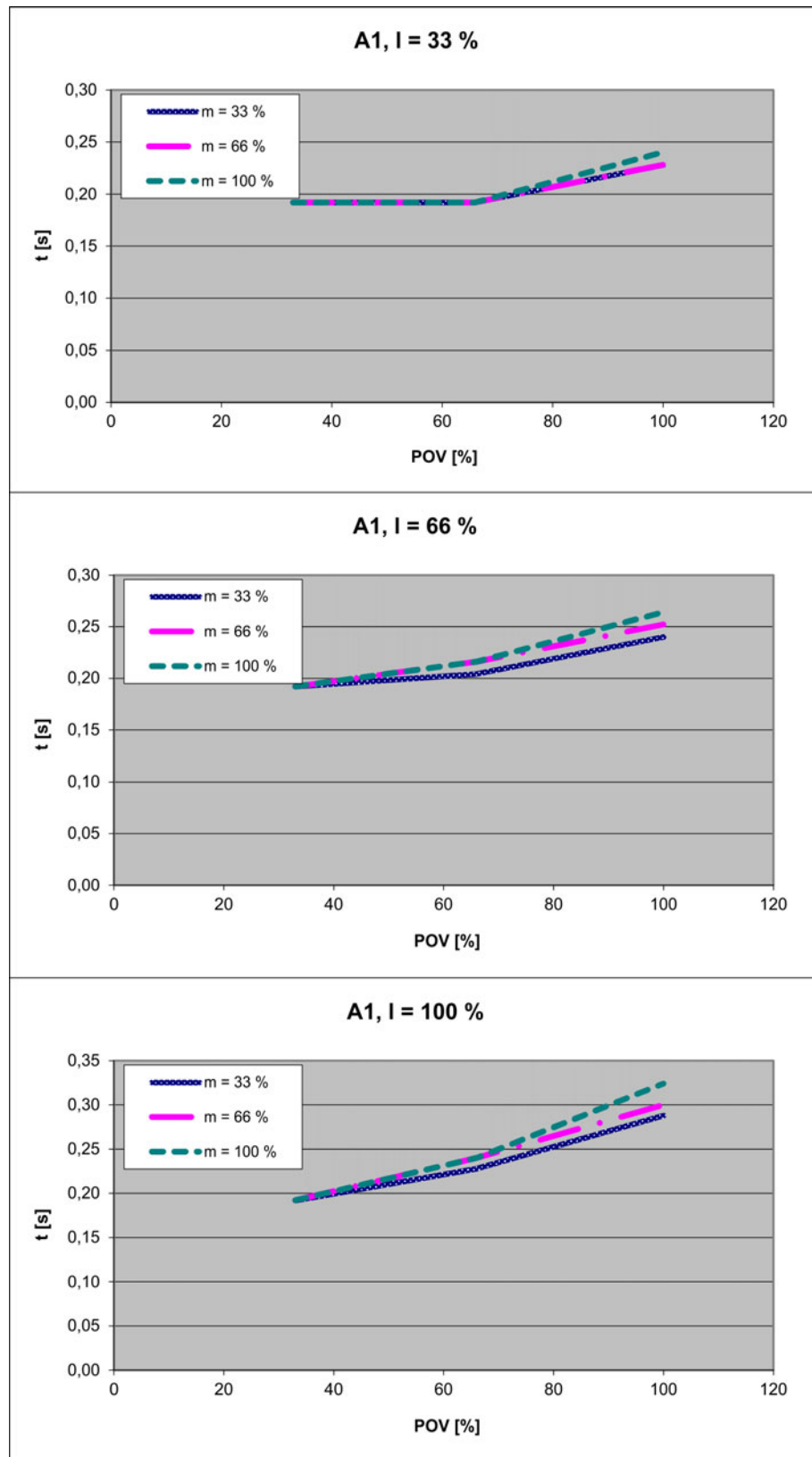

Fig. 4-33: Stopping times for STOP 1, axis 1

4.10.3.3 Stopping distances and stopping times for STOP 1, axis 2

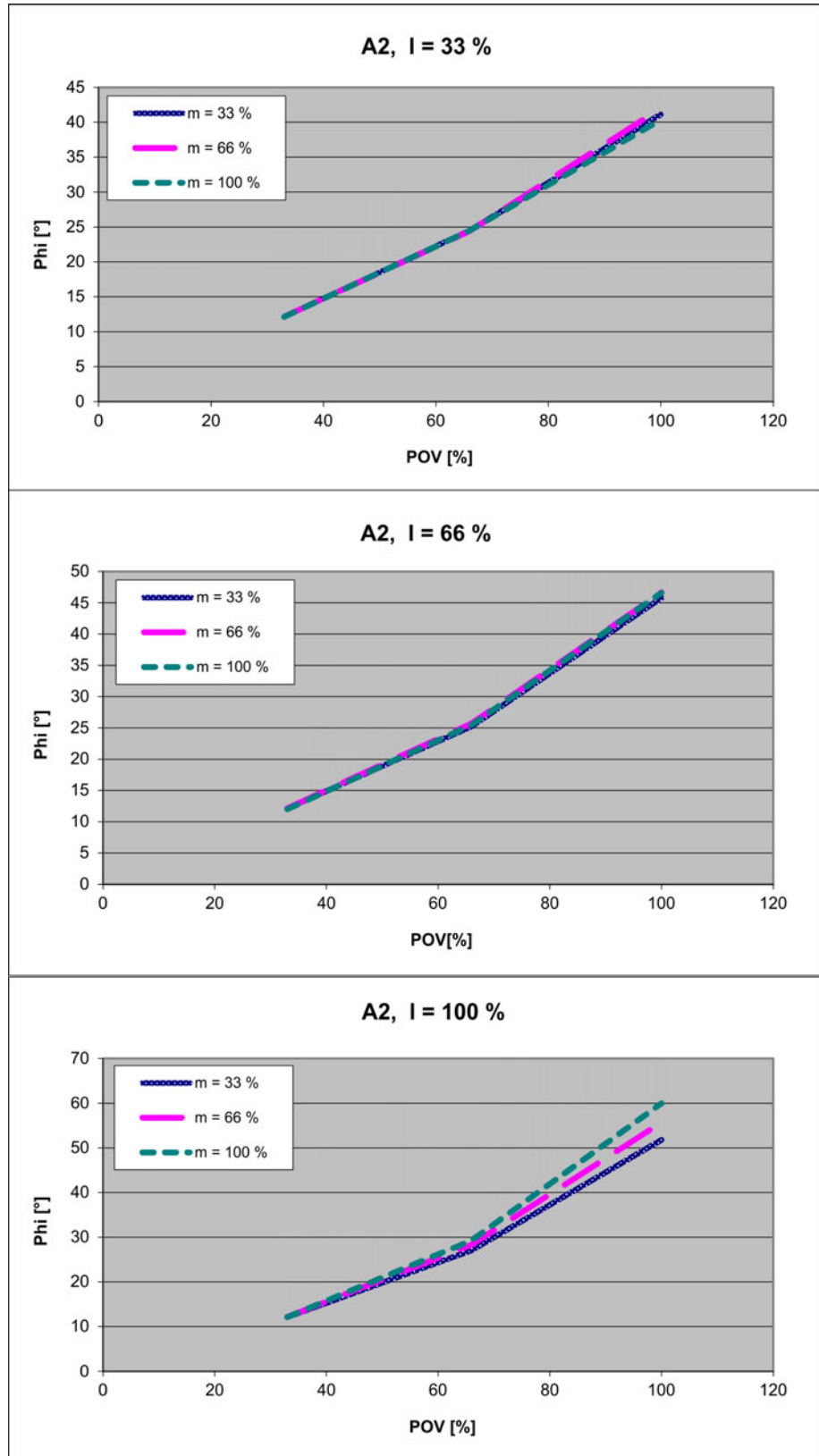

Fig. 4-34: Stopping distances for STOP 1, axis 2

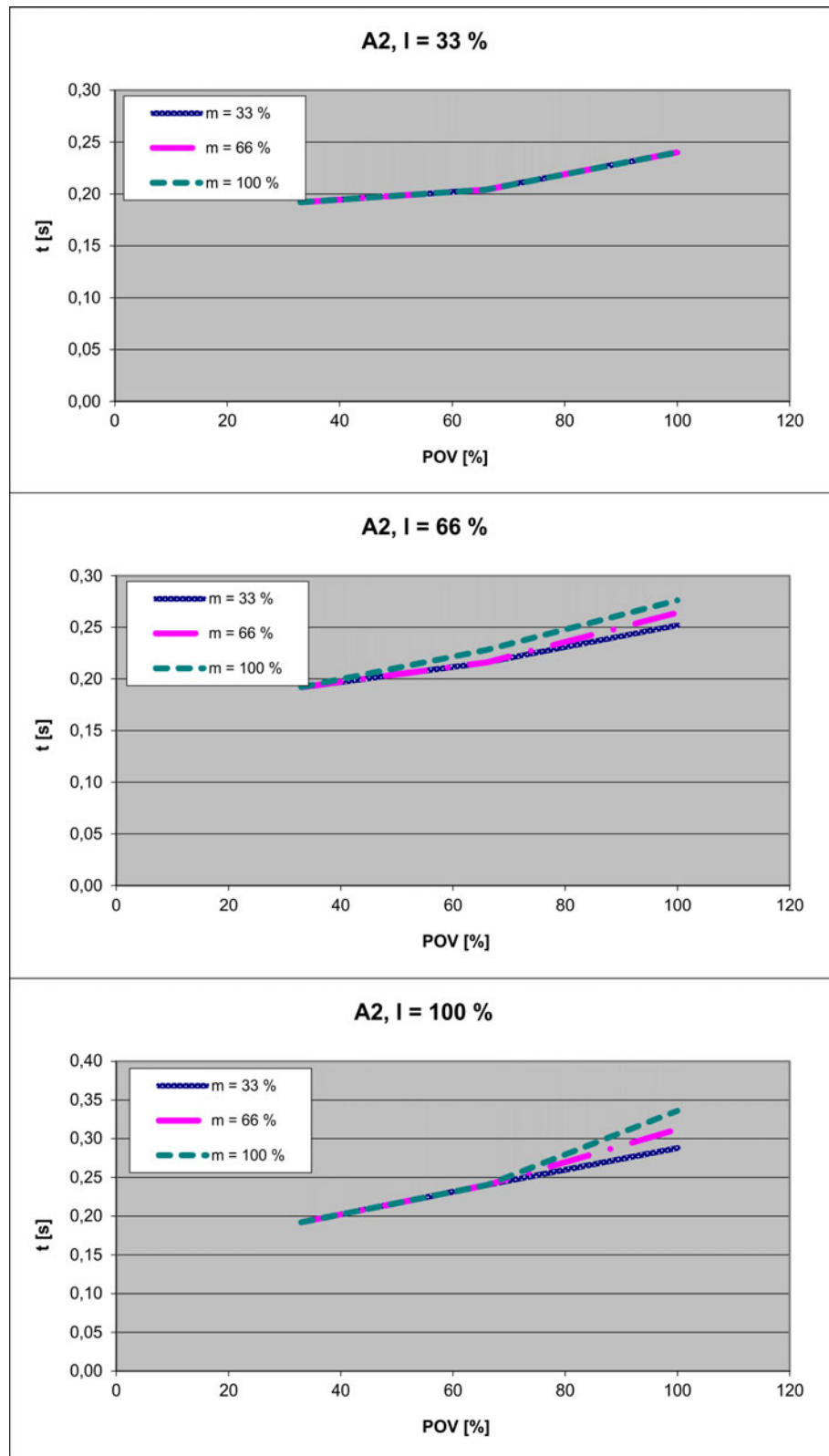

Fig. 4-35: Stopping times for STOP 1, axis 2

4.10.3.4 Stopping distances and stopping times for STOP 1, axis 3

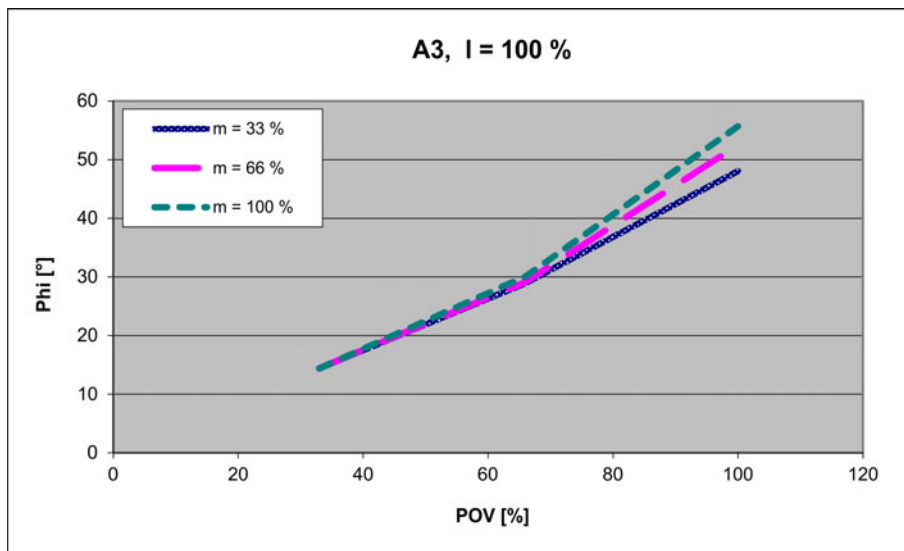

Fig. 4-36: Stopping distances for STOP 1, axis 3

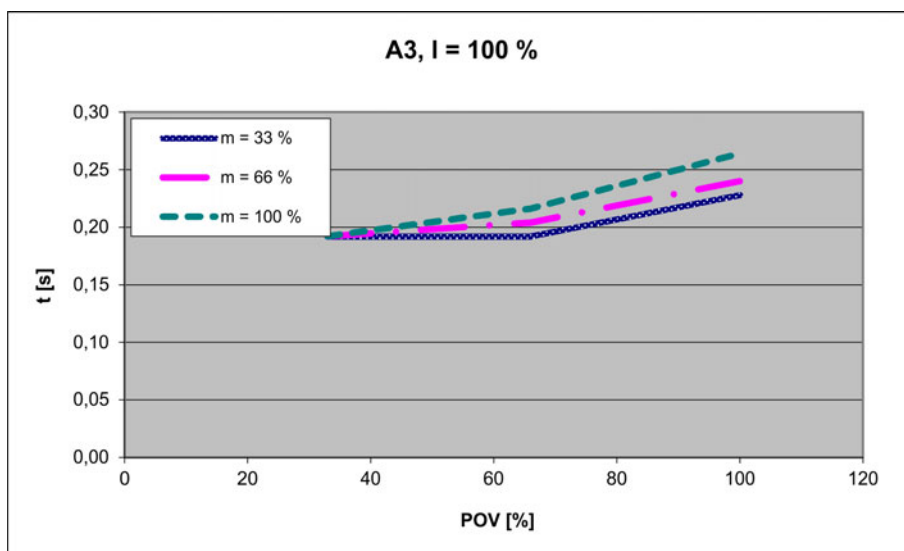

Fig. 4-37: Stopping times for STOP 1, axis 3

4.10.4 Stopping distances and times, KR 6 R700 sixx W

The following values are preliminary values and are valid for the following robots.

- KR 6 R700 sixx W

4.10.4.1 Stopping distances and stopping times for STOP 0, axis 1 to axis 3

The table shows the stopping distances and stopping times after a STOP 0 (category 0 stop) is triggered. The values refer to the following configuration:

- Extension I = 100%
- Program override POV = 100%
- Mass m = maximum load (rated load + supplementary load on arm)

	Stopping distance (°)	Stopping time (s)
Axis 1	182.04	0.665
Axis 2	68.31	0.377
Axis 3	63.48	0.379

4.10.4.2 Stopping distances and stopping times for STOP 1, axis 1

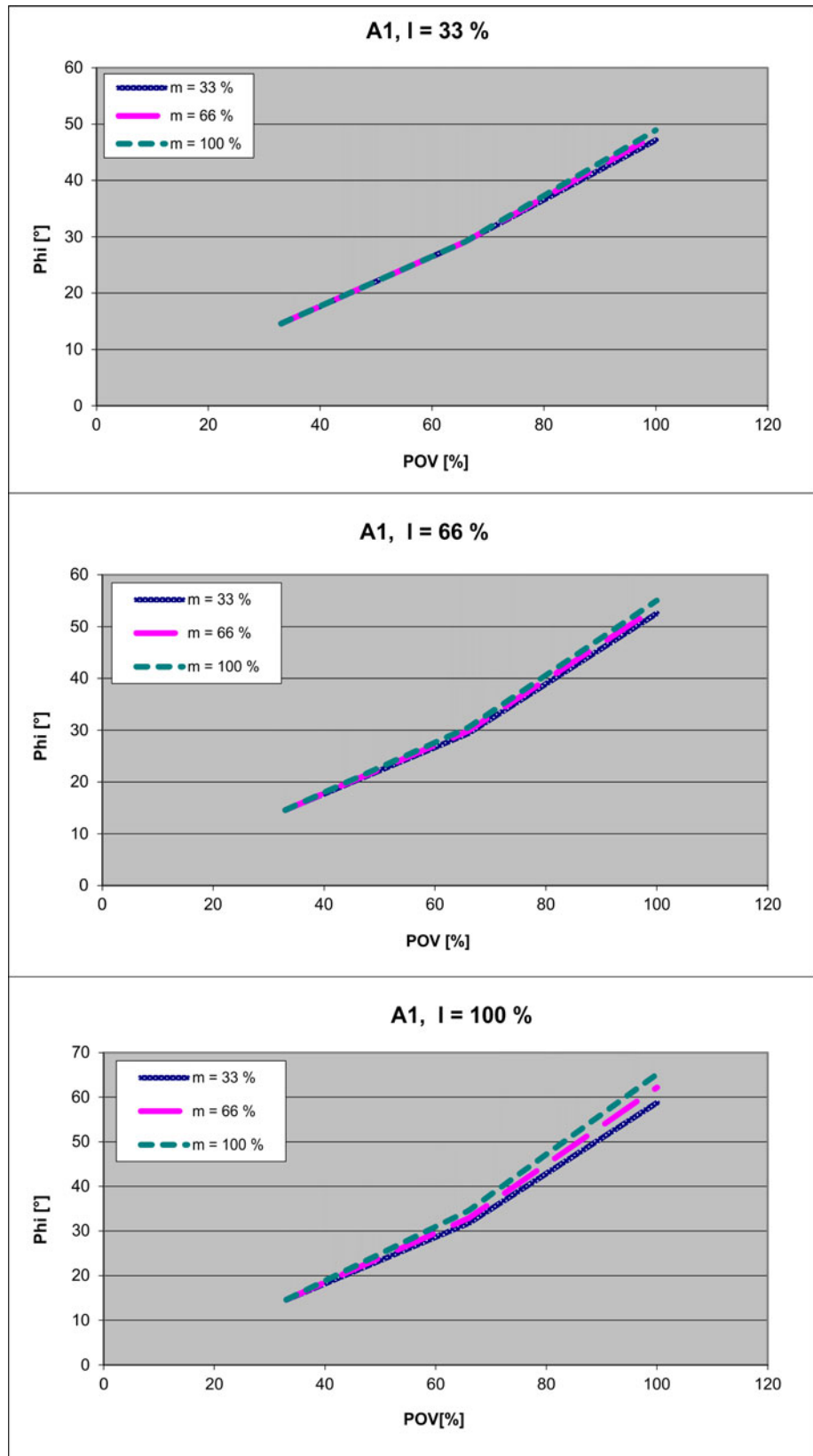

Fig. 4-38: Stopping distances for STOP 1, axis 1

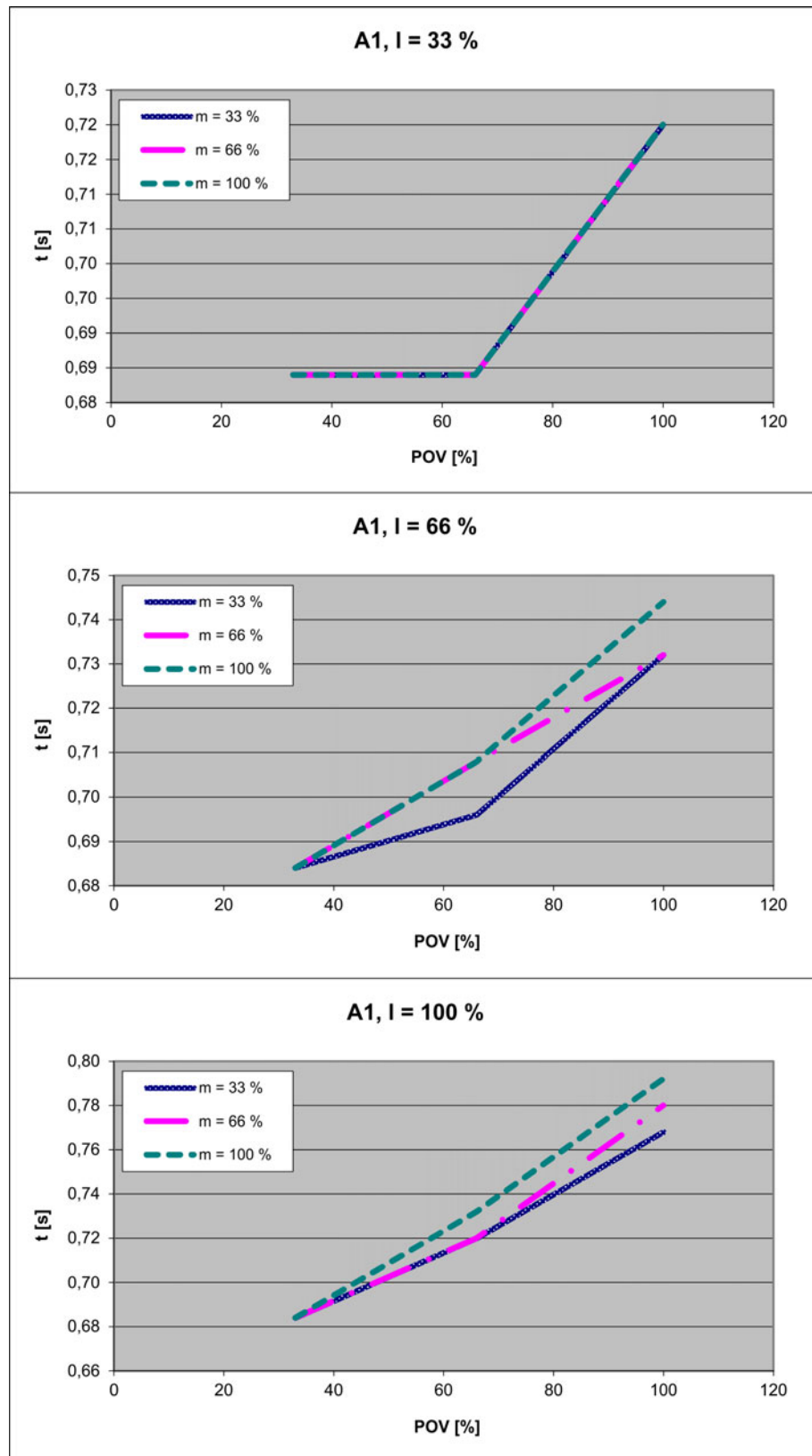

Fig. 4-39: Stopping times for STOP 1, axis 1

4.10.4.3 Stopping distances and stopping times for STOP 1, axis 2

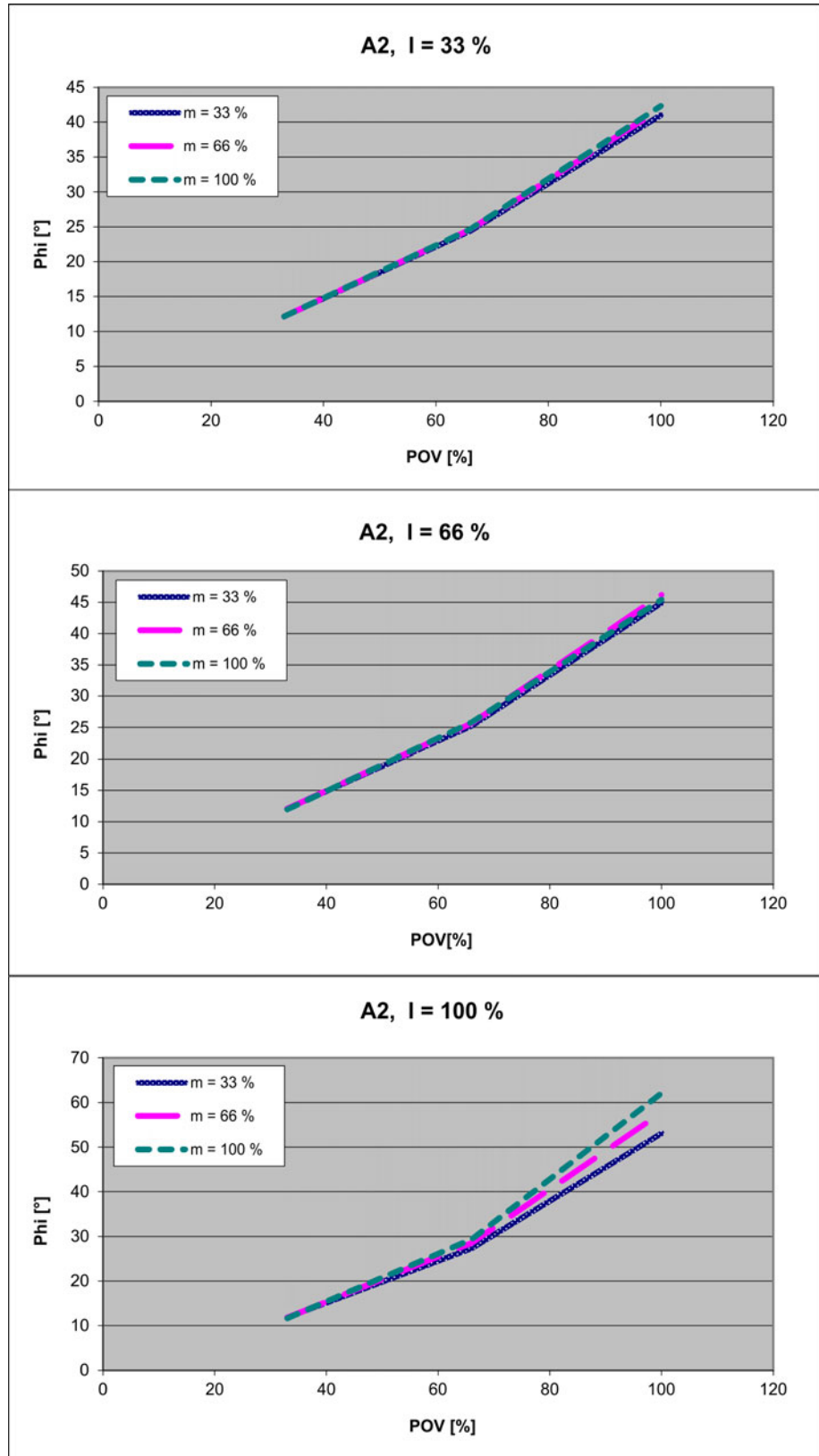

Fig. 4-40: Stopping distances for STOP 1, axis 1

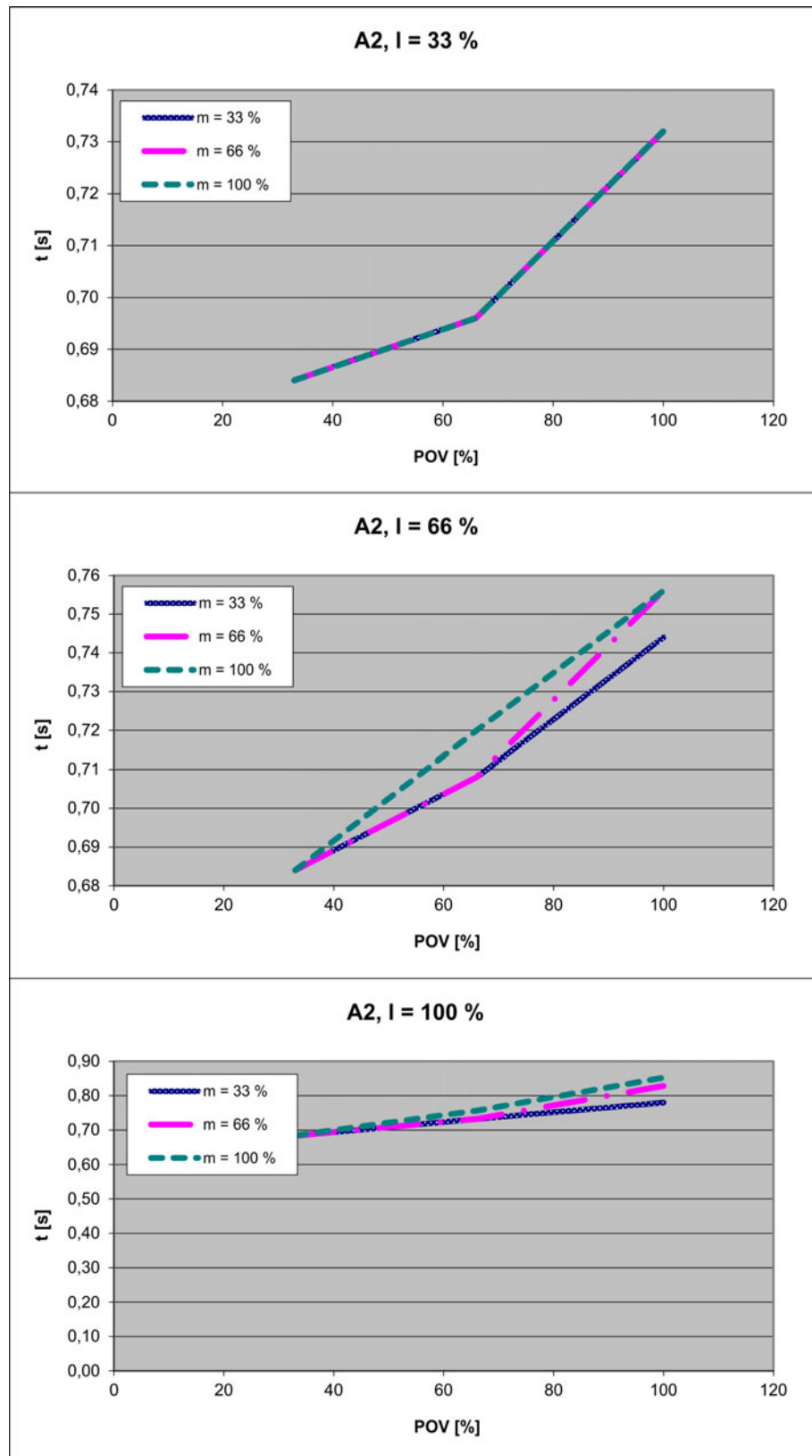

Fig. 4-41: Stopping times for STOP 1, axis 1

4.10.4.4 Stopping distances and stopping times for STOP 1, axis 2

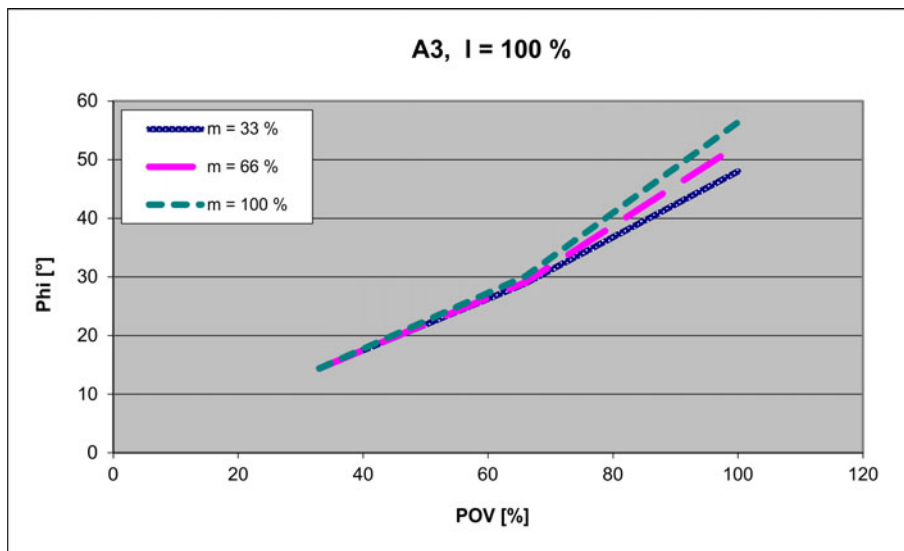

Fig. 4-42: Stopping distances for STOP 1, axis 1

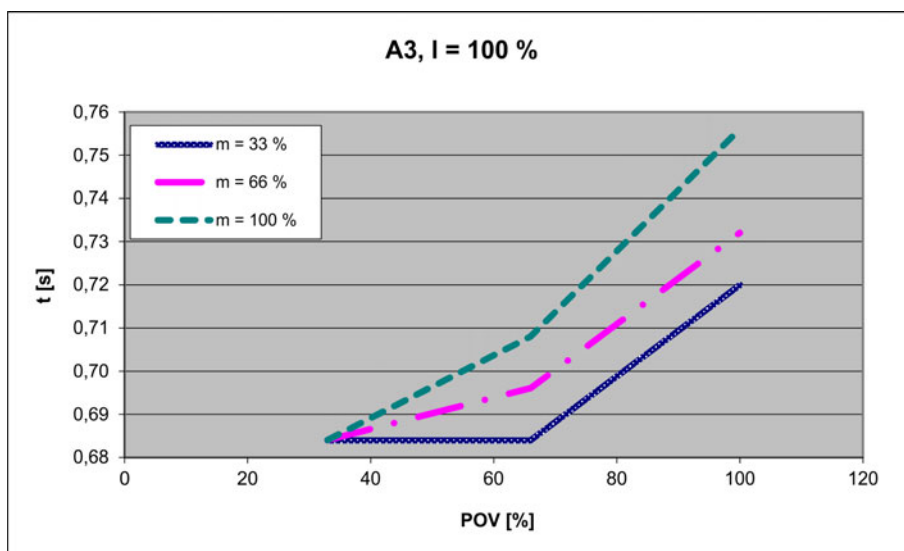

Fig. 4-43: Stopping times for STOP 1, axis 1

4.10.5 Stopping distances and times, KR 6 R900 sixx

The following values are valid for the following robots:

- KR 6 R900 sixx
- KR 6 R900 sixx C

4.10.5.1 Stopping distances and stopping times for STOP 0, axis 1 to axis 3

The table shows the stopping distances and stopping times after a STOP 0 (category 0 stop) is triggered. The values refer to the following configuration:

- Extension I = 100%
- Program override POV = 100%
- Mass m = maximum load (rated load + supplementary load on arm)

	Stopping distance (°)	Stopping time (s)
Axis 1	113.59	0.507
Axis 2	126.76	0.684
Axis 3	68.10	0.370

4.10.5.2 Stopping distances and stopping times for STOP 1, axis 1

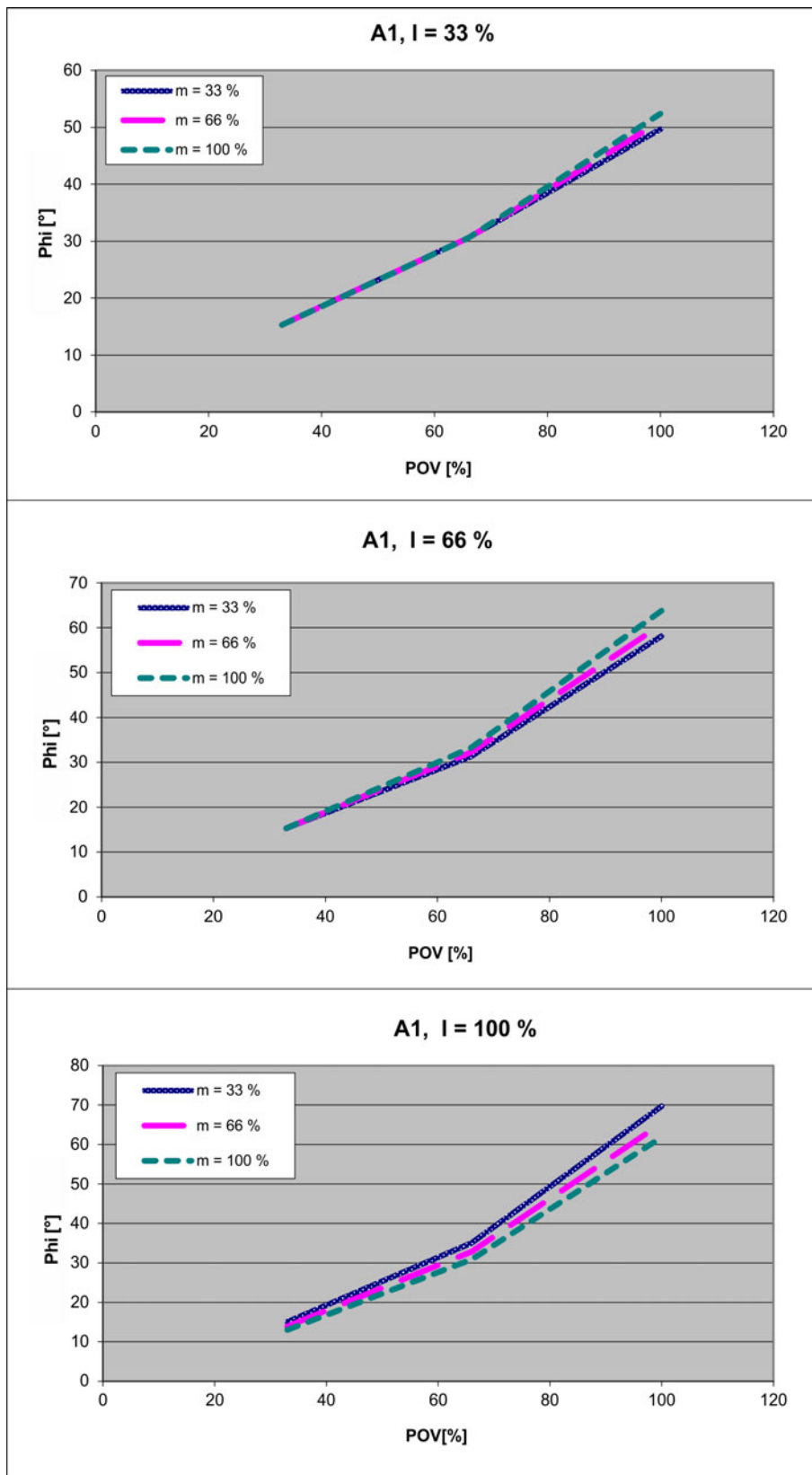

Fig. 4-44: Stopping distances for STOP 1, axis 1

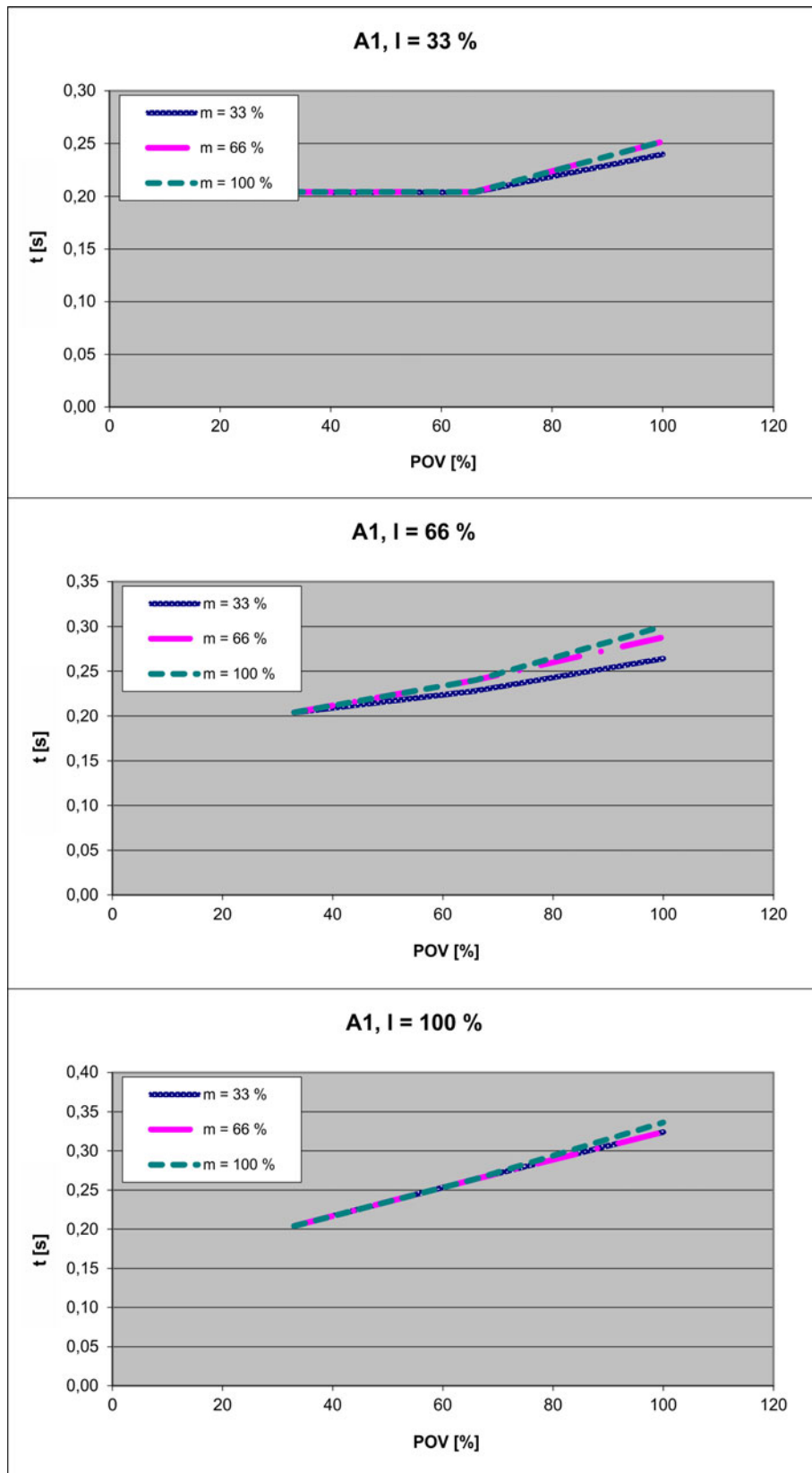

Fig. 4-45: Stopping times for STOP 1, axis 1

4.10.5.3 Stopping distances and stopping times for STOP 1, axis 2

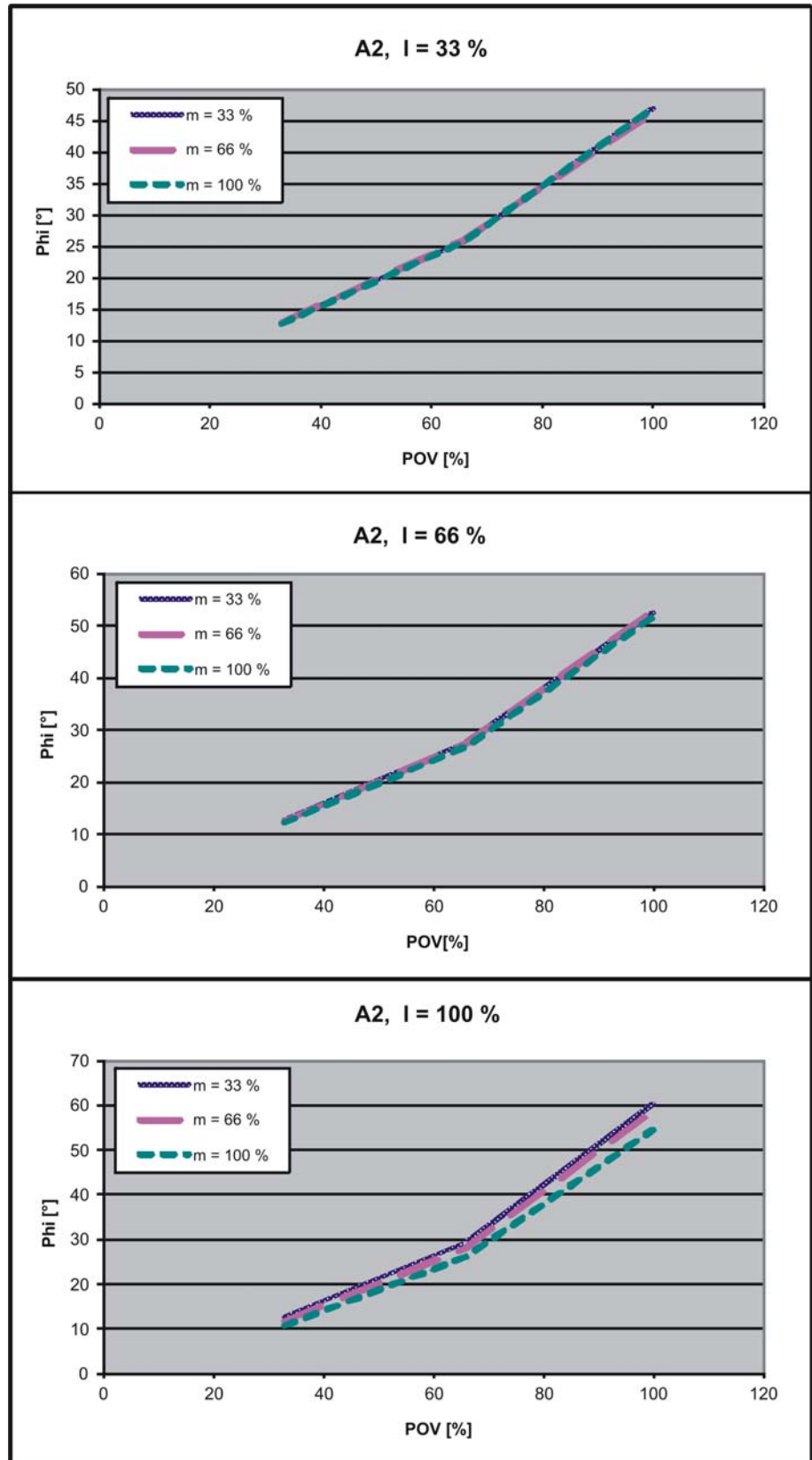

Fig. 4-46: Stopping distances for STOP 1, axis 2

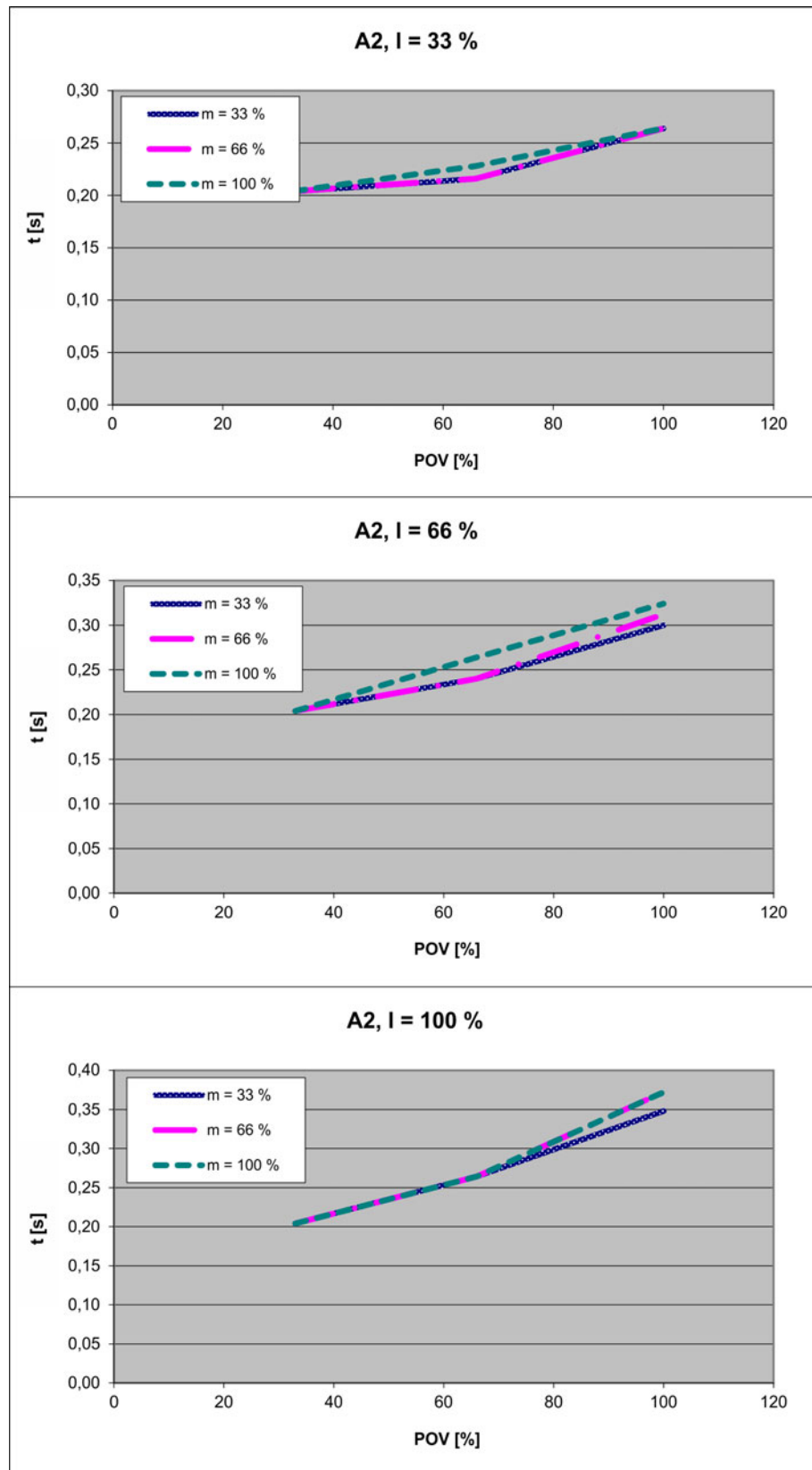

Fig. 4-47: Stopping times for STOP 1, axis 2

4.10.5.4 Stopping distances and stopping times for STOP 1, axis 3

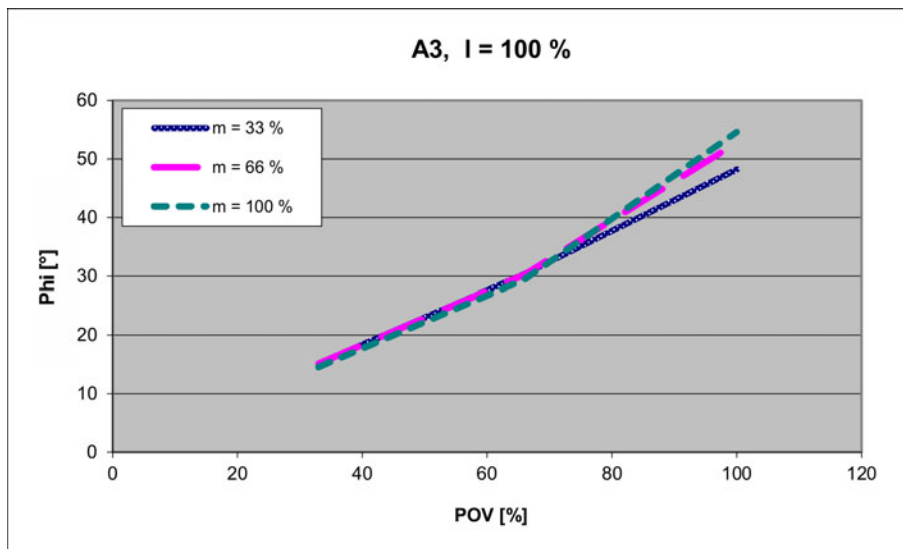

Fig. 4-48: Stopping distances for STOP 1, axis 3

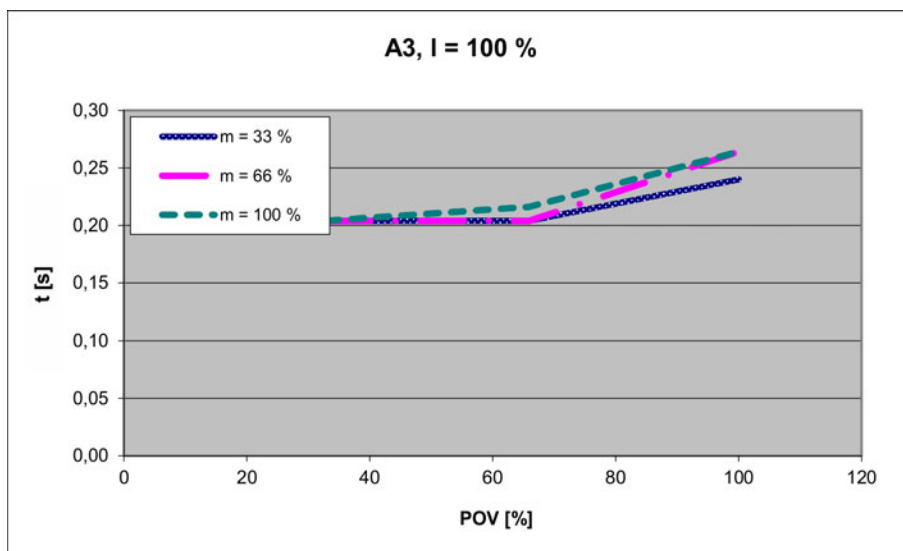

Fig. 4-49: Stopping times for STOP 1, axis 3

4.10.6 Stopping distances and times, KR 6 R900 sixx W

The following values are valid for the following robots:

- KR 6 R900 sixx W

4.10.6.1 Stopping distances and stopping times for STOP 0, axis 1 to axis 3

The table shows the stopping distances and stopping times after a STOP 0 (category 0 stop) is triggered. The values refer to the following configuration:

- Extension I = 100%
- Program override POV = 100%
- Mass m = maximum load (rated load + supplementary load on arm)

	Stopping distance (°)	Stopping time (s)
Axis 1	163.11	0.745
Axis 2	67.78	0.404
Axis 3	60.96	0.387

4.10.6.2 Stopping distances and stopping times for STOP 1, axis 1

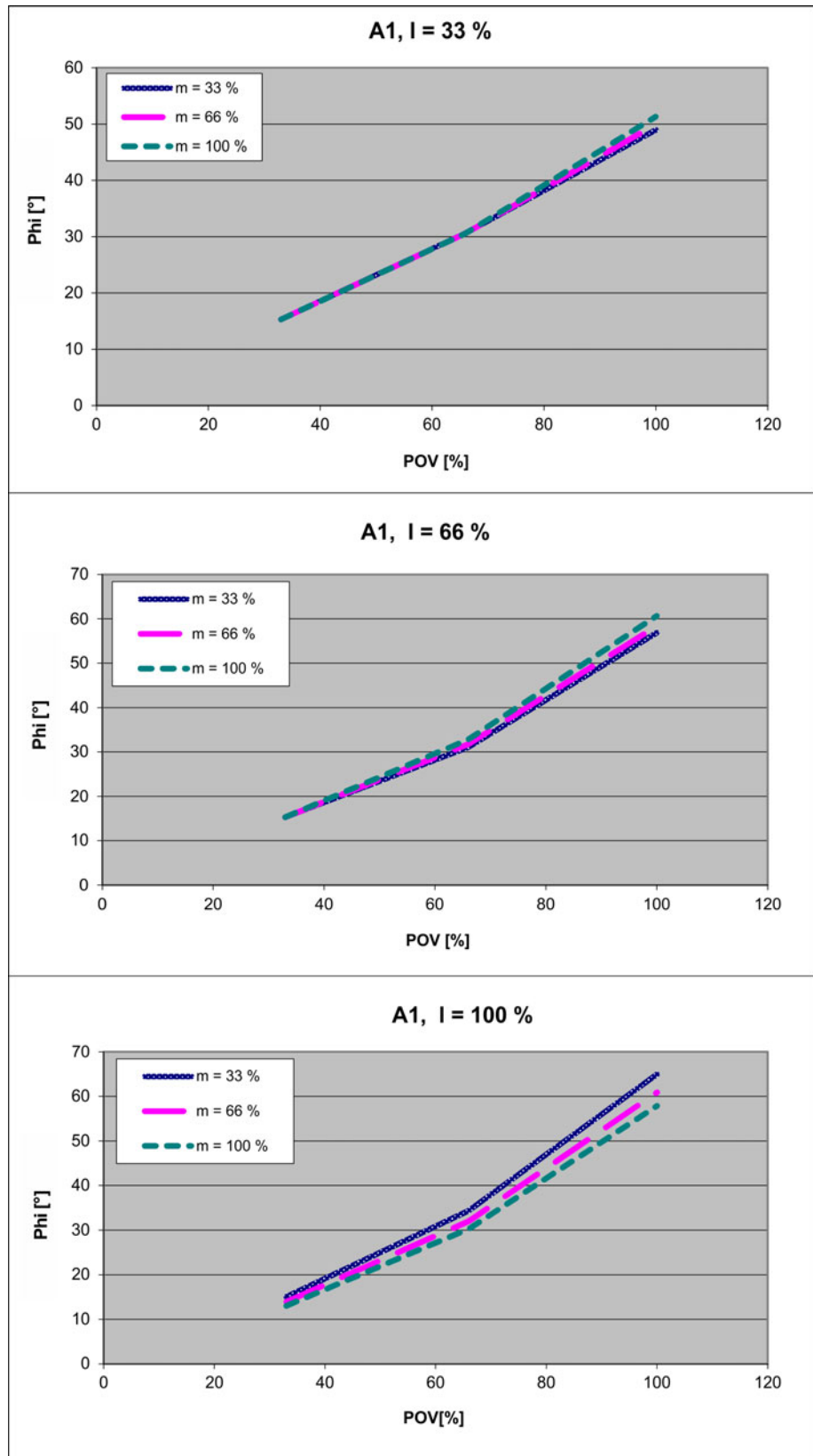

Fig. 4-50: Stopping distances for STOP 1, axis 1

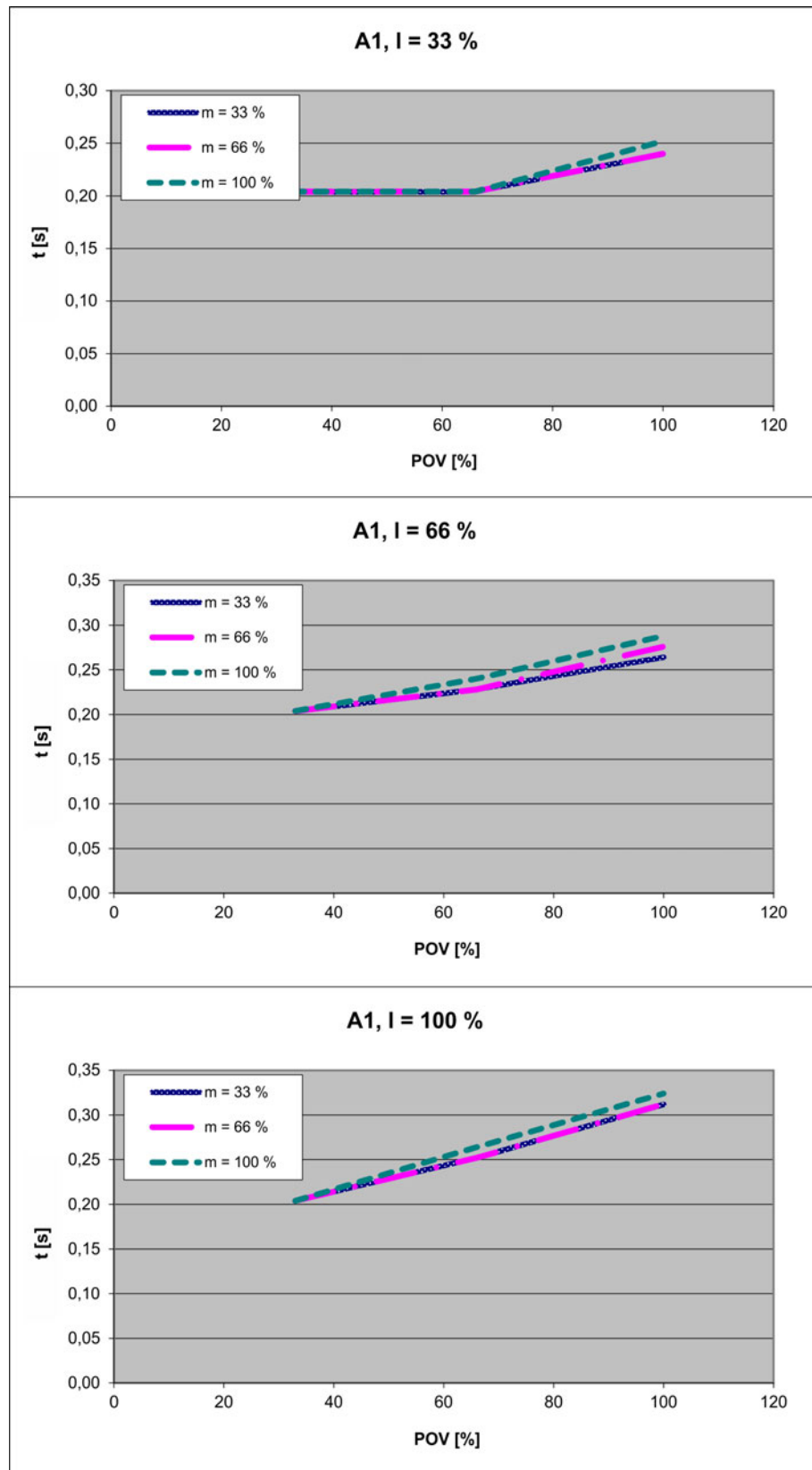

Fig. 4-51: Stopping times for STOP 1, axis 1

4.10.6.3 Stopping distances and stopping times for STOP 1, axis 2

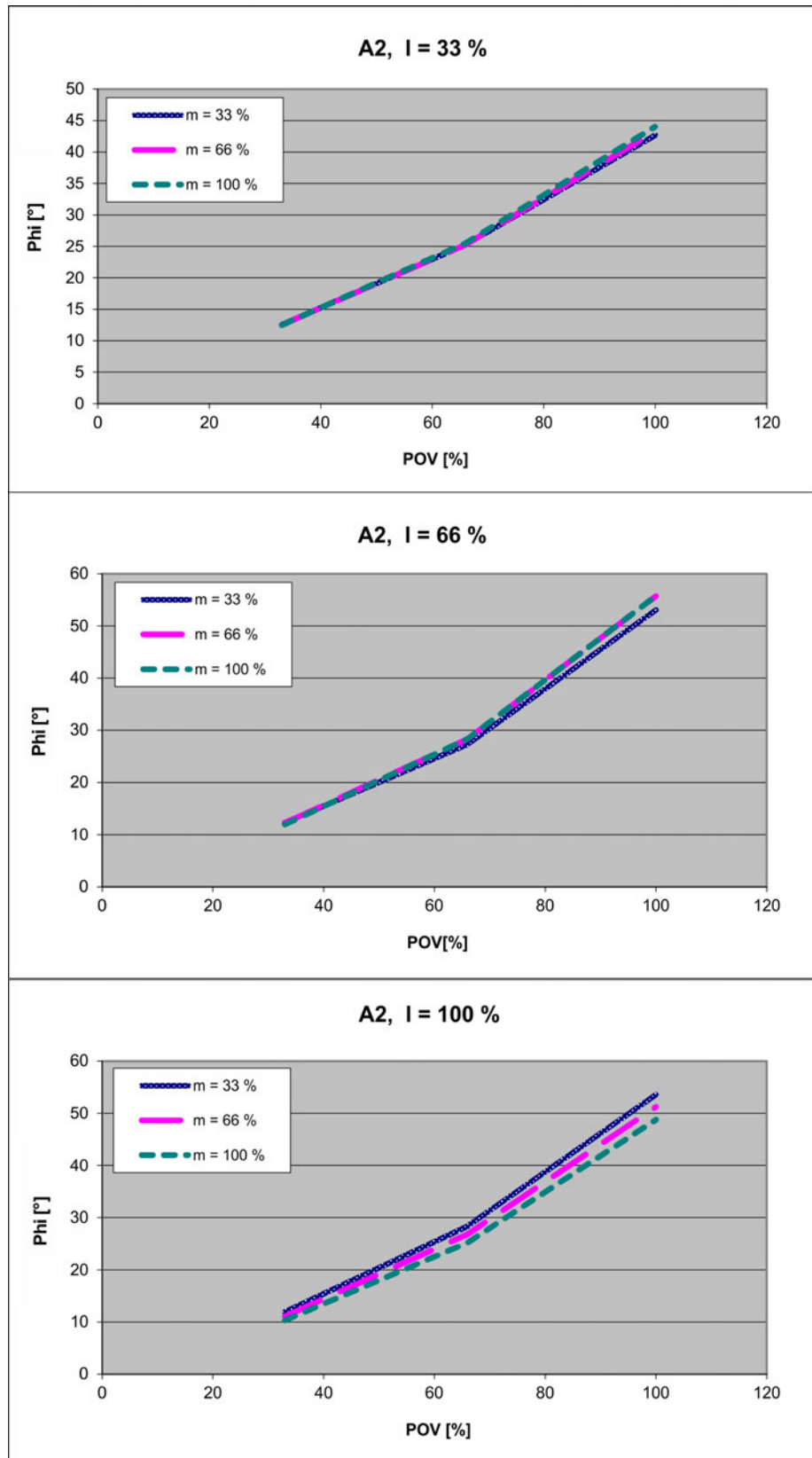

Fig. 4-52: Stopping distances for STOP 1, axis 2

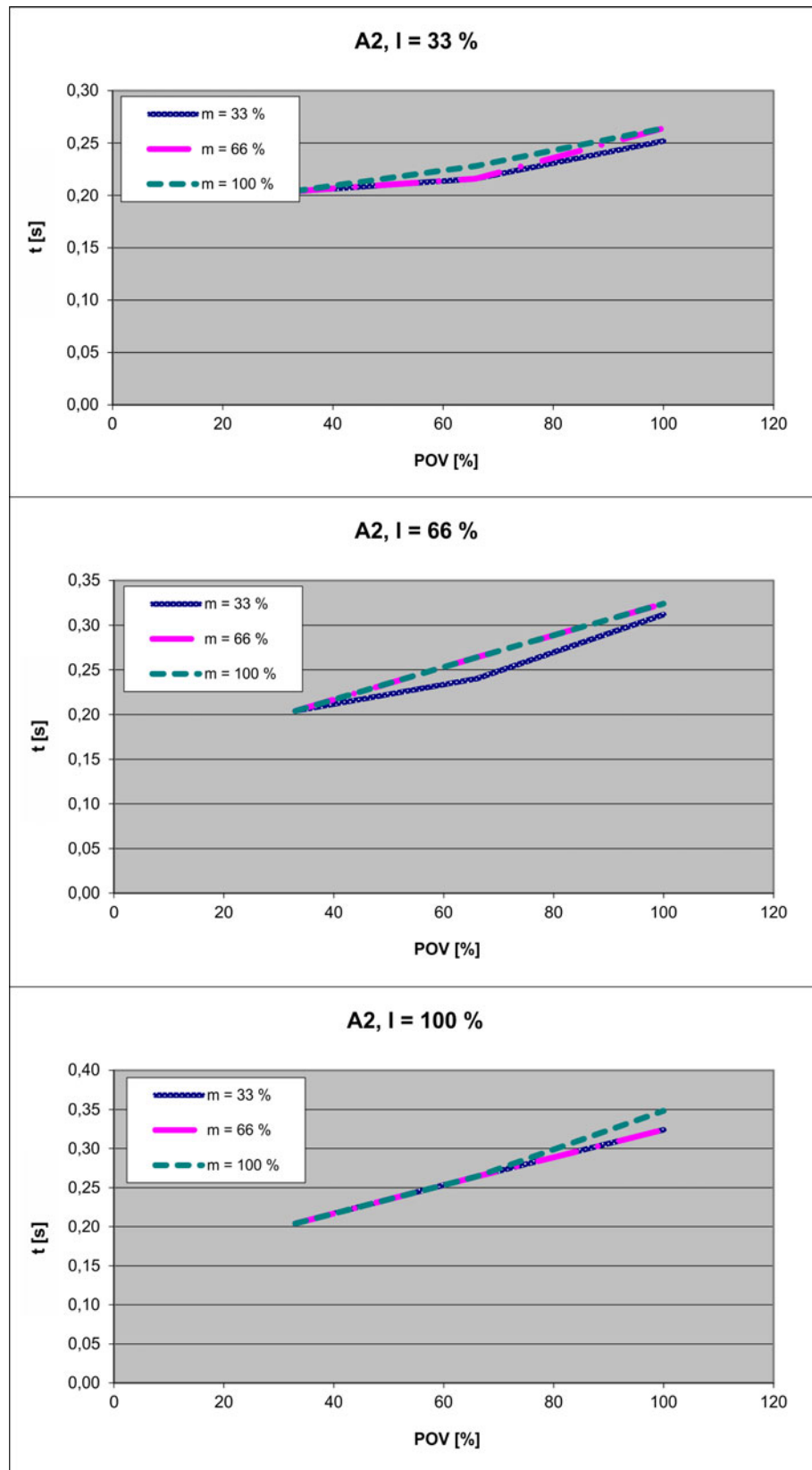

Fig. 4-53: Stopping times for STOP 1, axis 2

4.10.6.4 Stopping distances and stopping times for STOP 1, axis 3

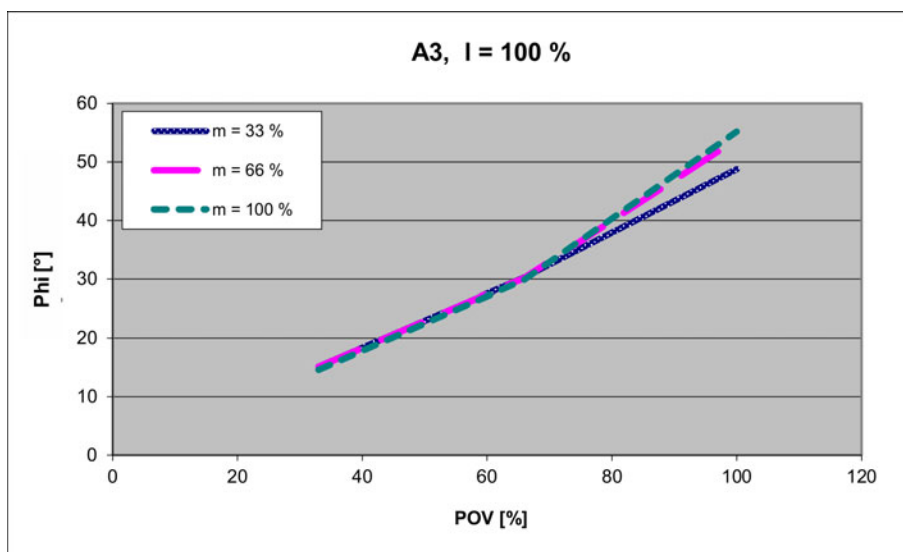

Fig. 4-54: Stopping distances for STOP 1, axis 3

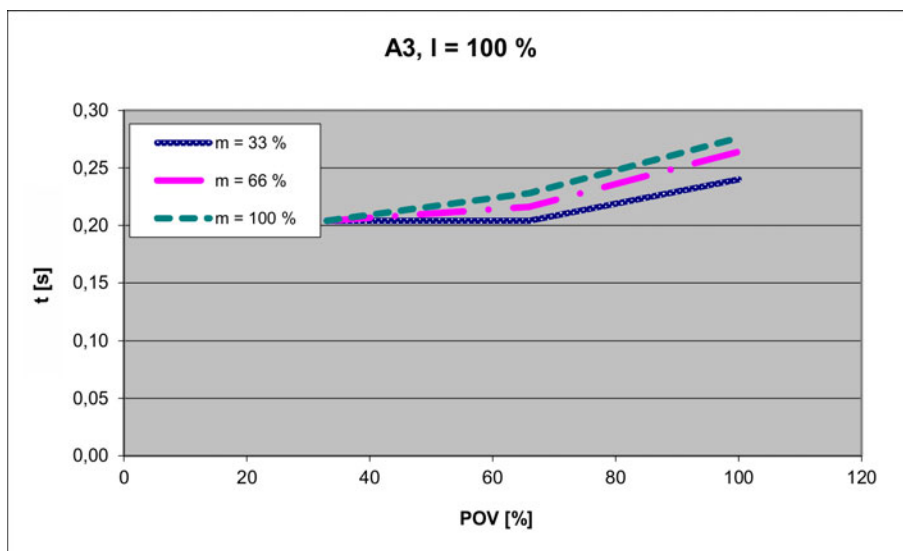

Fig. 4-55: Stopping times for STOP 1, axis 3

4.10.7 Stopping distances and times, KR 10 R900 sixx and KR 10 R1100 sixx

The following values are preliminary values and are valid for the following robots.

- KR 10 R900 sixx
- KR 10 R900 sixx C
- KR 10 R1100 sixx
- KR 10 R1100 sixx C

4.10.7.1 Stopping distances and stopping times for STOP 0, axis 1 to axis 3

The table shows the stopping distances and stopping times after a STOP 0 (category 0 stop) is triggered. The values refer to the following configuration:

- Extension I = 100%
- Program override POV = 100%

- Mass m = maximum load (rated load + supplementary load on arm)

	Stopping distance (°)	Stopping time (s)
Axis 1	106.21	0.536
Axis 2	96.06	0.647
Axis 3	46.99	0.373

4.10.7.2 Stopping distances and stopping times for STOP 1, axis 1

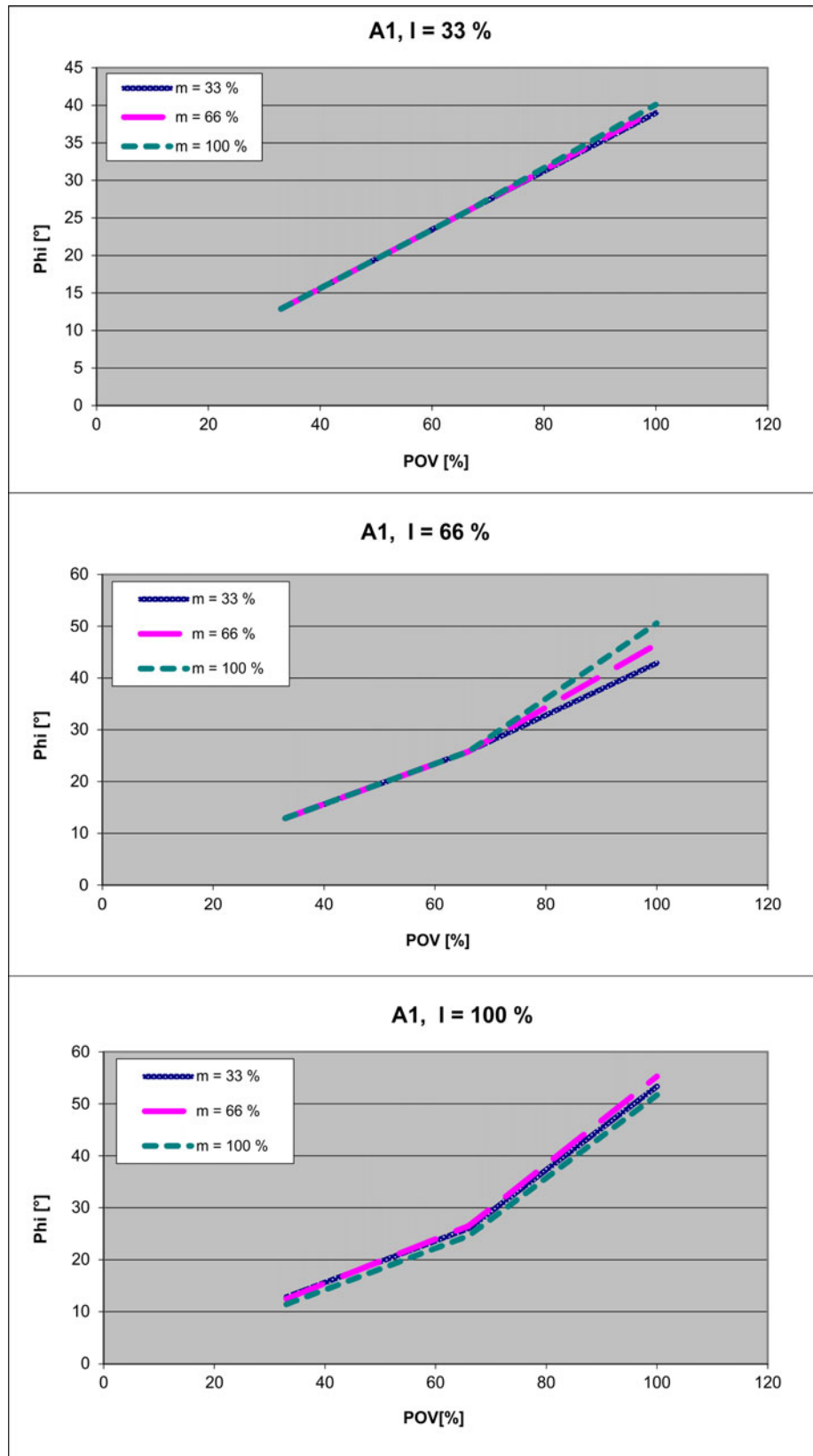

Fig. 4-56: Stopping distances for STOP 1, axis 1

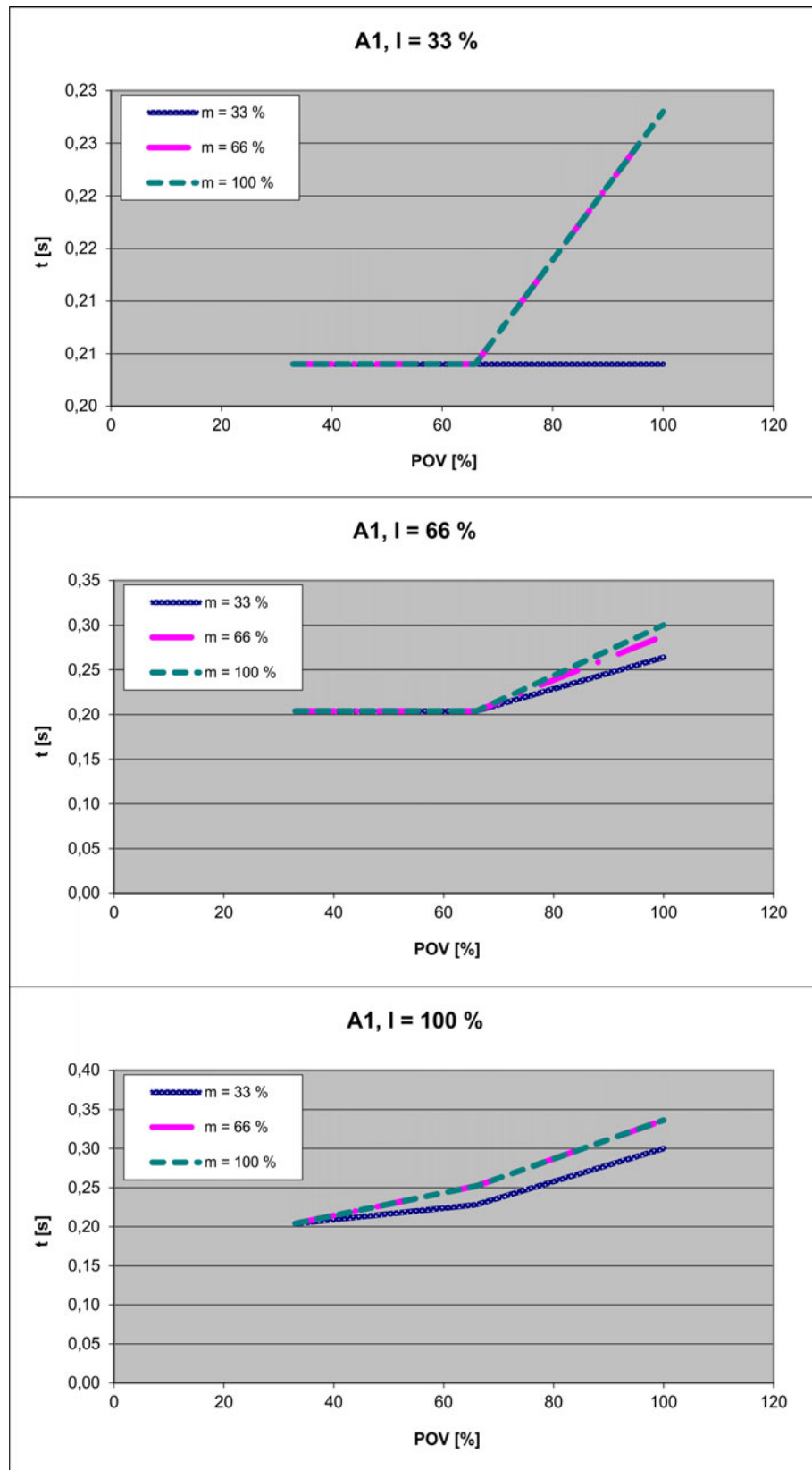

Fig. 4-57: Stopping times for STOP 1, axis 1

4.10.7.3 Stopping distances and stopping times for STOP 1, axis 2

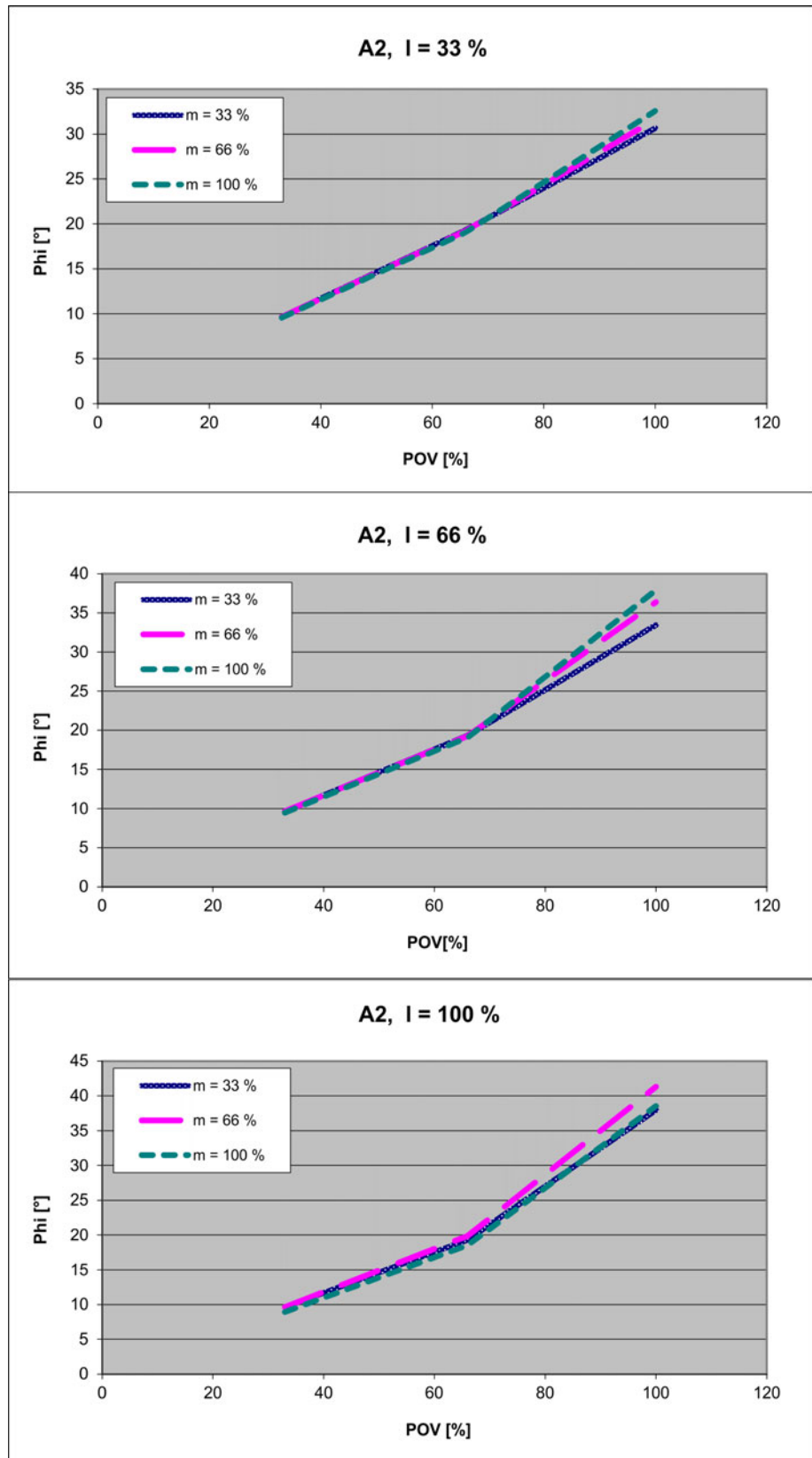

Fig. 4-58: Stopping distances for STOP 1, axis 2

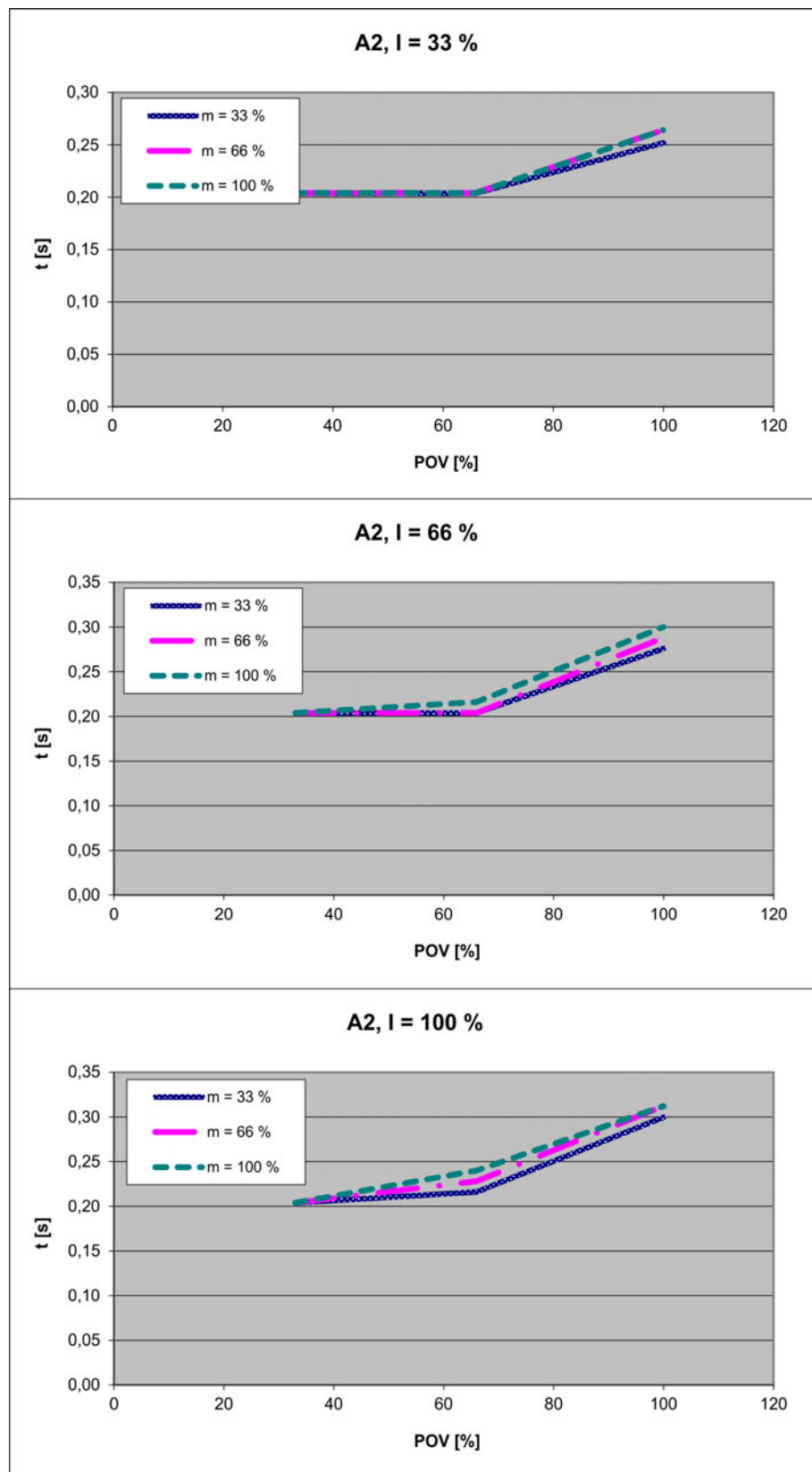

Fig. 4-59: Stopping times for STOP 1, axis 2

4.10.7.4 Stopping distances and stopping times for STOP 1, axis 3

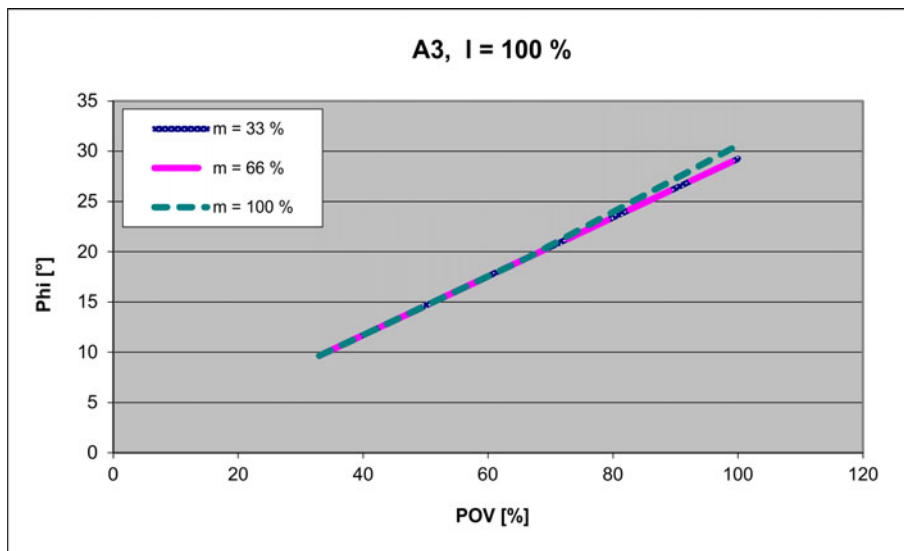

Fig. 4-60: Stopping distances for STOP 1, axis 3

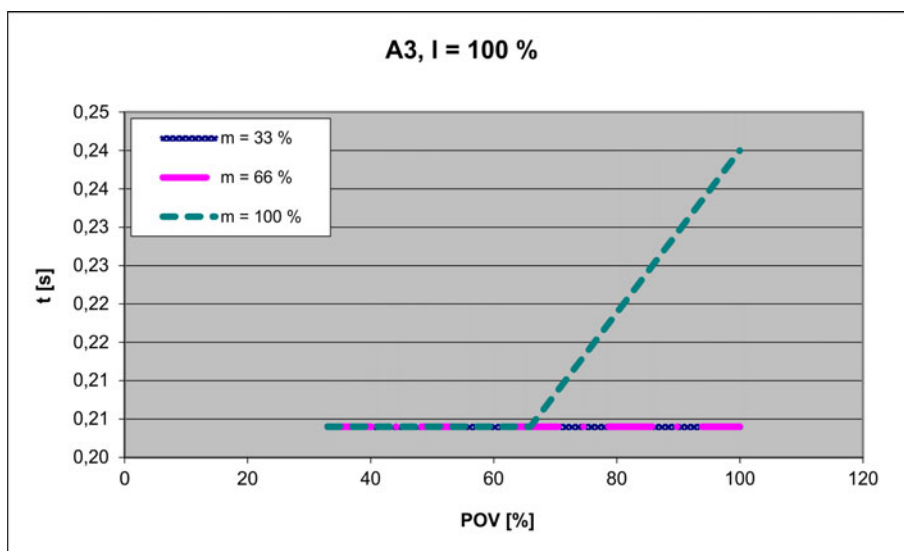

Fig. 4-61: Stopping times for STOP 1, axis 3

4.10.8 Stopping distances and times, KR 10 R900 sixx W and KR 10 R1100 sixx W

The following values are preliminary values and are valid for the following robots.

- KR 10 R900 sixx W
- KR 10 R1100 sixx W

4.10.8.1 Stopping distances and stopping times for STOP 0, axis 1 to axis 3

The table shows the stopping distances and stopping times after a STOP 0 (category 0 stop) is triggered. The values refer to the following configuration:

- Extension I = 100%
- Program override POV = 100%
- Mass m = maximum load (rated load + supplementary load on arm)

	Stopping distance (°)	Stopping time (s)
Axis 1	163.11	0.745
Axis 2	67.78	0.404
Axis 3	60.96	0.387

4.10.8.2 Stopping distances and stopping times for STOP 1, axis 1

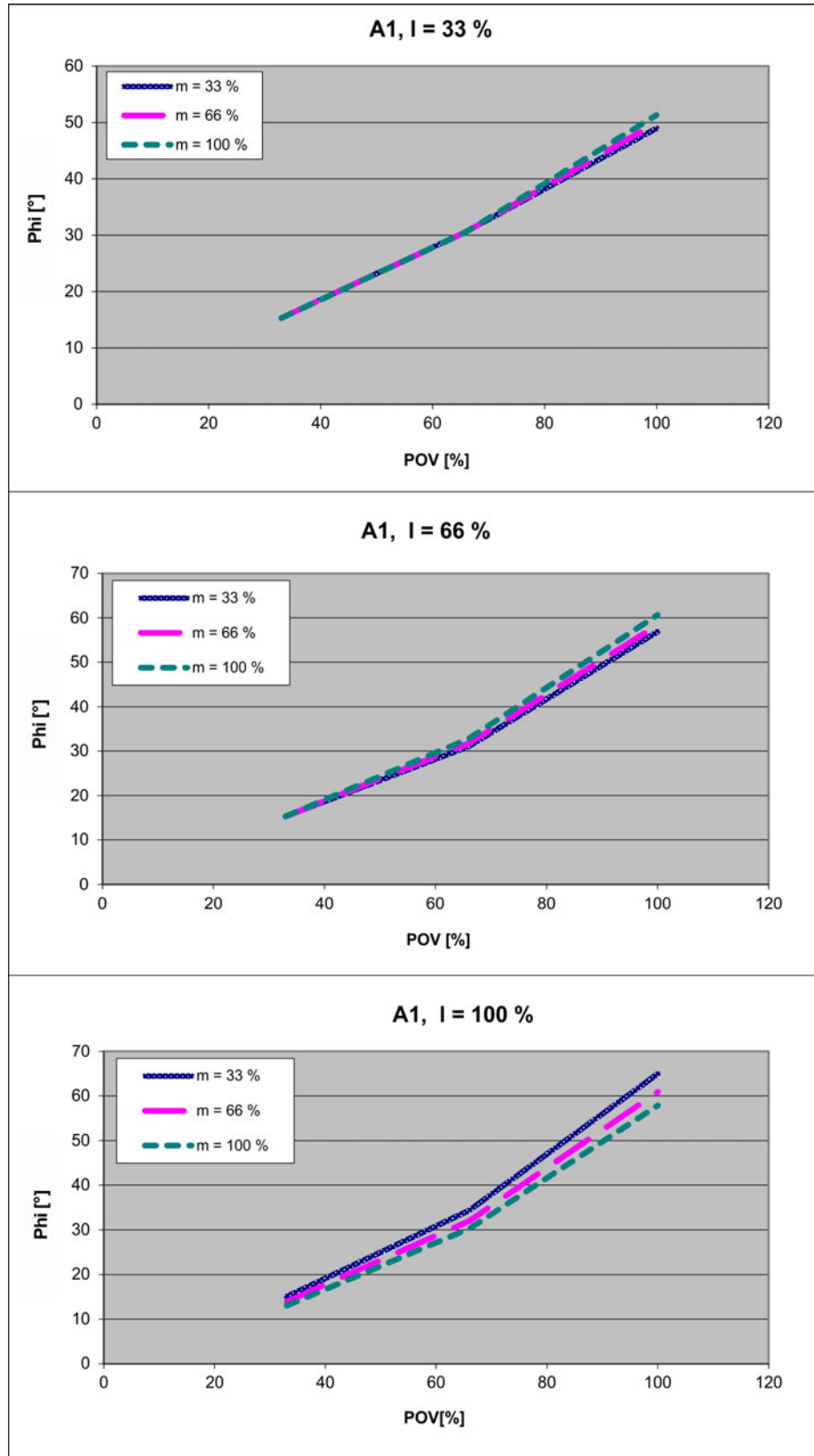

Fig. 4-62: Stopping distances for STOP 1, axis 1

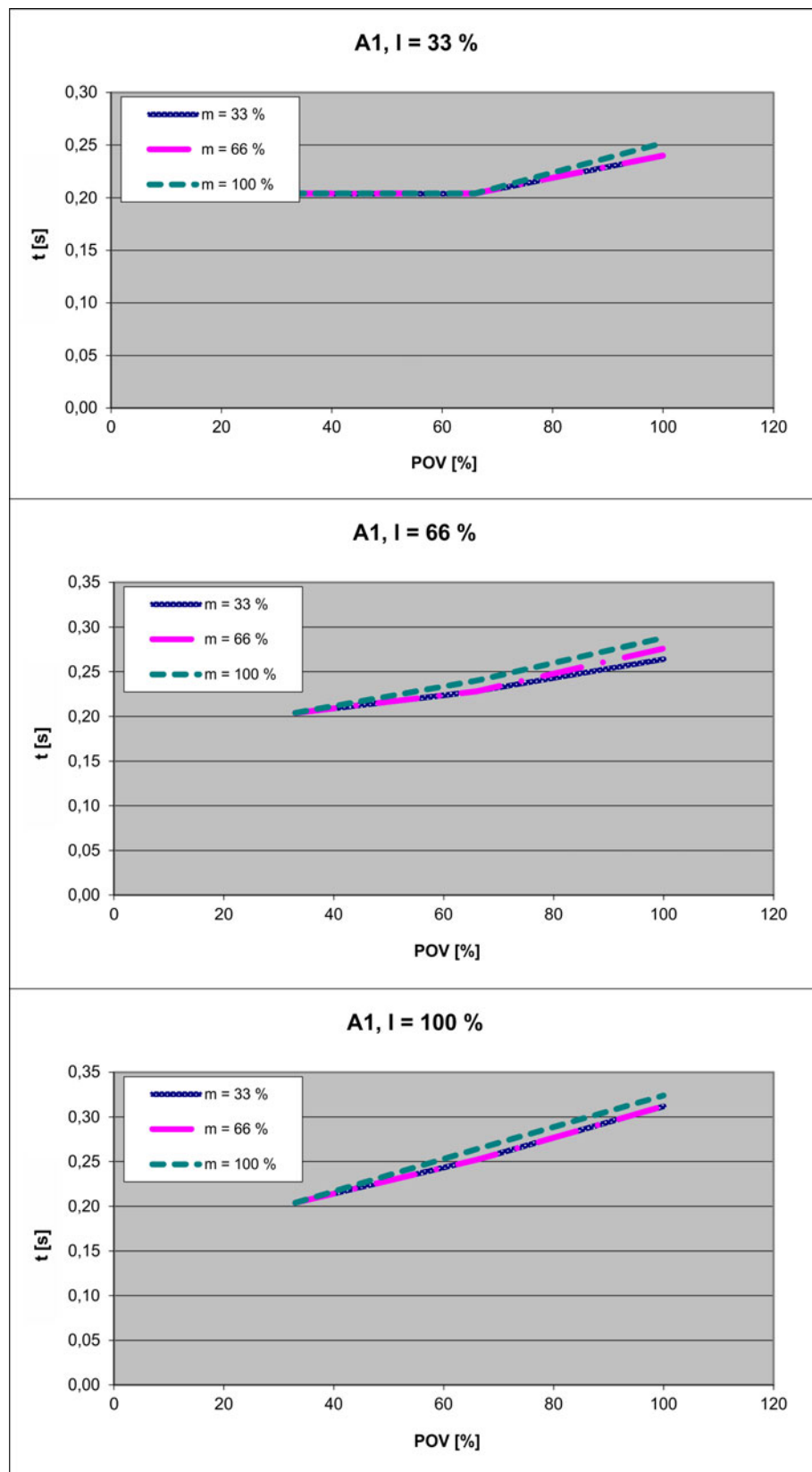

Fig. 4-63: Stopping times for STOP 1, axis 1

4.10.8.3 Stopping distances and stopping times for STOP 1, axis 2

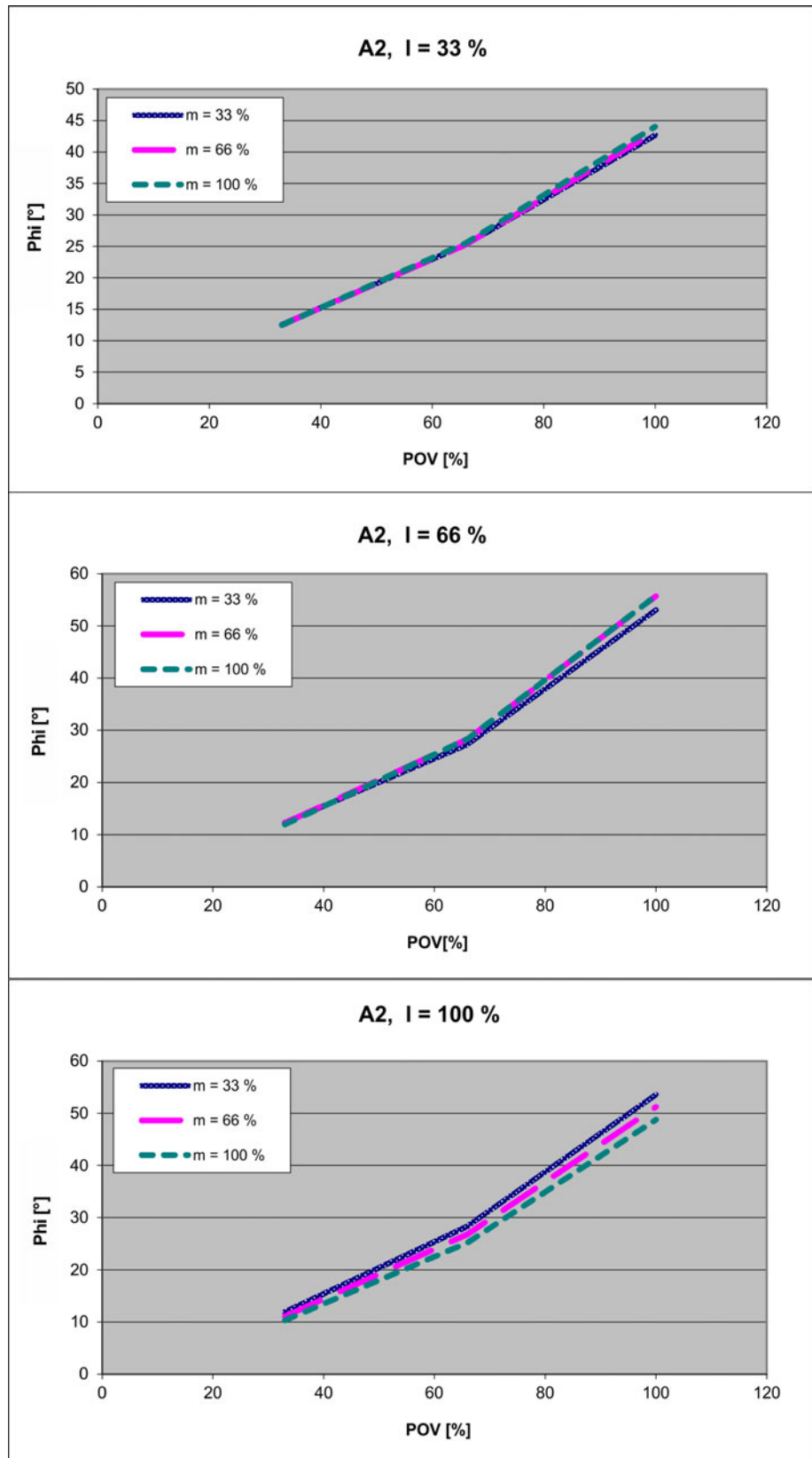

Fig. 4-64: Stopping distances for STOP 1, axis 2

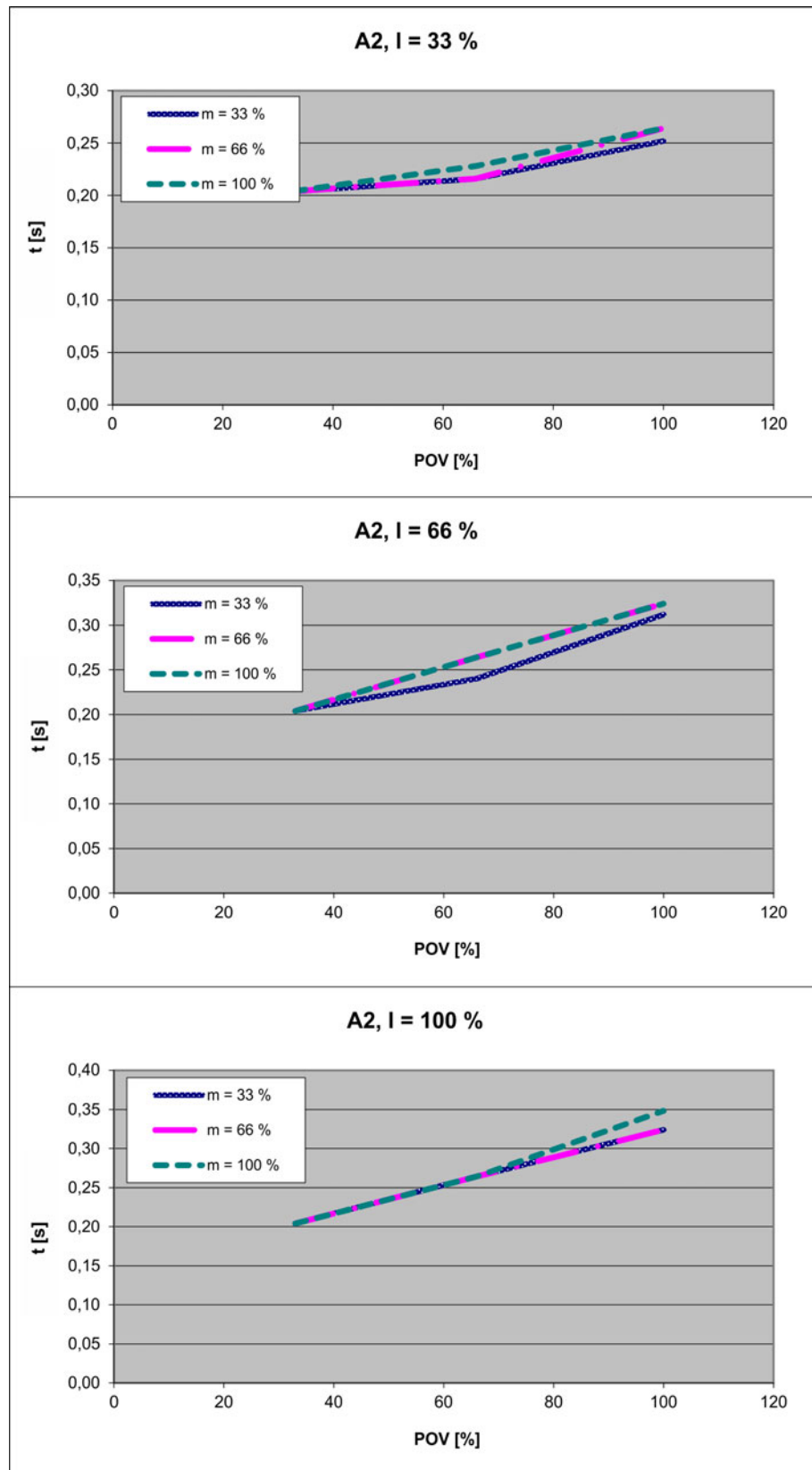

Fig. 4-65: Stopping times for STOP 1, axis 2

4.10.8.4 Stopping distances and stopping times for STOP 1, axis 3

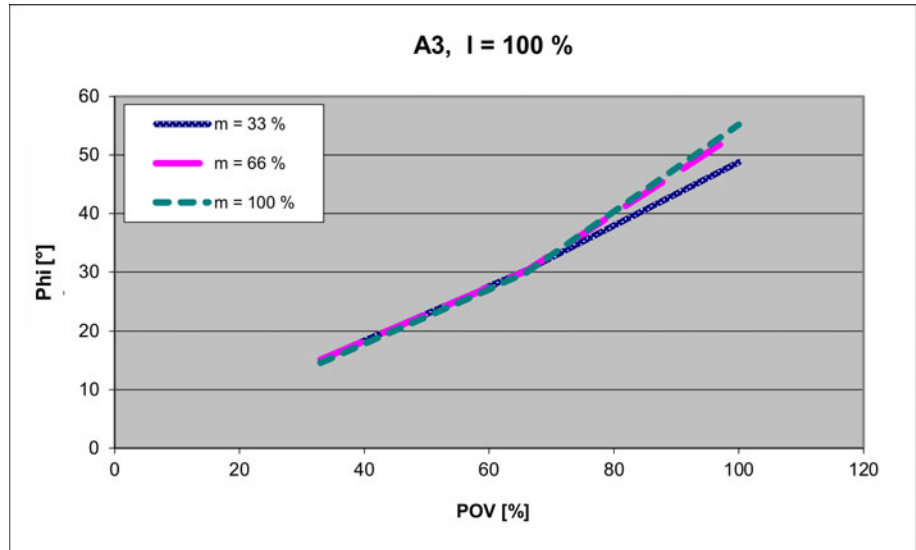

Fig. 4-66: Stopping distances for STOP 1, axis 3

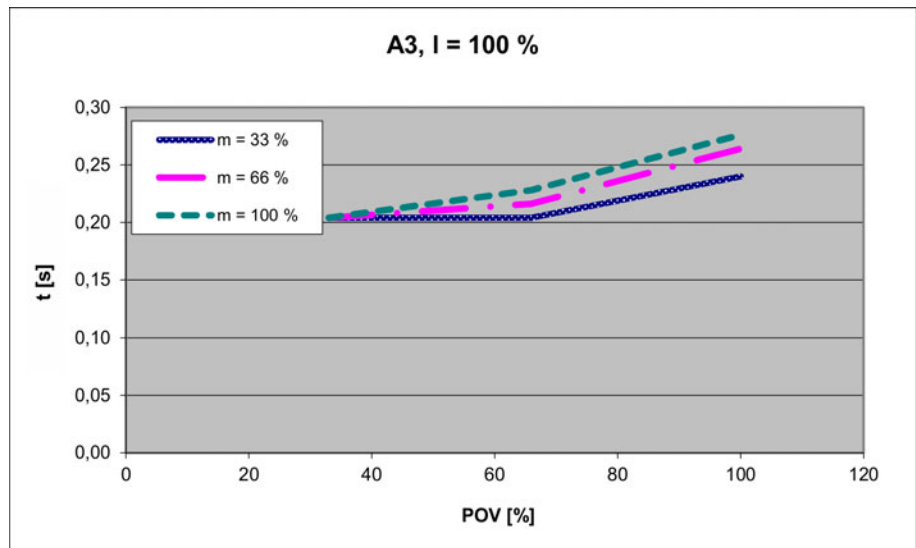

Fig. 4-67: Stopping times for STOP 1, axis 3

5 Safety

5.1 General



■ This “Safety” chapter refers to a mechanical component of an industrial robot.

■ If the mechanical component is used together with a KUKA robot controller, the “Safety” chapter of the operating instructions or assembly instructions of the robot controller must be used!

This contains all the information provided in this “Safety” chapter. It also contains additional safety information relating to the robot controller which must be observed.

■ Where this “Safety” chapter uses the term “industrial robot”, this also refers to the individual mechanical component if applicable.

5.1.1 Liability

The device described in this document is either an industrial robot or a component thereof.

Components of the industrial robot:

- Manipulator
- Robot controller
- Teach pendant
- Connecting cables
- External axes (optional)
e.g. linear unit, turn-tilt table, positioner
- Software
- Options, accessories

The industrial robot is built using state-of-the-art technology and in accordance with the recognized safety rules. Nevertheless, misuse of the industrial robot may constitute a risk to life and limb or cause damage to the industrial robot and to other material property.

The industrial robot may only be used in perfect technical condition in accordance with its designated use and only by safety-conscious persons who are fully aware of the risks involved in its operation. Use of the industrial robot is subject to compliance with this document and with the declaration of incorporation supplied together with the industrial robot. Any functional disorders affecting safety must be rectified immediately.

Safety information

Safety information cannot be held against KUKA Roboter GmbH. Even if all safety instructions are followed, this is not a guarantee that the industrial robot will not cause personal injuries or material damage.

No modifications may be carried out to the industrial robot without the authorization of KUKA Roboter GmbH. Additional components (tools, software, etc.), not supplied by KUKA Roboter GmbH, may be integrated into the industrial robot. The user is liable for any damage these components may cause to the industrial robot or to other material property.

In addition to the Safety chapter, this document contains further safety instructions. These must also be observed.

5.1.2 Intended use of the industrial robot

The industrial robot is intended exclusively for the use designated in the “Purpose” chapter of the operating instructions or assembly instructions.



Further information is contained in the “Purpose” chapter of the operating instructions or assembly instructions of the industrial robot.

Using the industrial robot for any other or additional purpose is considered impermissible misuse. The manufacturer cannot be held liable for any damage resulting from such use. The risk lies entirely with the user.

Operating the industrial robot and its options within the limits of its intended use also involves observance of the operating and assembly instructions for the individual components, with particular reference to the maintenance specifications.

Misuse

Any use or application deviating from the intended use is deemed to be impermissible misuse. This includes e.g.:

- Transportation of persons and animals
- Use as a climbing aid
- Operation outside the permissible operating parameters
- Use in potentially explosive environments
- Operation without additional safeguards
- Outdoor operation
- Underground operation

5.1.3 EC declaration of conformity and declaration of incorporation

This industrial robot constitutes partly completed machinery as defined by the EC Machinery Directive. The industrial robot may only be put into operation if the following preconditions are met:

- The industrial robot is integrated into a complete system.
Or: The industrial robot, together with other machinery, constitutes a complete system.
Or: All safety functions and safeguards required for operation in the complete machine as defined by the EC Machinery Directive have been added to the industrial robot.
- The complete system complies with the EC Machinery Directive. This has been confirmed by means of an assessment of conformity.

Declaration of conformity

The system integrator must issue a declaration of conformity for the complete system in accordance with the Machinery Directive. The declaration of conformity forms the basis for the CE mark for the system. The industrial robot must be operated in accordance with the applicable national laws, regulations and standards.

The robot controller is CE certified under the EMC Directive and the Low Voltage Directive.

Declaration of incorporation

The industrial robot as partly completed machinery is supplied with a declaration of incorporation in accordance with Annex II B of the EC Machinery Directive 2006/42/EC. The assembly instructions and a list of essential requirements complied with in accordance with Annex I are integral parts of this declaration of incorporation.

The declaration of incorporation declares that the start-up of the partly completed machinery remains impermissible until the partly completed machinery

has been incorporated into machinery, or has been assembled with other parts to form machinery, and this machinery complies with the terms of the EC Machinery Directive, and the EC declaration of conformity is present in accordance with Annex II A.

The declaration of incorporation, together with its annexes, remains with the system integrator as an integral part of the technical documentation of the complete machinery.

5.1.4 Terms used

Term	Description
Axis range	Range of each axis, in degrees or millimeters, within which it may move. The axis range must be defined for each axis.
Stopping distance	Stopping distance = reaction distance + braking distance The stopping distance is part of the danger zone.
Workspace	The manipulator is allowed to move within its workspace. The workspace is derived from the individual axis ranges.
Operator (User)	The user of the industrial robot can be the management, employer or delegated person responsible for use of the industrial robot.
Danger zone	The danger zone consists of the workspace and the stopping distances.
Service life	The service life of a safety-relevant component begins at the time of delivery of the component to the customer. The service life is not affected by whether the component is used in a robot controller or elsewhere or not, as safety-relevant components are also subject to ageing during storage.
KCP	KUKA Control Panel Teach pendant for the KR C2/KR C2 edition2005 The KCP has all the operator control and display functions required for operating and programming the industrial robot.
KUKA smartPAD	see "smartPAD"
Manipulator	The robot arm and the associated electrical installations
Safety zone	The safety zone is situated outside the danger zone.
smartPAD	Teach pendant for the KR C4 The smartPAD has all the operator control and display functions required for operating and programming the industrial robot.
Stop category 0	The drives are deactivated immediately and the brakes are applied. The manipulator and any external axes (optional) perform path-oriented braking. Note: This stop category is called STOP 0 in this document.
Stop category 1	The manipulator and any external axes (optional) perform path-maintaining braking. The drives are deactivated after 1 s and the brakes are applied. Note: This stop category is called STOP 1 in this document.
Stop category 2	The drives are not deactivated and the brakes are not applied. The manipulator and any external axes (optional) are braked with a normal braking ramp. Note: This stop category is called STOP 2 in this document.
System integrator (plant integrator)	System integrators are people who safely integrate the industrial robot into a complete system and commission it.
T1	Test mode, Manual Reduced Velocity (<= 250 mm/s)

Term	Description
T2	Test mode, Manual High Velocity (> 250 mm/s permissible)
External axis	Motion axis which is not part of the manipulator but which is controlled using the robot controller, e.g. KUKA linear unit, turn-tilt table, Posiflex.

5.2 Personnel

The following persons or groups of persons are defined for the industrial robot:

- User
- Personnel



All persons working with the industrial robot must have read and understood the industrial robot documentation, including the safety chapter.

User

The user must observe the labor laws and regulations. This includes e.g.:

- The user must comply with his monitoring obligations.
- The user must carry out instructions at defined intervals.

Personnel

Personnel must be instructed, before any work is commenced, in the type of work involved and what exactly it entails as well as any hazards which may exist. Instruction must be carried out regularly. Instruction is also required after particular incidents or technical modifications.

Personnel includes:

- System integrator
- Operators, subdivided into:
 - Start-up, maintenance and service personnel
 - Operating personnel
 - Cleaning personnel



Installation, exchange, adjustment, operation, maintenance and repair must be performed only as specified in the operating or assembly instructions for the relevant component of the industrial robot and only by personnel specially trained for this purpose.

System integrator

The industrial robot is safely integrated into a complete system by the system integrator.

The system integrator is responsible for the following tasks:

- Installing the industrial robot
- Connecting the industrial robot
- Performing risk assessment
- Implementing the required safety functions and safeguards
- Issuing the declaration of conformity
- Attaching the CE mark
- Creating the operating instructions for the complete system

Operator

The operator must meet the following preconditions:

- The operator must be trained for the work to be carried out.
- Work on the industrial robot must only be carried out by qualified personnel. These are people who, due to their specialist training, knowledge and experience, and their familiarization with the relevant standards, are able to assess the work to be carried out and detect any potential hazards.

Example

The tasks can be distributed as shown in the following table.

Tasks	Operator	Programmer	System integrator
Switch robot controller on/off	x	x	x
Start program	x	x	x
Select program	x	x	x
Select operating mode	x	x	x
Calibration (tool, base)		x	x
Master the manipulator		x	x
Configuration		x	x
Programming		x	x
Start-up			x
Maintenance			x
Repair			x
Shutting down			x
Transportation			x



Work on the electrical and mechanical equipment of the industrial robot may only be carried out by specially trained personnel.

5.3 Workspace, safety zone and danger zone

Workspaces are to be restricted to the necessary minimum size. A workspace must be safeguarded using appropriate safeguards.

The safeguards (e.g. safety gate) must be situated inside the safety zone. In the case of a stop, the manipulator and external axes (optional) are braked and come to a stop within the danger zone.

The danger zone consists of the workspace and the stopping distances of the manipulator and external axes (optional). It must be safeguarded by means of physical safeguards to prevent danger to persons or the risk of material damage.

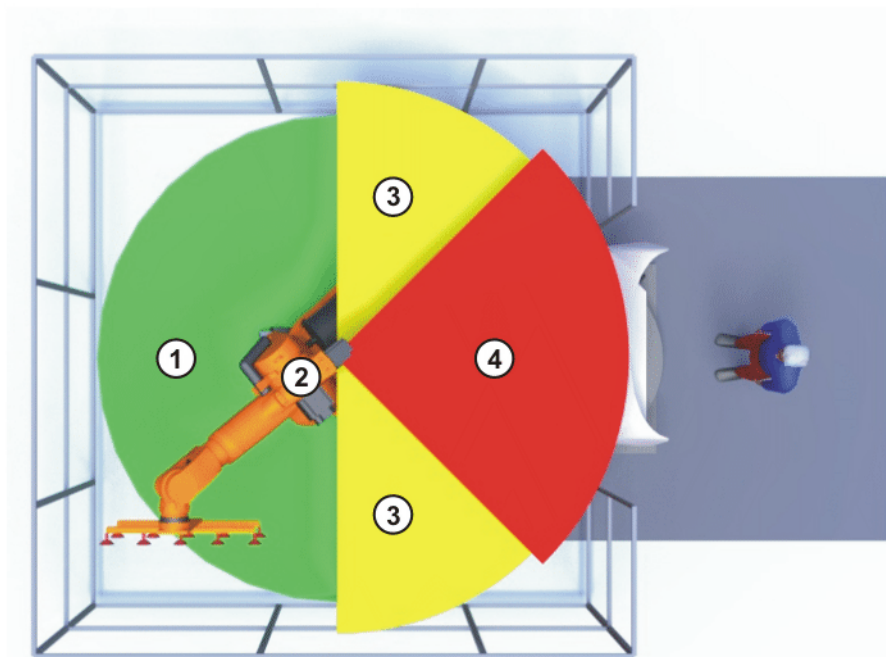

Fig. 5-1: Example of axis range A1

- | | | | |
|---|-------------|---|-------------------|
| 1 | Workspace | 3 | Stopping distance |
| 2 | Manipulator | 4 | Safety zone |

5.4 Overview of protective equipment

The protective equipment of the mechanical component may include:

- Mechanical end stops
- Mechanical axis range limitation (optional)
- Axis range monitoring (optional)
- Release device (optional)
- Labeling of danger areas

Not all equipment is relevant for every mechanical component.

5.4.1 Mechanical end stops

Depending on the robot variant, the axis ranges of the main and wrist axes of the manipulator are partially limited by mechanical end stops.

Additional mechanical end stops can be installed on the external axes.

⚠ WARNING If the manipulator or an external axis hits an obstruction or a mechanical end stop or axis range limitation, this can result in material damage to the industrial robot. The manipulator must be taken out of operation and KUKA Roboter GmbH must be consulted before it is put back into operation (>>> 8 "KUKA Service" Page 117).

5.4.2 Mechanical axis range limitation (optional)

Some manipulators can be fitted with mechanical axis range limitation in axes A1 to A3. The adjustable axis range limitation systems restrict the working range to the required minimum. This increases personal safety and protection of the system.

In the case of manipulators that are not designed to be fitted with mechanical axis range limitation, the workspace must be laid out in such a way that there is no danger to persons or material property, even in the absence of mechanical axis range limitation.

If this is not possible, the workspace must be limited by means of photoelectric barriers, photoelectric curtains or obstacles on the system side. There must be no shearing or crushing hazards at the loading and transfer areas.

 This option is not available for all robot models. Information on specific robot models can be obtained from KUKA Roboter GmbH.

5.4.3 Axis range monitoring (optional)

Some manipulators can be fitted with dual-channel axis range monitoring systems in main axes A1 to A3. The positioner axes may be fitted with additional axis range monitoring systems. The safety zone for an axis can be adjusted and monitored using an axis range monitoring system. This increases personal safety and protection of the system.

 This option is not available for all robot models. Information on specific robot models can be obtained from KUKA Roboter GmbH.

5.4.4 Options for moving the manipulator without drive energy

 The system user is responsible for ensuring that the training of personnel with regard to the response to emergencies or exceptional situations also includes how the manipulator can be moved without drive energy.

Description

The following options are available for moving the manipulator without drive energy after an accident or malfunction:

- Release device (optional)
The release device can be used for the main axis drive motors and, depending on the robot variant, also for the wrist axis drive motors.
- Brake release device (option)
The brake release device is designed for robot variants whose motors are not freely accessible.
- Moving the wrist axes directly by hand
There is no release device available for the wrist axes of variants in the low payload category. This is not necessary because the wrist axes can be moved directly by hand.

 Information about the options available for the various robot models and about how to use them can be found in the assembly and operating instructions for the robot or requested from KUKA Roboter GmbH.

NOTICE Moving the manipulator without drive energy can damage the motor brakes of the axes concerned. The motor must be replaced if the brake has been damaged. The manipulator may therefore be moved without drive energy only in emergencies or exceptional situations, e.g. for rescuing persons.

5.4.5 Labeling on the industrial robot

All plates, labels, symbols and marks constitute safety-relevant parts of the industrial robot. They must not be modified or removed.

Labeling on the industrial robot consists of:

- Identification plates
- Warning labels
- Safety symbols
- Designation labels
- Cable markings
- Rating plates

	Further information is contained in the technical data of the operating instructions or assembly instructions of the components of the industrial robot.
---	--

5.5 Safety measures

5.5.1 General safety measures

The industrial robot may only be used in perfect technical condition in accordance with its intended use and only by safety-conscious persons. Operator errors can result in personal injury and damage to property.

It is important to be prepared for possible movements of the industrial robot even after the robot controller has been switched off and locked. Incorrect installation (e.g. overload) or mechanical defects (e.g. brake defect) can cause the manipulator or external axes to sag. If work is to be carried out on a switched-off industrial robot, the manipulator and external axes must first be moved into a position in which they are unable to move on their own, whether the payload is mounted or not. If this is not possible, the manipulator and external axes must be secured by appropriate means.

 DANGER	In the absence of operational safety functions and safeguards, the industrial robot can cause personal injury or material damage. If safety functions or safeguards are dismantled or deactivated, the industrial robot may not be operated.
---	--

 DANGER	Standing underneath the robot arm can cause death or serious injuries. For this reason, standing underneath the robot arm is prohibited!
---	--

 CAUTION	The motors reach temperatures during operation which can cause burns to the skin. Contact must be avoided. Appropriate safety precautions must be taken, e.g. protective gloves must be worn.
--	---

KCP

The user must ensure that the industrial robot is only operated with the KCP by authorized persons.

If more than one KCP is used in the overall system, it must be ensured that each KCP is unambiguously assigned to the corresponding industrial robot. They must not be interchanged.

⚠ WARNING The operator must ensure that decoupled KCPs are immediately removed from the system and stored out of sight and reach of personnel working on the industrial robot. This serves to prevent operational and non-operational EMERGENCY STOP devices from becoming interchanged. Failure to observe this precaution may result in death, severe injuries or considerable damage to property.

External keyboard, external mouse

An external keyboard and/or external mouse may only be used if the following conditions are met:

- Start-up or maintenance work is being carried out.
- The drives are switched off.
- There are no persons in the danger zone.

The KCP must not be used as long as an external keyboard and/or external mouse are connected.

The external keyboard and/or external mouse must be removed as soon as the start-up or maintenance work is completed or the KCP is connected.

Faults

The following tasks must be carried out in the case of faults in the industrial robot:

- Switch off the robot controller and secure it (e.g. with a padlock) to prevent unauthorized persons from switching it on again.
- Indicate the fault by means of a label with a corresponding warning (tag-out).
- Keep a record of the faults.
- Eliminate the fault and carry out a function test.

Modifications

After modifications to the industrial robot, checks must be carried out to ensure the required safety level. The valid national or regional work safety regulations must be observed for this check. The correct functioning of all safety circuits must also be tested.

New or modified programs must always be tested first in Manual Reduced Velocity mode (T1).

After modifications to the industrial robot, existing programs must always be tested first in Manual Reduced Velocity mode (T1). This applies to all components of the industrial robot and includes modifications to the software and configuration settings.

5.5.2 Transportation

Manipulator

The prescribed transport position of the manipulator must be observed. Transportation must be carried out in accordance with the operating instructions or assembly instructions of the robot.

Robot controller

The prescribed transport position of the robot controller must be observed. Transportation must be carried out in accordance with the operating instructions or assembly instructions of the robot controller.

Avoid vibrations and impacts during transportation in order to prevent damage to the robot controller.

External axis (optional)

The prescribed transport position of the external axis (e.g. KUKA linear unit, turn-tilt table, positioner) must be observed. Transportation must be carried out in accordance with the operating instructions or assembly instructions of the external axis.

5.5.3 Start-up and recommissioning

Before starting up systems and devices for the first time, a check must be carried out to ensure that the systems and devices are complete and operational, that they can be operated safely and that any damage is detected.

The valid national or regional work safety regulations must be observed for this check. The correct functioning of all safety circuits must also be tested.



The passwords for logging onto the KUKA System Software as “Expert” and “Administrator” must be changed before start-up and must only be communicated to authorized personnel.



The robot controller is preconfigured for the specific industrial robot. If cables are interchanged, the manipulator and the external axes (optional) may receive incorrect data and can thus cause personal injury or material damage. If a system consists of more than one manipulator, always connect the connecting cables to the manipulators and their corresponding robot controllers.



If additional components (e.g. cables), which are not part of the scope of supply of KUKA Roboter GmbH, are integrated into the industrial robot, the user is responsible for ensuring that these components do not adversely affect or disable safety functions.

NOTICE

If the internal cabinet temperature of the robot controller differs greatly from the ambient temperature, condensation can form, which may cause damage to the electrical components. Do not put the robot controller into operation until the internal temperature of the cabinet has adjusted to the ambient temperature.

Function test

The following tests must be carried out before start-up and recommissioning: It must be ensured that:

- The industrial robot is correctly installed and fastened in accordance with the specifications in the documentation.
- There are no foreign bodies or loose parts on the industrial robot.
- All required safety equipment is correctly installed and operational.
- The power supply ratings of the industrial robot correspond to the local supply voltage and mains type.
- The ground conductor and the equipotential bonding cable are sufficiently rated and correctly connected.
- The connecting cables are correctly connected and the connectors are locked.

Machine data

It must be ensured that the rating plate on the robot controller has the same machine data as those entered in the declaration of incorporation. The machine data on the rating plate of the manipulator and the external axes (optional) must be entered during start-up.



WARNING The industrial robot must not be moved if incorrect machine data are loaded. Death, severe injuries or considerable damage to property may otherwise result. The correct machine data must be loaded.

5.5.4 Manual mode

Manual mode is the mode for setup work. Setup work is all the tasks that have to be carried out on the industrial robot to enable automatic operation. Setup work includes:

- Jog mode
- Teach
- Programming
- Program verification

The following must be taken into consideration in manual mode:

- If the drives are not required, they must be switched off to prevent the manipulator or the external axes (optional) from being moved unintentionally. New or modified programs must always be tested first in Manual Reduced Velocity mode (T1).
- The manipulator, tooling or external axes (optional) must never touch or project beyond the safety fence.
- Workpieces, tooling and other objects must not become jammed as a result of the industrial robot motion, nor must they lead to short-circuits or be liable to fall off.
- All setup work must be carried out, where possible, from outside the safeguarded area.

If the setup work has to be carried out inside the safeguarded area, the following must be taken into consideration:

In **Manual Reduced Velocity mode (T1)**:

- If it can be avoided, there must be no other persons inside the safeguarded area.
If it is necessary for there to be several persons inside the safeguarded area, the following must be observed:
 - Each person must have an enabling device.
 - All persons must have an unimpeded view of the industrial robot.
 - Eye-contact between all persons must be possible at all times.
- The operator must be so positioned that he can see into the danger area and get out of harm's way.

In **Manual High Velocity mode (T2)**:

- This mode may only be used if the application requires a test at a velocity higher than Manual Reduced Velocity.
- Teaching and programming are not permissible in this operating mode.
- Before commencing the test, the operator must ensure that the enabling devices are operational.
- The operator must be positioned outside the danger zone.
- There must be no other persons inside the safeguarded area. It is the responsibility of the operator to ensure this.

5.5.5 Automatic mode

Automatic mode is only permissible in compliance with the following safety measures:

- All safety equipment and safeguards are present and operational.
- There are no persons in the system.
- The defined working procedures are adhered to.

If the manipulator or an external axis (optional) comes to a standstill for no apparent reason, the danger zone must not be entered until an EMERGENCY STOP has been triggered.

5.5.6 Maintenance and repair

After maintenance and repair work, checks must be carried out to ensure the required safety level. The valid national or regional work safety regulations must be observed for this check. The correct functioning of all safety functions must also be tested.

The purpose of maintenance and repair work is to ensure that the system is kept operational or, in the event of a fault, to return the system to an operational state. Repair work includes troubleshooting in addition to the actual repair itself.

The following safety measures must be carried out when working on the industrial robot:

- Carry out work outside the danger zone. If work inside the danger zone is necessary, the user must define additional safety measures to ensure the safe protection of personnel.
- Switch off the industrial robot and secure it (e.g. with a padlock) to prevent it from being switched on again. If it is necessary to carry out work with the robot controller switched on, the user must define additional safety measures to ensure the safe protection of personnel.
- If it is necessary to carry out work with the robot controller switched on, this may only be done in operating mode T1.
- Label the system with a sign indicating that work is in progress. This sign must remain in place, even during temporary interruptions to the work.
- The EMERGENCY STOP systems must remain active. If safety functions or safeguards are deactivated during maintenance or repair work, they must be reactivated immediately after the work is completed.



WARNING

Before work is commenced on live parts of the robot system, the main switch must be turned off and secured against being switched on again by unauthorized personnel. The incoming power cable must be deenergized. The robot controller and mains supply lead must then be checked to ensure that it is deenergized.

If the KR C4 or VKR C4 robot controller is used:

It is not sufficient, before commencing work on live parts, to execute an EMERGENCY STOP or a safety stop, or to switch off the drives, as this does not disconnect the robot system from the mains power supply in the case of the drives of the new generation. Parts remain energized. Death or severe injuries may result.

Faulty components must be replaced using new components with the same article numbers or equivalent components approved by KUKA Roboter GmbH for this purpose.

Cleaning and preventive maintenance work is to be carried out in accordance with the operating instructions.

Robot controller

Even when the robot controller is switched off, parts connected to peripheral devices may still carry voltage. The external power sources must therefore be switched off if work is to be carried out on the robot controller.

The ESD regulations must be adhered to when working on components in the robot controller.

Voltages in excess of 50 V (up to 600 V) can be present in various components for several minutes after the robot controller has been switched off! To prevent

life-threatening injuries, no work may be carried out on the industrial robot in this time.

Water and dust must be prevented from entering the robot controller.

Counterbalancing system

Some robot variants are equipped with a hydropneumatic, spring or gas cylinder counterbalancing system.

The hydropneumatic and gas cylinder counterbalancing systems are pressure equipment and, as such, are subject to obligatory equipment monitoring. Depending on the robot variant, the counterbalancing systems correspond to category 0, II or III, fluid group 2, of the Pressure Equipment Directive.

The user must comply with the applicable national laws, regulations and standards pertaining to pressure equipment.

Inspection intervals in Germany in accordance with Industrial Safety Order, Sections 14 and 15. Inspection by the user before commissioning at the installation site.

The following safety measures must be carried out when working on the counterbalancing system:

- The manipulator assemblies supported by the counterbalancing systems must be secured.
- Work on the counterbalancing systems must only be carried out by qualified personnel.

Hazardous substances

The following safety measures must be carried out when handling hazardous substances:

- Avoid prolonged and repeated intensive contact with the skin.
- Avoid breathing in oil spray or vapors.
- Clean skin and apply skin cream.



To ensure safe use of our products, we recommend that our customers regularly request up-to-date safety data sheets from the manufacturers of hazardous substances.

5.5.7 Decommissioning, storage and disposal

The industrial robot must be decommissioned, stored and disposed of in accordance with the applicable national laws, regulations and standards.

5.6 Applied norms and regulations

Name	Definition	Edition
2006/42/EC	Machinery Directive: Directive 2006/42/EC of the European Parliament and of the Council of 17 May 2006 on machinery, and amending Directive 95/16/EC (recast)	2006
2004/108/EC	EMC Directive: Directive 2004/108/EC of the European Parliament and of the Council of 15 December 2004 on the approximation of the laws of the Member States relating to electromagnetic compatibility and repealing Directive 89/336/EEC	2004

Name	Definition	Edition
97/23/EC	Pressure Equipment Directive: Directive 97/23/EC of the European Parliament and of the Council of 29 May 1997 on the approximation of the laws of the Member States concerning pressure equipment (Only applicable for robots with hydropneumatic counterbalancing system.)	1997
EN ISO 13850	Safety of machinery: Emergency stop - Principles for design	2008
EN ISO 13849-1	Safety of machinery: Safety-related parts of control systems - Part 1: General principles of design	2008
EN ISO 13849-2	Safety of machinery: Safety-related parts of control systems - Part 2: Validation	2008
EN ISO 12100	Safety of machinery: General principles of design, risk assessment and risk reduction	2010
EN ISO 10218-1	Industrial robots: Safety	2011
EN 614-1	Safety of machinery: Ergonomic design principles - Part 1: Terms and general principles	2006
EN 61000-6-2	Electromagnetic compatibility (EMC): Part 6-2: Generic standards; Immunity for industrial environments	2005
EN 61000-6-4	Electromagnetic compatibility (EMC): Part 6-4: Generic standards; Emission standard for industrial environments	2007
EN 60204-1	Safety of machinery: Electrical equipment of machines - Part 1: General requirements	2006

6 Planning

6.1 Mounting base

Description The mounting base with centering is used when the robot is fastened to the floor, i.e. directly on a concrete foundation.

The mounting base consists of:

- Bedplate
- Chemical anchors (resin-bonded anchors) with Dynamic Set
- Fasteners

This mounting variant requires a level and smooth surface on a concrete foundation with adequate load bearing capacity. The concrete foundation must be able to accommodate the forces occurring during operation. The minimum dimensions must be observed.

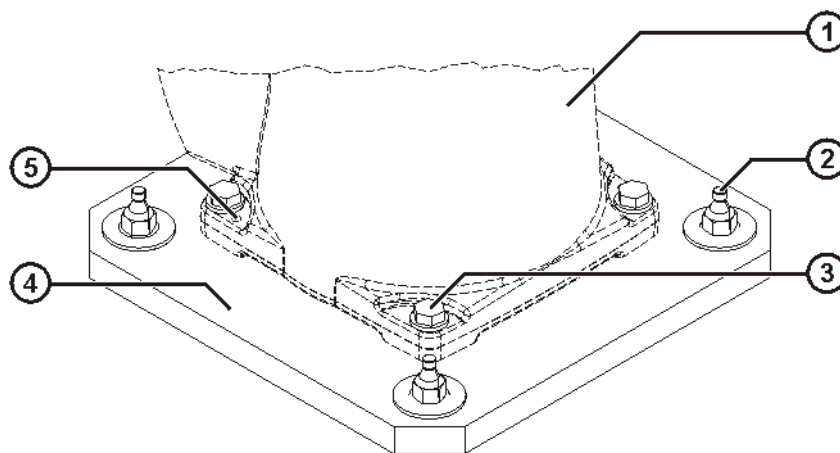

Fig. 6-1: Mounting base

- | | |
|---|------------|
| 1 Robot base frame | 4 Bedplate |
| 2 Chemical anchor (resin-bonded anchor) | 5 Pin |
| 3 Hexagon bolt | |

Grade of concrete for foundations When producing foundations from concrete, observe the load-bearing capacity of the ground and the country-specific construction regulations. There must be no layers of insulation or screed between the bedplates and the concrete foundation. The quality of the concrete must meet the requirements of the following standard:

- C20/25 according to DIN EN 206-1:2001/DIN 1045-2:2008

Dimensioned drawing The following illustration (>>> Fig. 6-2) provides all the necessary information on the mounting base, together with the required foundation data.

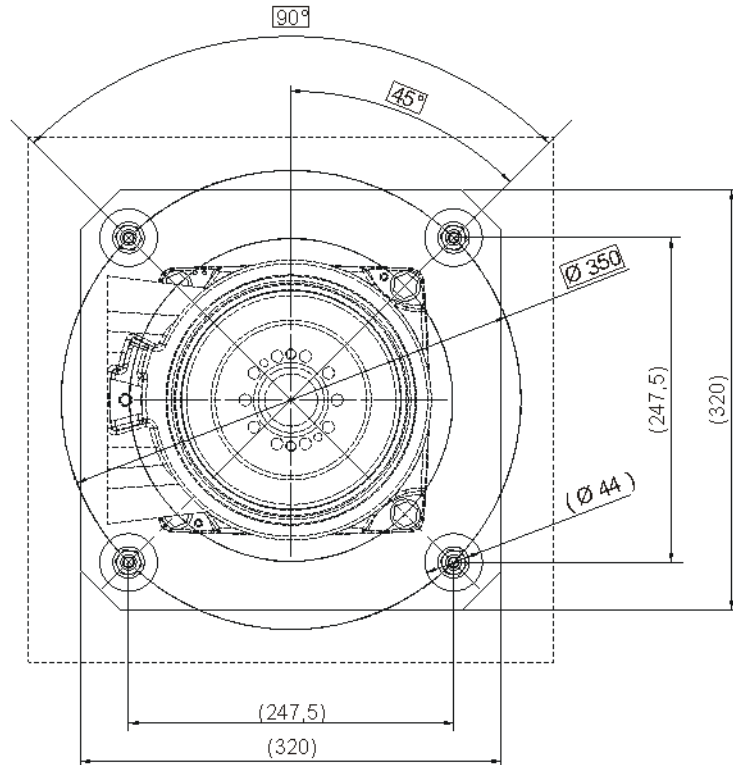

Fig. 6-2: Dimensioned drawing, mounting base

To ensure that the anchor forces are safely transmitted to the foundation, observe the dimensions for concrete foundations specified in the following illustration (>>> Fig. 6-3).

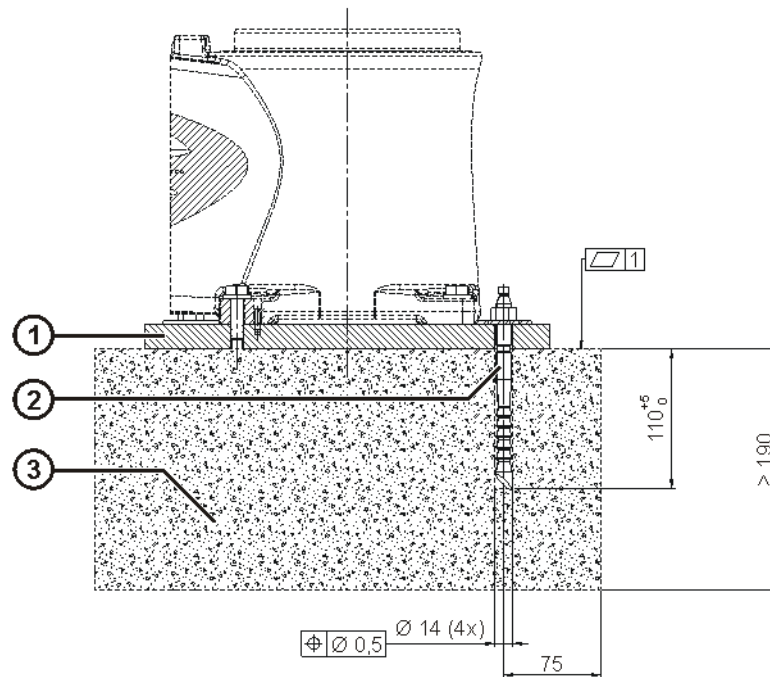

Fig. 6-3: Cross-section of foundations

- 1 Bedplate

- 2 Chemical anchors (resin-bonded anchors) with Dynamic Set
- 3 Concrete foundation

6.2 Machine frame mounting

Description

The machine frame mounting assembly is used when the robot is fastened on a steel structure, a booster frame (pedestal) or a KUKA linear unit. This assembly is also used if the robot is installed on the wall or ceiling. It must be ensured that the substructure is able to withstand safely the forces occurring during operation (foundation loads). The following diagram contains all the necessary information that must be observed when preparing the mounting surface (>>> Fig. 6-4).

The machine frame mounting assembly consists of:

- Pin
- Hexagon bolts with conical spring washers

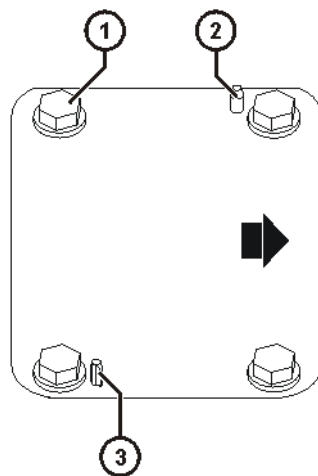

Fig. 6-4: Machine frame mounting

- 1 Hexagon bolt
- 2 Cylindrical pin
- 3 Flat-sided pin

Dimensioned drawing

The following illustration (>>> Fig. 6-5) provides all the necessary information on machine frame mounting, together with the required foundation data.

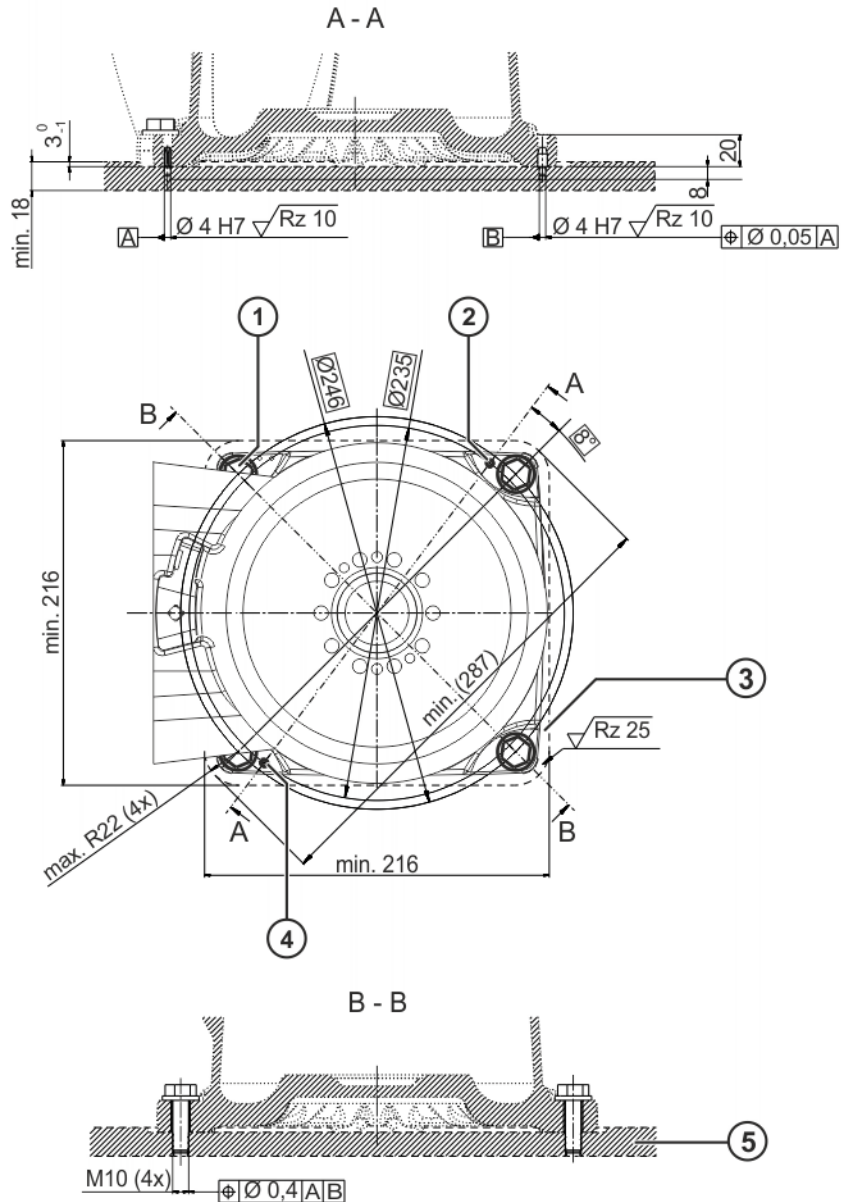

Fig. 6-5: Machine frame mounting, dimensioned drawing

- | | |
|---------------------|-------------------|
| 1 Hexagon bolt (4x) | 4 Flat-sided pin |
| 2 Cylindrical pin | 5 Steel structure |
| 3 Mounting surface | |

6.3 Connecting cables and interfaces

Connecting cables

The connecting cables comprise all the cables for transferring energy and signals between the robot and the robot controller. They are connected to the robot junction boxes with connectors. The set of connecting cables comprises:

- Motor cable
- Data cable
- CAT5 data cable (optional)
- Connecting cable, external axes A7 and A8 (optional)
- Ground conductor (optional)

Depending on the specification of the robot, various connecting cables are used. The standard cable length is 4 m. Cable lengths of 1 m, 7 m, 15 m and 25 m are available as an option. The maximum length of the connecting cables must not exceed 25 m. Thus if the robot is operated on a linear unit which has its own energy supply chain these cables must also be taken into account.



For the connecting cables, a ground conductor is always required to provide a low-resistance connection between the robot and the control cabinet in accordance with DIN EN 60204. The ground conductor is not part of the scope of supply and can be ordered as an option. The connection must be made by the customer. The tapped holes for connecting the ground conductor are located on the base frame of the robot.

The following points must be observed when planning and routing the connecting cables:

- The bending radius for fixed routing must not be less than 50 mm for motor cables and 30 mm for control cables.
- Protect cables against exposure to mechanical stress.
- Route the cables without mechanical stress – no tensile forces on the connectors
- Cables are only to be installed indoors.
- Observe permissible temperature range (fixed installation) of 263 K (-10 °C) to 343 K (+70 °C).
- Route the motor cables and the control cables separately in metal ducts; if necessary, additional measures must be taken to ensure electromagnetic compatibility (EMC).

Interface A1

Interface A1 is located at the rear of the base frame. The connections for the motor and data cables are shown in the following illustration.

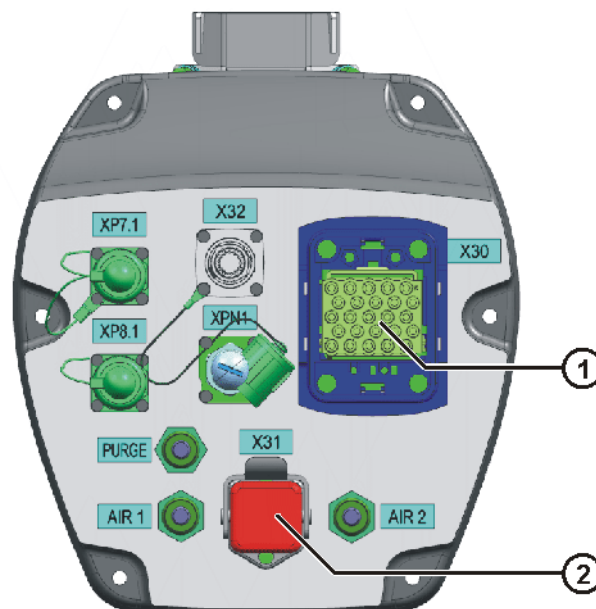

Fig. 6-6: Interface A1

- 1 Connection, motor cable X30
- 2 Connection, data cable, X31

6.4 Customer interfaces

Interface A1 Interface A1 is located at the rear of the base frame.

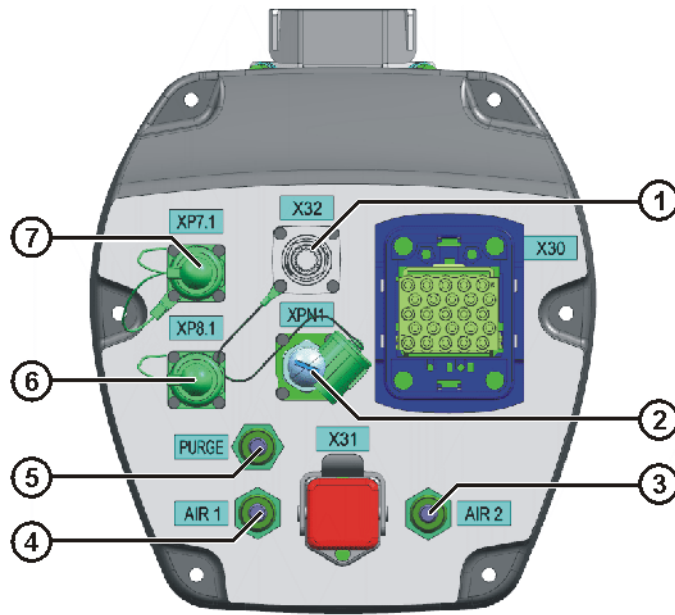

Fig. 6-7: Customer interface A1

- 1 MicroEMD connection X32
- 2 Connection for data cable CAT5 XPN1
- 3 Air line connection AIR2
- 4 Air line connection AIR1
- 5 Pressurization connection (optional)

Max. pressure: 0.3 bar
 Air, oil-free, dry, filtered
 in accordance with: ISO 8573.1-1, 1.2 to 16.2

- 6 Connection for external axis A8 (XP8.1)
- 7 Connection for external axis A7 (XP7.1)

Interface A4

Interface A4 is located on top of the in-line wrist.

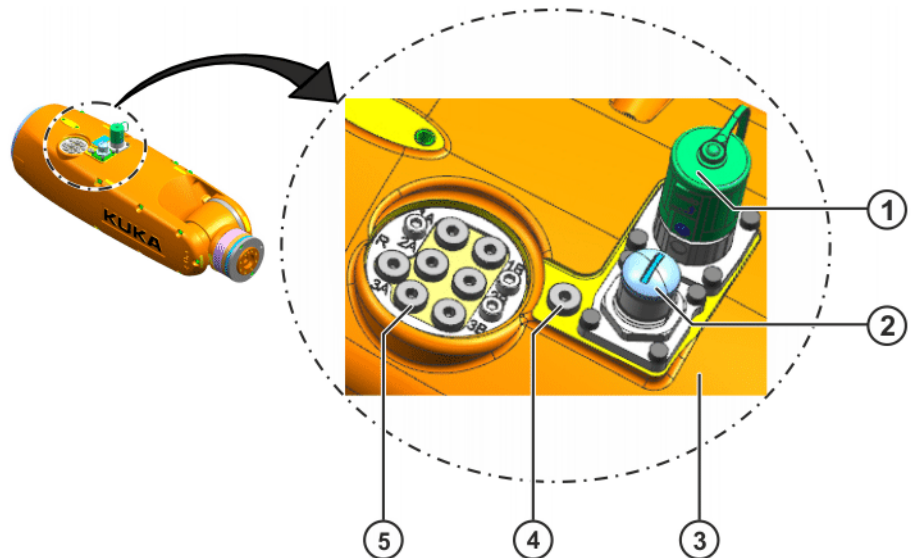

Fig. 6-8: Interface A4, example

- 1 Connection X41
- 2 Air line AIR2
- 3 Air line AIR1
- 4 Air line AIR2
- 5 Connection X41

- 2 Connection XPN41
- 3 In-line wrist
- 5 Air connections

The optional connector bypack is required for use of the air connections. This option contains a silencer and several plug-in couplings (>>> Fig. 6-9).

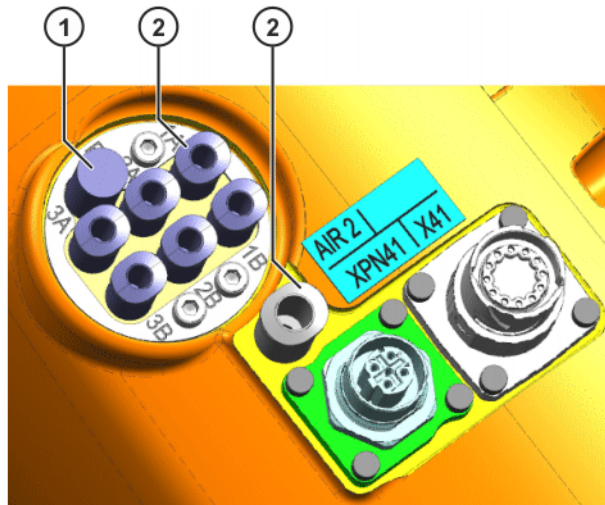

Fig. 6-9: Connector bypack option

- 1 Silencer
- 2 Push-in fitting

The robot has three bistable 5/2-way solenoid valves integrated into the in-line wrist. The valve unit is activated via the internal energy supply system:

Designation	Limit values
Valve type	5/2-way solenoid valve
Max. pressure	7 bar
Switching frequency	10 Hz
Operating temperature	+5 °C to +45 °C (278 K to 318 K) condensation-free
Threaded union	M5
Medium	Air, oil-free, dry, filtered in accordance with: ISO 8573.1-1, 1.2 to 16.2 Degree of filtration: max. 5 µm
Operating voltage	24 V DC
Current	25 mA

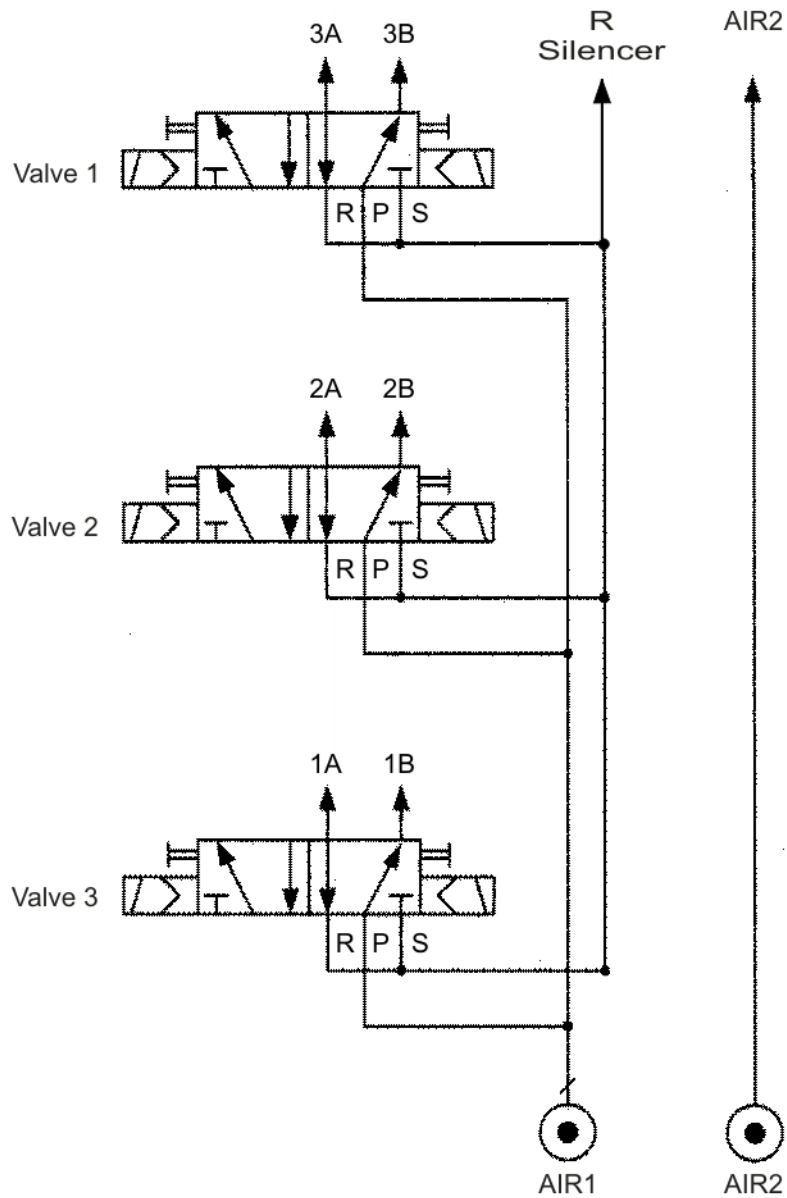

Fig. 6-10: Valve diagram

Valve activation

Designation	Values
Digital outputs (for valve activation)	6 (DO7 to DO12): <ul style="list-style-type: none"> ■ Valve 1: DO7/DO10 ■ Valve 2: DO8/DO11 ■ Valve 3: DO9/DO12 not short circuit proof
Rated voltage	24 V DC (-15%/+20%)
Output current	max. 25 mA

i The inputs and outputs are not preconfigured and must be configured in WorkVisual.
 Further information about mapping inputs and outputs can be found in the **WorkVisual** documentation.

Connection X41

Designation	Values
Digital outputs (for customer interface X41)	2 (DO13, DO14) short-circuit proof
Rated voltage	24 V DC (-15%/+20%)
Output current	Max. 0.5 A
Short-circuit current	Max. 2 A
Load type	Ohmic, inductive Lamp load
Digital inputs (for customer interface X41)	6 (DI1 to DI6)
Signal voltage "0"	-3 V ... +5 V EN 61131-2, type 3
Signal voltage "1"	15 V ... 30 V EN 61131-2, type 3
Input current	typically 3 mA EN 61131-2, type 3
Input filter	typically 0.3 ms
Power supply	24 V / 3 A

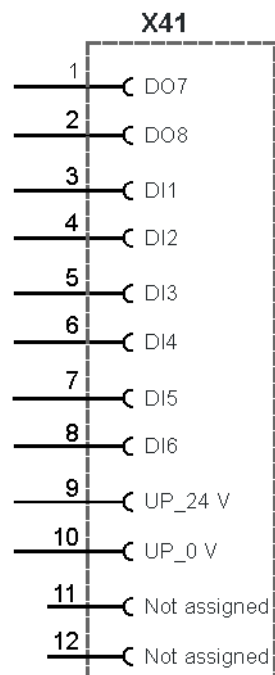

Fig. 6-11: Wiring diagram, connection X41

**Connection
XPN41**

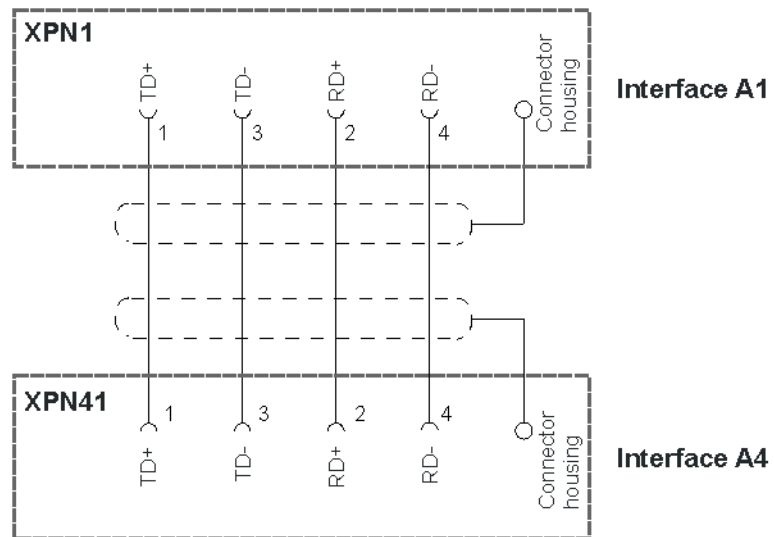

Fig. 6-12: Wiring diagram, connection XPN41

Connection AIR2

Customer-specific air connection with the following values:

Designation	Limit values
Max. pressure	7 bar
Vacuum	Atmospheric pressure minus 0.95 bar

7 Transportation

7.1 Transporting the manipulator

Description Move the robot into its transport position each time it is transported. It must be ensured that the robot is stable while it is being transported. The robot must remain in its transport position until it has been fastened to the foundation. Before the robot is lifted, it must be ensured that it is free from obstructions. Remove all transport safeguards, such as nails and screws, in advance. First remove any corrosion or glue on contact surfaces.

Transport position The robot must be in the transport position before it can be transported (>>> Fig. 7-1). The robot is in the transport position when the axes are in the following positions:

Axis	A1	A2	A3	A4	A5	A6
Angle	0°	-105°	+156°	0°	+120°	0°

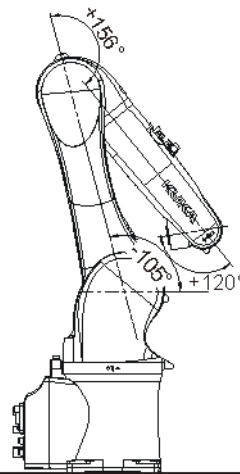

Fig. 7-1: Transport position

Transport dimensions The transport dimensions for the robot can be noted from the following figures. The position of the center of gravity and the weight vary according to the specific configuration. The specified dimensions refer to the robot without equipment.

The following transport dimensions (>>> Fig. 7-2) are valid for the robots:

- KR 6 R700 sixx
- KR 6 R700 sixx W
- KR 6 R700 sixx C

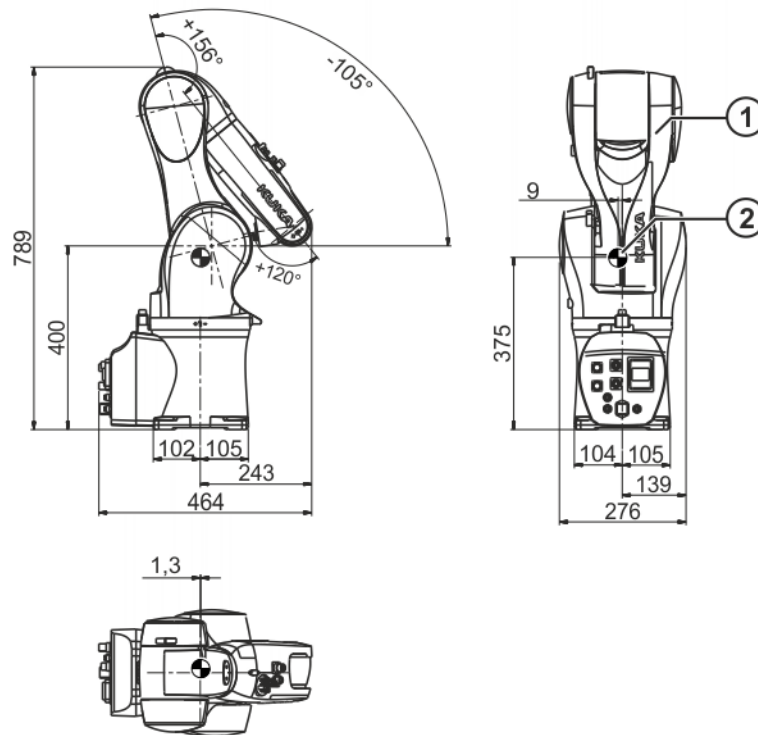

Fig. 7-2: Transport dimensions

1 Robot

2 Center of gravity

The following transport dimensions (>>> Fig. 7-3) are valid for the robots:

- KR 6 R900 sixx
- KR 6 R900 sixx W
- KR 6 R900 sixx C
- KR 10 R900 sixx
- KR 10 R900 sixx W
- KR 10 R900 sixx C

Maße / Dimensions: mm

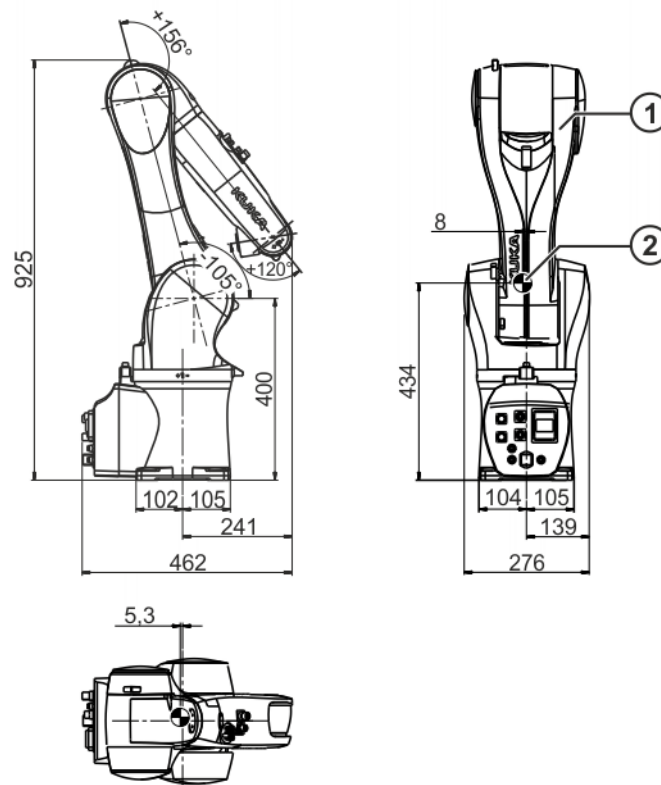

Fig. 7-3: Transport dimensions

1 Robot

2 Center of gravity

The following transport dimensions (>>> Fig. 7-4) are valid for the robots:

- KR 10 R1100 sixx
- KR 10 R1100 sixx W
- KR 10 R1100 sixx C

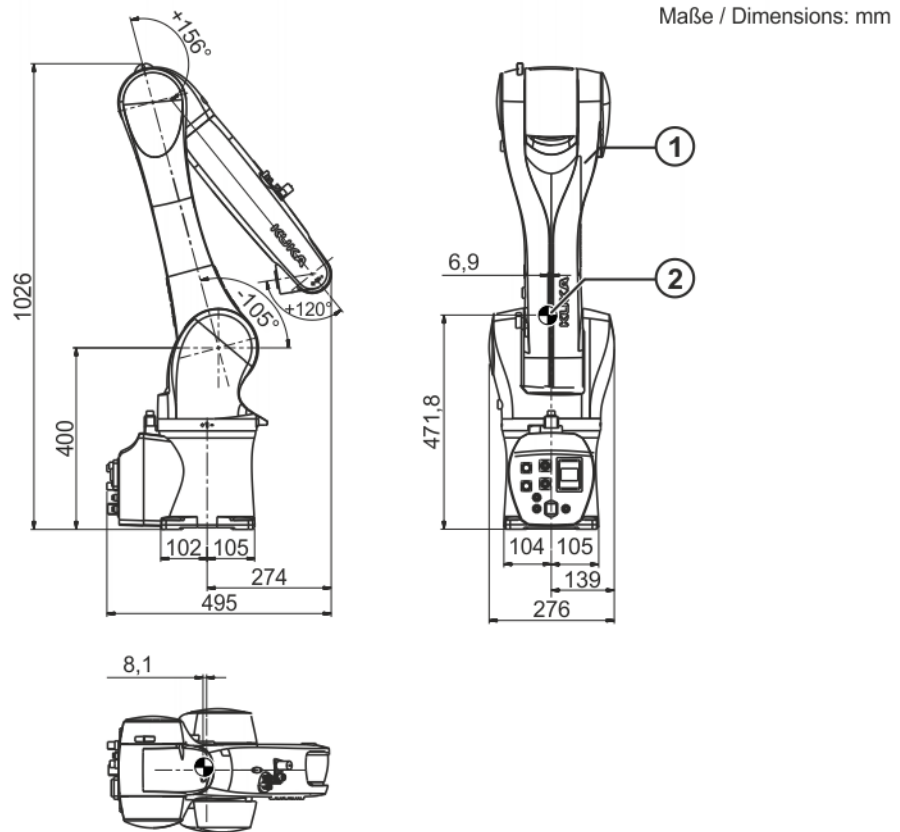

Fig. 7-4: Transport dimensions

1 Robot

2 Center of gravity

Transportation using lifting tackle

WARNING Use of unsuitable handling equipment may result in damage to the robot or injury to persons. Only use authorized handling equipment with a sufficient load-bearing capacity. Only transport the robot in the manner specified here.

The robot is transported using lifting tackle (>>> Fig. 7-5). The robot must be in the transport position. The loops of the lifting tackle are passed around the link arm and rotating column. All ropes must be long enough and must be routed in such a way that the robot is not damaged. Installed tools and pieces of equipment can cause undesirable shifts in the center of gravity.

WARNING The robot may tip during transportation. Risk of personal injury and damage to property. If the robot is being transported using lifting tackle, special care must be exercised to prevent it from tipping. Additional safeguarding measures must be taken. It is forbidden to pick up the robot in any other way using a crane!

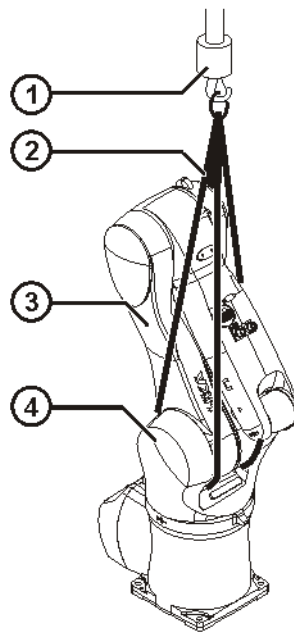

Fig. 7-5: Transportation using lifting tackle

- | | | | |
|---|----------------|---|-----------------|
| 1 | Crane | 3 | Link arm |
| 2 | Lifting tackle | 4 | Rotating column |

8 KUKA Service

8.1 Requesting support

Introduction The KUKA Roboter GmbH documentation offers information on operation and provides assistance with troubleshooting. For further assistance, please contact your local KUKA subsidiary.

Information The following information is required for processing a support request:

- Model and serial number of the manipulator
- Model and serial number of the controller
- Model and serial number of the linear unit (if applicable)
- Model and serial number of the energy supply system (if applicable)
- Version of the KUKA System Software
- Optional software or modifications
- Archive of the software
- Application used
- Any external axes used (if applicable)
- Description of the problem, duration and frequency of the fault

8.2 KUKA Customer Support

Availability KUKA Customer Support is available in many countries. Please do not hesitate to contact us if you have any questions.

Argentina Ruben Costantini S.A. (Agency)
Luis Angel Huergo 13 20
Parque Industrial
2400 San Francisco (CBA)
Argentina
Tel. +54 3564 421033
Fax +54 3564 428877
ventas@costantini-sa.com

Australia Headland Machinery Pty. Ltd.
Victoria (Head Office & Showroom)
95 Highbury Road
Burwood
Victoria 31 25
Australia
Tel. +61 3 9244-3500
Fax +61 3 9244-3501
vic@headland.com.au
www.headland.com.au

Belgium	KUKA Automatisering + Robots N.V. Centrum Zuid 1031 3530 Houthalen Belgium Tel. +32 11 516160 Fax +32 11 526794 info@kuka.be www.kuka.be
Brazil	KUKA Roboter do Brasil Ltda. Travessa Claudio Armando, nº 171 Bloco 5 - Galpões 51/52 Bairro Assunção CEP 09861-7630 São Bernardo do Campo - SP Brazil Tel. +55 11 4942-8299 Fax +55 11 2201-7883 info@kuka-roboter.com.br www.kuka-roboter.com.br
Chile	Robotec S.A. (Agency) Santiago de Chile Chile Tel. +56 2 331-5951 Fax +56 2 331-5952 robotec@robotec.cl www.robotec.cl
China	KUKA Robotics China Co.,Ltd. Songjiang Industrial Zone No. 388 Minshen Road 201612 Shanghai China Tel. +86 21 6787-1888 Fax +86 21 6787-1803 www.kuka-robotics.cn
Germany	KUKA Roboter GmbH Zugspitzstr. 140 86165 Augsburg Germany Tel. +49 821 797-4000 Fax +49 821 797-1616 info@kuka-roboter.de www.kuka-roboter.de

France KUKA Automatismes + Robotique SAS
Techvallée
6, Avenue du Parc
91140 Villebon S/Yvette
France
Tel. +33 1 6931660-0
Fax +33 1 6931660-1
commercial@kuka.fr
www.kuka.fr

India KUKA Robotics India Pvt. Ltd.
Office Number-7, German Centre,
Level 12, Building No. - 9B
DLF Cyber City Phase III
122 002 Gurgaon
Haryana
India
Tel. +91 124 4635774
Fax +91 124 4635773
info@kuka.in
www.kuka.in

Italy KUKA Roboter Italia S.p.A.
Via Pavia 9/a - int.6
10098 Rivoli (TO)
Italy
Tel. +39 011 959-5013
Fax +39 011 959-5141
kuka@kuka.it
www.kuka.it

Japan KUKA Robotics Japan K.K.
YBP Technical Center
134 Godo-cho, Hodogaya-ku
Yokohama, Kanagawa
240 0005
Japan
Tel. +81 45 744 7691
Fax +81 45 744 7696
info@kuka.co.jp

Canada KUKA Robotics Canada Ltd.
6710 Maritz Drive - Unit 4
Mississauga
L5W 0A1
Ontario
Canada
Tel. +1 905 670-8600
Fax +1 905 670-8604
info@kukarobotics.com
www.kuka-robotics.com/canada

Korea	KUKA Robotics Korea Co. Ltd. RIT Center 306, Gyeonggi Technopark 1271-11 Sa 3-dong, Sangnok-gu Ansan City, Gyeonggi Do 426-901 Korea Tel. +82 31 501-1451 Fax +82 31 501-1461 info@kukakorea.com
Malaysia	KUKA Robot Automation Sdn Bhd South East Asia Regional Office No. 24, Jalan TPP 1/10 Taman Industri Puchong 47100 Puchong Selangor Malaysia Tel. +60 3 8061-0613 or -0614 Fax +60 3 8061-7386 info@kuka.com.my
Mexico	KUKA de México S. de R.L. de C.V. Progreso #8 Col. Centro Industrial Puente de Vigas Tlalnepantla de Baz 54020 Estado de México Mexico Tel. +52 55 5203-8407 Fax +52 55 5203-8148 info@kuka.com.mx www.kuka-robotics.com/mexico
Norway	KUKA Sveiseanlegg + Roboter Sentrumsvegen 5 2867 Hov Norway Tel. +47 61 18 91 30 Fax +47 61 18 62 00 info@kuka.no
Austria	KUKA Roboter Austria GmbH Vertriebsbüro Österreich Regensburger Strasse 9/1 4020 Linz Austria Tel. +43 732 784752 Fax +43 732 793880 office@kuka-roboter.at www.kuka-roboter.at

Poland KUKA Roboter Austria GmbH
Spółka z ograniczoną odpowiedzialnością
Oddział w Polsce
Ul. Porcelanowa 10
40-246 Katowice
Poland
Tel. +48 327 30 32 13 or -14
Fax +48 327 30 32 26
ServicePL@kuka-roboter.de

Portugal KUKA Sistemas de Automatización S.A.
Rua do Alto da Guerra n° 50
Armazém 04
2910 011 Setúbal
Portugal
Tel. +351 265 729780
Fax +351 265 729782
kuka@mail.telepac.pt

Russia OOO KUKA Robotics Rus
Webnaja ul. 8A
107143 Moskau
Russia
Tel. +7 495 781-31-20
Fax +7 495 781-31-19
kuka-robotics.ru

Sweden KUKA Svetsanläggningar + Robotar AB
A. Odhners gata 15
421 30 Västra Frölunda
Sweden
Tel. +46 31 7266-200
Fax +46 31 7266-201
info@kuka.se

Switzerland KUKA Roboter Schweiz AG
Industriestr. 9
5432 Neuenhof
Switzerland
Tel. +41 44 74490-90
Fax +41 44 74490-91
info@kuka-roboter.ch
www.kuka-roboter.ch

Spain	KUKA Robots IBÉRICA, S.A. Pol. Industrial Torrent de la Pastera Carrer del Bages s/n 08800 Vilanova i la Geltrú (Barcelona) Spain Tel. +34 93 8142-353 Fax +34 93 8142-950 Comercial@kuka-e.com www.kuka-e.com
South Africa	Jendamark Automation LTD (Agency) 76a York Road North End 6000 Port Elizabeth South Africa Tel. +27 41 391 4700 Fax +27 41 373 3869 www.jendamark.co.za
Taiwan	KUKA Robot Automation Taiwan Co., Ltd. No. 249 Pujong Road Jungli City, Taoyuan County 320 Taiwan, R. O. C. Tel. +886 3 4331988 Fax +886 3 4331948 info@kuka.com.tw www.kuka.com.tw
Thailand	KUKA Robot Automation (M)SdnBhd Thailand Office c/o Maccall System Co. Ltd. 49/9-10 Soi Kingkaew 30 Kingkaew Road Tt. Rachatheva, A. Bangpli Samutprakarn 10540 Thailand Tel. +66 2 7502737 Fax +66 2 6612355 atika@ji-net.com www.kuka-roboter.de
Czech Republic	KUKA Roboter Austria GmbH Organisation Tschechien und Slowakei Sezemická 2757/2 193 00 Praha Horní Počernice Czech Republic Tel. +420 22 62 12 27 2 Fax +420 22 62 12 27 0 support@kuka.cz

Hungary KUKA Robotics Hungaria Kft.
Fő út 140
2335 Taksony
Hungary
Tel. +36 24 501609
Fax +36 24 477031
info@kuka-robotics.hu

USA KUKA Robotics Corporation
51870 Shelby Parkway
Shelby Township
48315-1787
Michigan
USA
Tel. +1 866 873-5852
Fax +1 866 329-5852
info@kukarobotics.com
www.kukarobotics.com

UK KUKA Automation + Robotics
Hereward Rise
Halesowen
B62 8AN
UK
Tel. +44 121 585-0800
Fax +44 121 585-0900
sales@kuka.co.uk

Index

Numbers

2004/108/EC 99
 2006/42/EC 99
 89/336/EEC 99
 95/16/EC 99
 97/23/EC 100

A

Accessories 9, 87
 Altitude 15, 31
 Ambient conditions 15, 31
 Ambient temperature, operation 15, 31
 Ambient temperature, storage 15, 31
 Ambient temperature, transportation 15, 31
 Angle of rotation 50
 Applied norms and regulations 99
 Automatic mode 97
 Axes, number 14, 30
 Axis data, KR 10 sixx 32
 Axis data, KR 6 sixx 16
 Axis range 89
 Axis range limitation 92
 Axis range monitoring 93

B

Basic data, KR 10 sixx 30
 Basic data, KR 6 sixx 14
 Brake defect 94
 Brake release device 93
 Braking distance 89

C

CE mark 88
 Cleaning work 98
 Connecting cables 9, 15, 31, 87, 104
 Counterbalancing system 99
 Customer interfaces 105

D

Danger zone 89
 Declaration of conformity 88
 Declaration of incorporation 87, 88
 Decommissioning 99
 Description, manipulator 10
 Disposal 99
 Documentation, industrial robot 5
 Dynamic principal loads 15, 31

E

EC declaration of conformity 88
 EMC Directive 88, 99
 EN 60204-1 100
 EN 61000-6-2 100
 EN 61000-6-4 100
 EN 614-1 100
 EN ISO 10218-1 100
 EN ISO 12100 100
 EN ISO 13849-1 100

EN ISO 13849-2 100
 EN ISO 13850 100
 Extension 50
 External axes 87, 90

F

Faults 95
 Function test 96

G

Gear unit temperatures 15, 31
 General information 49
 General safety measures 94

H

Handling equipment 114
 Hazardous substances 99

I

Industrial robot 87
 Intended use 88
 Interface A1 105
 Interfaces 104
 Introduction 5
 ISO 9283, repeatability 14, 30

K

KCP 89, 94
 KCP, KUKA Control Panel 50
 Keyboard, external 95
 KL 5
 KUKA Customer Support 117
 KUKA smartPAD 89

L

Labeling 94
 Liability 87
 Linear unit 87
 Low Voltage Directive 88

M

Machine data 96
 Machine frame mounting 103
 Machinery Directive 88, 99
 main axes 49
 Maintenance 98
 Manipulator 9, 87, 89, 92
 Manual mode 97
 Mechanical axis range limitation 92
 Mechanical end stops 92
 MEMD 5
 Mounting base 101
 Mounting base data, KR 10 sixx 47
 Mounting base data, KR 6 sixx 29
 Mounting position 15, 31
 Mouse, external 95

O

Operator 89, 90
 Options 9, 87
 Overload 94
 Overview of the robot system 9

P

Payload diagram 24, 41
 Payloads, KR 10 sixx 41
 Payloads, KR 6 sixx 24
 Personnel 90
 Plant integrator 89
 Plates and labels 48
 Positioner 87
 Pressure Equipment Directive 99, 100
 Preventive maintenance work 98
 Product description 9
 Program override, motion velocity 50
 Protection classification, in-line wrist 15, 31
 Protection classification, robot 15, 31
 Protective equipment, overview 92
 Purpose 7

R

RDC 6
 Reaction distance 89
 Recommissioning 96
 Reference point 14, 30
 Relative air humidity 15, 31
 Release device 93
 Repair 98
 Repeatability 14, 30
 Robot controller 9, 87

S

Safety 87
 Safety instructions 5
 Safety zone 89, 91, 92
 Safety, general 87
 Service life 89
 Service, KUKA Roboter 117
 smartPAD 6, 9, 89
 Software 9, 87
 Sound level 15, 31
 Standard colors 15, 31
 Start-up 96
 STOP 0 50, 89
 STOP 1 50, 89
 STOP 2 89
 Stop category 0 89
 Stop category 1 89
 Stop category 2 89
 Stop signal 49
 Stopping distance 49, 89, 92
 Stopping distances 49
 Stopping distances, KR 10 R1100 sixx 74
 Stopping distances, KR 10 R1100 sixx C 74
 Stopping distances, KR 10 R1100 sixx W 80
 Stopping distances, KR 10 R900 sixx 74
 Stopping distances, KR 10 R900 sixx C 74
 Stopping distances, KR 10 R900 sixx W 80

Stopping distances, KR 6 R700 sixx 51
 Stopping distances, KR 6 R700 sixx C 51
 Stopping distances, KR 6 R700 sixx W 56
 Stopping distances, KR 6 R900 sixx 62
 Stopping distances, KR 6 R900 sixx C 62
 Stopping distances, KR 6 R900 sixx W 68
 Stopping time 49
 Stopping times 49
 Stopping times, KR 10 R1100 sixx 74
 Stopping times, KR 10 R1100 sixx C 74
 Stopping times, KR 10 R1100 sixx W 80
 Stopping times, KR 10 R900 sixx 74
 Stopping times, KR 10 R900 sixx C 74
 Stopping times, KR 10 R900 sixx W 80
 Stopping times, KR 6 R700 sixx 51
 Stopping times, KR 6 R700 sixx C 51
 Stopping times, KR 6 R700 sixx W 56
 Stopping times, KR 6 R900 sixx 62
 Stopping times, KR 6 R900 sixx C 62
 Stopping times, KR 6 R900 sixx W 68
 Storage 99
 Support request 117
 System integrator 88, 89, 90

T

T1 89
 T2 90
 Teach pendant 9, 87
 Technical data 13
 Terms used 5, 50
 Terms used, safety 89
 Training 7
 Transport position 111
 Transportation 95, 111
 Turn-tilt table 87

U

Use, contrary to intended use 87
 Use, improper 87
 User 89, 90
 Users 7

V

Volume of working envelope 14, 30

W

Warnings 5
 Weight 15, 31
 Working envelope 17, 33
 Working range limitation 92
 Workspace 89, 91, 92

