



Robots

KUKA Roboter GmbH

KR 5 sixx R650, R850 CR

Specification

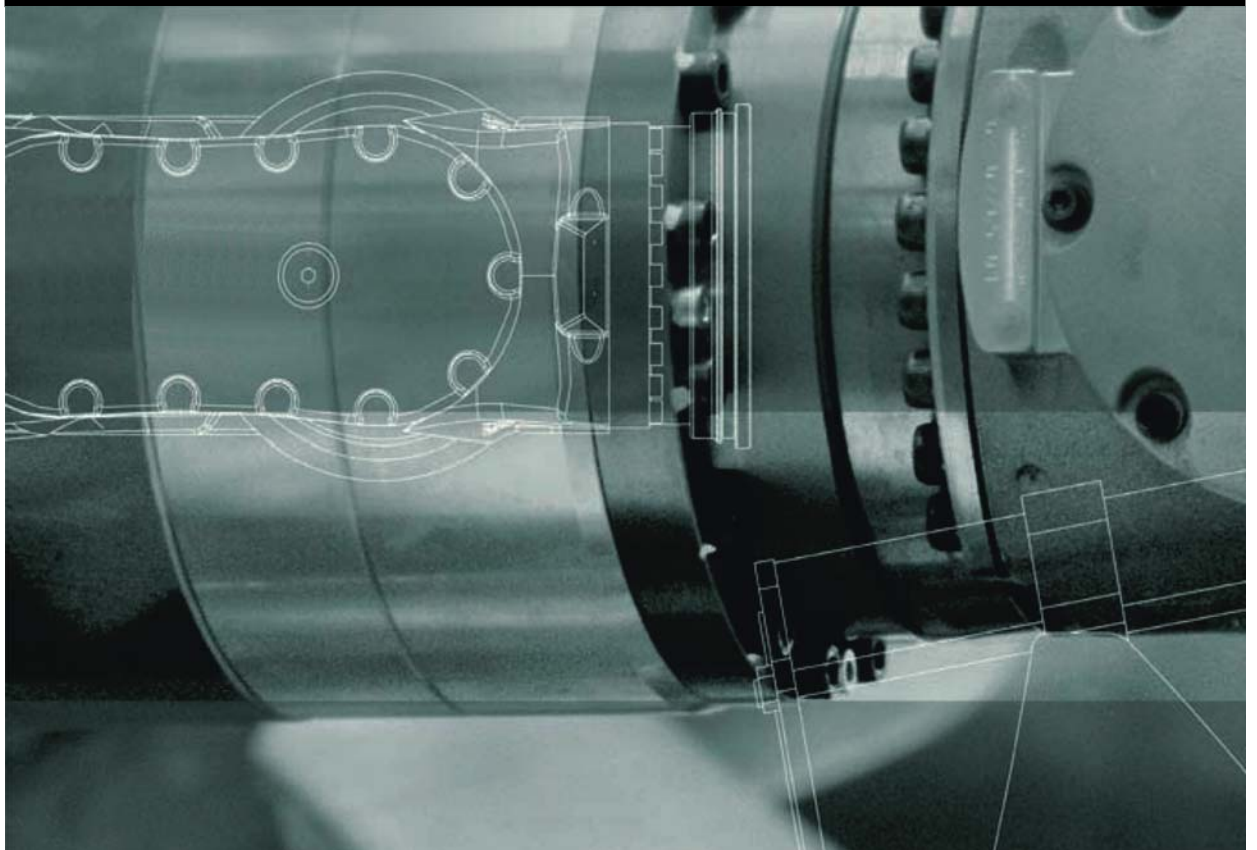

Issued: 19.07.2011

Version: Spez KR 5 sixx CR V4 en



© Copyright 2011

KUKA Roboter GmbH
Zugspitzstraße 140
D-86165 Augsburg
Germany

This documentation or excerpts therefrom may not be reproduced or disclosed to third parties without the express permission of KUKA Roboter GmbH.

Other functions not described in this documentation may be operable in the controller. The user has no claims to these functions, however, in the case of a replacement or service work.

We have checked the content of this documentation for conformity with the hardware and software described. Nevertheless, discrepancies cannot be precluded, for which reason we are not able to guarantee total conformity. The information in this documentation is checked on a regular basis, however, and necessary corrections will be incorporated in the subsequent edition.

Subject to technical alterations without an effect on the function.

Translation of the original documentation

KIM-PS5-DOC

Publication:	Pub Spez KR 5 sixx CR en
Bookstructure:	Spez KR 5 sixx CR V4.1
Label:	Spez KR 5 sixx CR V4 en

Contents

1	Product description	5
1.1	Overview of the robot system	5
1.2	Description of the robot	5
2	Technical data	7
2.1	Basic data	7
2.2	Axis data	8
2.3	Payloads	12
2.3.1	Mounting flange	13
2.4	Loads acting on the foundation	14
2.5	Additional data	15
2.6	Valve assembly	16
2.7	Plates and labels	18
3	Safety	21
3.1	General	21
3.1.1	Liability	21
3.1.2	Intended use of the industrial robot	21
3.1.3	EC declaration of conformity and declaration of incorporation	22
3.1.4	Terms used	23
3.2	Personnel	23
3.3	Workspace, safety zone and danger zone	25
3.4	Triggers for stop reactions	25
3.5	Safety functions	26
3.5.1	Overview of safety functions	26
3.5.2	ESC safety logic	26
3.5.3	Mode selector switch	27
3.5.4	Operator safety	28
3.5.5	EMERGENCY STOP device	28
3.5.6	External EMERGENCY STOP device	29
3.5.7	Enabling device	29
3.6	Additional protective equipment	30
3.6.1	Jog mode	30
3.6.2	Software limit switches	31
3.6.3	Labeling on the industrial robot	31
3.6.4	External safeguards	31
3.7	Overview of operating modes and safety functions	32
3.8	Safety measures	32
3.8.1	General safety measures	32
3.8.2	Transportation	33
3.8.3	Start-up and recommissioning	34
3.8.4	Virus protection and network security	35
3.8.5	Manual mode	36
3.8.6	Simulation	36
3.8.7	Automatic mode	37
3.8.8	Maintenance and repair	37
3.8.9	Decommissioning, storage and disposal	38

3.8.10	Safety measures for “single point of control”	38
3.9	Applied norms and regulations	39
4	Planning	41
4.1	Mounting base	41
4.2	Instructions for mechanical axis range limitation	41
4.2.1	Instructions for mechanical axis range limitation on A1	42
4.2.2	Instructions for mechanical axis range limitation on A2	43
4.2.3	KR 5 sixx R650: instructions for mechanical axis range limitation on A3	44
4.2.4	KR 5 sixx R850: instructions for mechanical axis range limitation on A3	45
5	Transportation	47
5.1	Transporting the robot	47
6	Appendix	51
6.1	Mechanical axis range limitation on axis 1, dimensioned drawings	51
6.2	Mechanical axis range limitation on axis 2, dimensioned drawings	52
6.3	KR 5 sixx R650: mechanical axis range limitation on axis 3, dimensioned drawings	53
6.4	KR 5 sixx R850: mechanical axis range limitation on axis 3, dimensioned drawings	55
7	KUKA Service	57
7.1	Requesting support	57
7.2	KUKA Customer Support	57
	Index	65

1 Product description

1.1 Overview of the robot system

The robot system consists of the following components:

- Manipulator
- Robot controller
- KCP teach pendant
- Connecting cables
- Software
- Options, accessories



Fig. 1-1: Example of a robot system

- | | |
|--------------------|-----------------------|
| 1 Robot | 3 Teach pendant (KCP) |
| 2 Robot controller | 4 Connecting cables |

1.2 Description of the robot

Overview

The robot is a 6-axis jointed-arm robot made of cast light alloy. All motor units and current-carrying cables are protected against dirt and moisture beneath screwed-on cover plates.

The robot consists of the following principal components:

- In-line wrist
- Arm
- Link arm
- Rotating column
- Base frame
- Electrical installations

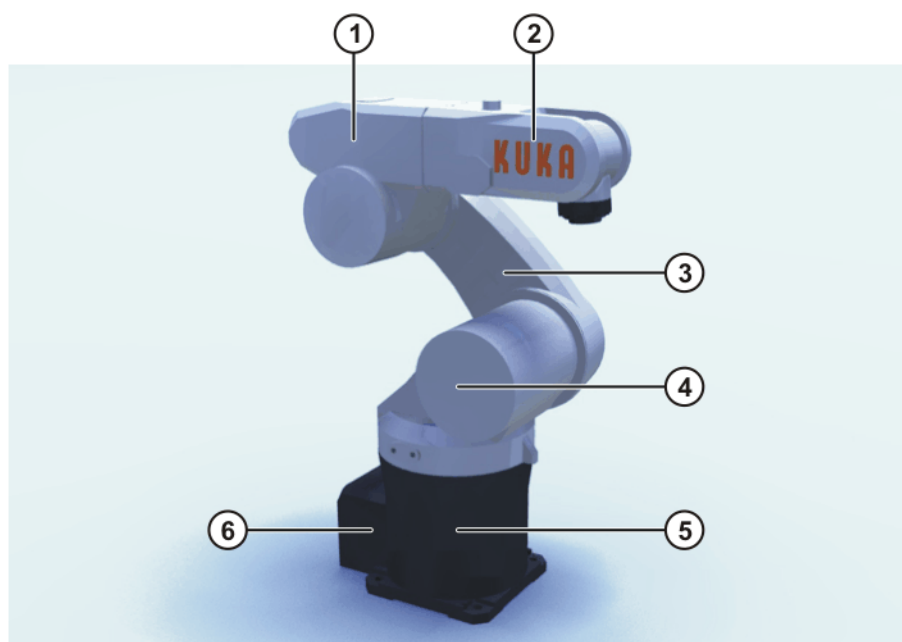

Fig. 1-2: Principal components

1	Arm	4	Rotating column
2	In-line wrist	5	Base frame
3	Link arm	6	Electrical installations

In-line wrist

The robot is fitted with a 3-axis in-line wrist. It is driven by the motors in the arm (axis 4) and in-line wrist. The motor of axis 4 drives the gear unit directly, while axes 5 and 6 are additionally driven by means of a toothed belt. The in-line wrist performs the motions about axes 4, 5 and 6.

There are three 5/2 pulse valves in the in-line wrist that can be used for controlling tools. The description and the data of the valve group are given in the section "Technical data" (>>> 2.6 "Valve assembly" Page 16).

The in-line wrist also accommodates the 10-contact circular connector of the wrist I/O cable.

Arm

The arm is the link between the in-line wrist and the link arm. It houses the motor of wrist axis 4. There are 2 variants of arm available.

Link arm

The link arm is installed between the arm and the rotating column. It houses the motors and gear units of axes 2 and 3. The supply lines of the energy supply system and cable harness for axes 2 to 6 are routed through the link arm. There are 2 variants of link arm available.

Rotating column

The rotational motions of axis 1 are performed by the rotating column. This is screwed to the base frame via the gear unit of axis 1 and is driven by a motor in the base frame. The rotating column houses the backup batteries for backing up the axis data of the position sensing system.

Base frame

The base frame is the base of the robot. It constitutes the interface for the connecting cables between the robot, the controller and the energy supply system. All connecting cables are accommodated at the rear of the base frame.

2 Technical data

2.1 Basic data

Basic data

Type	KR 5 sixx R650 CR KR 5 sixx R850 CR
Number of axes	6
Volume of working envelope	KR 5 sixx R650 CR: 1.0 m ³ KR 5 sixx R850 CR: 2.3 m ³
Repeatability (ISO 9283)	KR 5 sixx R650 CR: ±0.02 mm KR 5 sixx R850 CR: ±0.03 mm
Working envelope reference point	Intersection of axes 4 and 5
Weight	KR 5 sixx R650 CR: approx. 28 kg KR 5 sixx R850 CR: approx. 29 kg
Principal dynamic loads	See "Loads acting on the mounting base"
Protection classification of the robot	IP 54, ready for operation, with connecting cables plugged in (according to EN 60529)
Protection classification of the in-line wrist	IP 65
Air cleanliness classes	Class 3 with extraction system at 40% and 80% override (acc. to EN ISO 14644-1) Class 4 without extraction system at 40% and 80% override (acc. to EN ISO 14644-1)
Sound level	< 75 dB (A) outside the working envelope
Mounting position	Floor or ceiling
Surface finish, paintwork	Plastic: white, paintwork: white, base frame: black

Vibration stress

Operation	No permanent vibration stress permissible Brief, one-off: 0.5 g
Storage and transportation	Brief, one-off: 3 g

Ambient temperature

Operation	0 °C to +40 °C (273 K to 313 K) Relative air humidity ≤ 90% No condensation permissible.
Storage and transportation	-10 °C to +60 °C (263 K to 333 K) Relative air humidity ≤ 75% No condensation permissible.

Ambient conditions

Operation	<ul style="list-style-type: none"> ■ Free from inflammable dust, gases and liquids ■ Free from aggressive and corrosive gases and liquids ■ Free from flying parts ■ Free from spraying liquids ■ Free from electromagnetic loads, e.g. from welding equipment or high-frequency converters
------------------	------------------------------------------------------------------------------------------------------------------------------------------------------------------------------------------------------------------------------------------------------------------------------------------------------------------------------------------------

Connecting cables

Cable lengths: 4 m, 6 m, 12 m

The connecting cables consist of the motor/data cable and the wrist I/O cable. The following connector designations and connections are used:

Cable designation	Connector designation	Robot controller - Robot
Motor/data cable	X20 - CN22	Harting circular connector
Wrist I/O cable	X32 - CN20	D-Sub circular connector
Ground conductor	PE	M5 cable lug at each end

For detailed specifications of the connecting cables, see

2.2 Axis data

The data are valid for floor-mounted R650 and R850 robots.

Axis data

Axis	Range of motion, software-limited	Speed with rated payload 5 kg
1	+/-170°	375 °/s with R650 250 °/s with R850
2	+45° to -190°	300 °/s with R650 250 °/s with R850
3	+165° to -119°	375 °/s with R650 250 °/s with R850
4	+/-190°	410°/s
5	+/-120°	410°/s
6	+/-358 °	660°/s

The direction of motion and the arrangement of the individual axes may be noted from the following diagram.

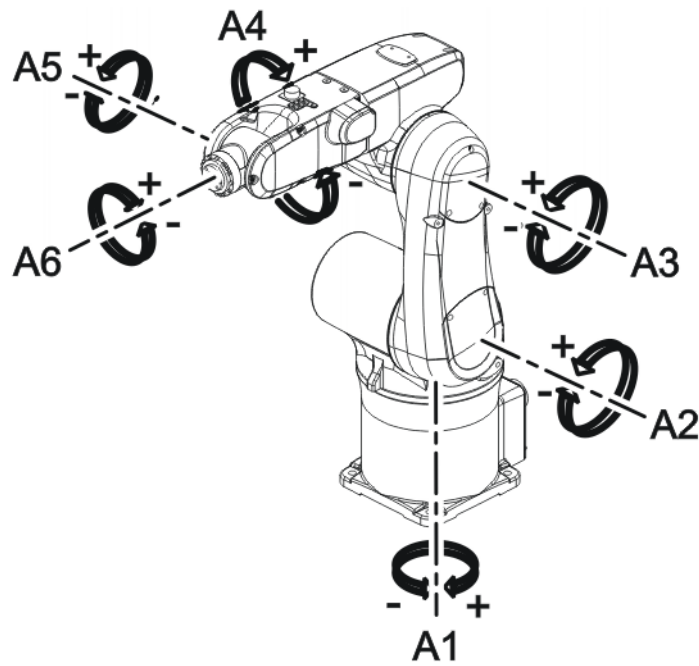

Fig. 2-1: Robot axes

Working envelope

The following diagram shows the shape and size of the working envelope.

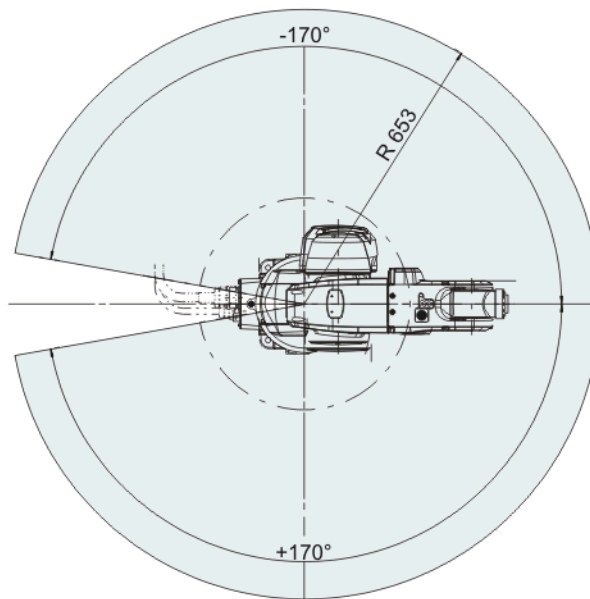
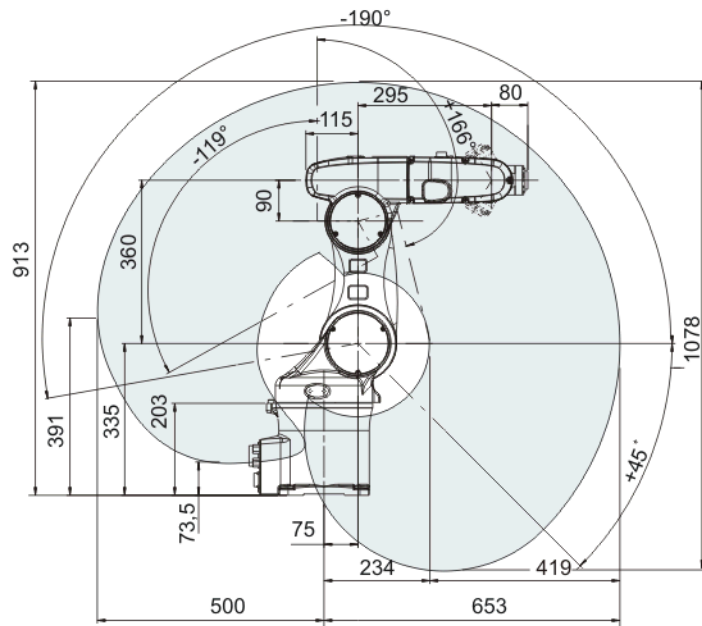

Fig. 2-2: Working envelope R650

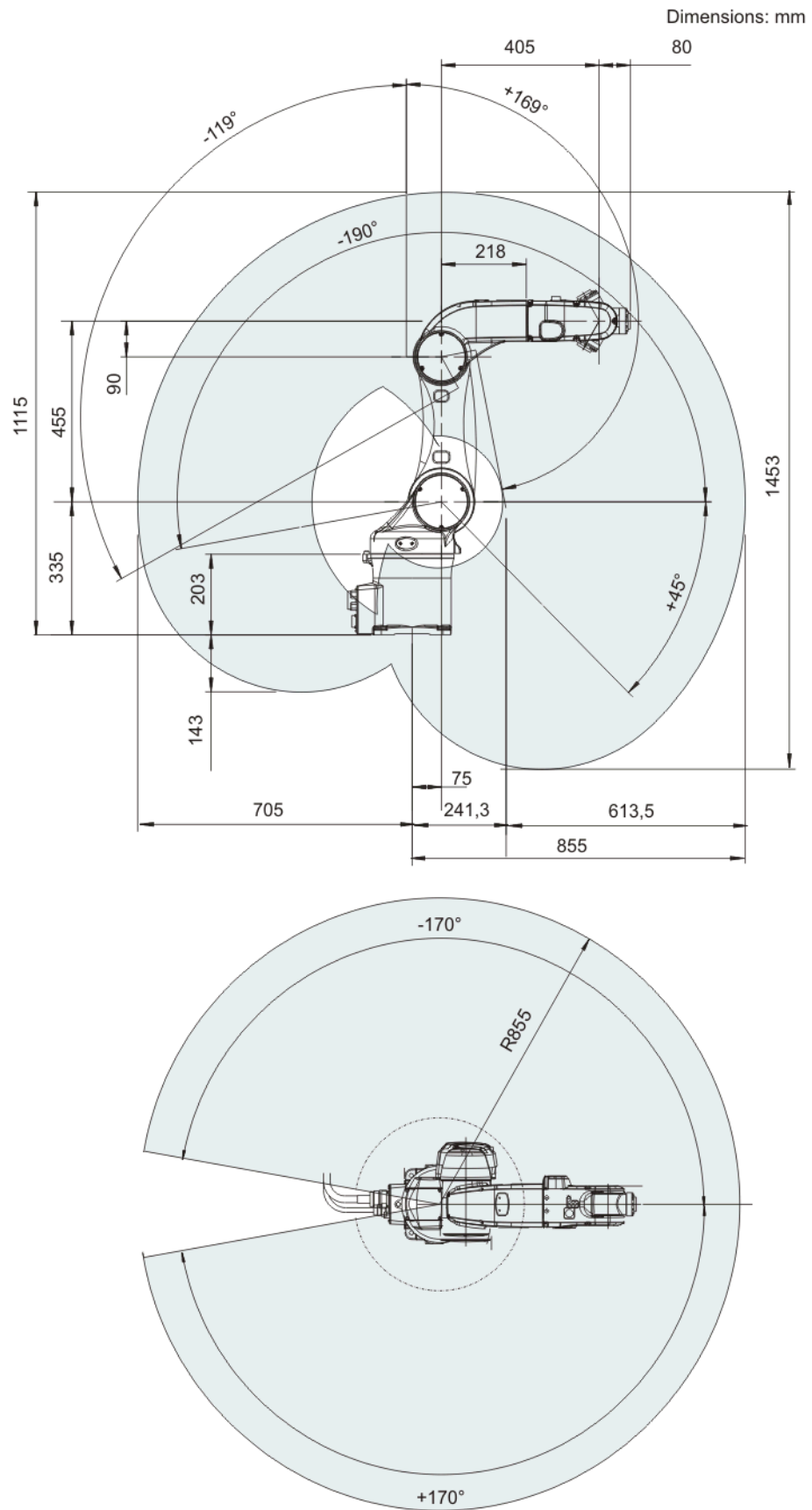

Fig. 2-3: Working envelope R850

2.3 Payloads

Payloads

Robot	KR 5 sixx CR
In-line wrist	IW 5
Rated payload	5 kg
Distance of the load center of gravity L_x	80 mm
Distance of the load center of gravity L_y	0 mm
Distance of the load center of gravity L_z	150 mm
Max. total load	5 kg

Load center of gravity P

For all payloads, the load center of gravity refers to the distance from the face of the mounting flange on axis 6. Refer to the payload diagram for the nominal distance.

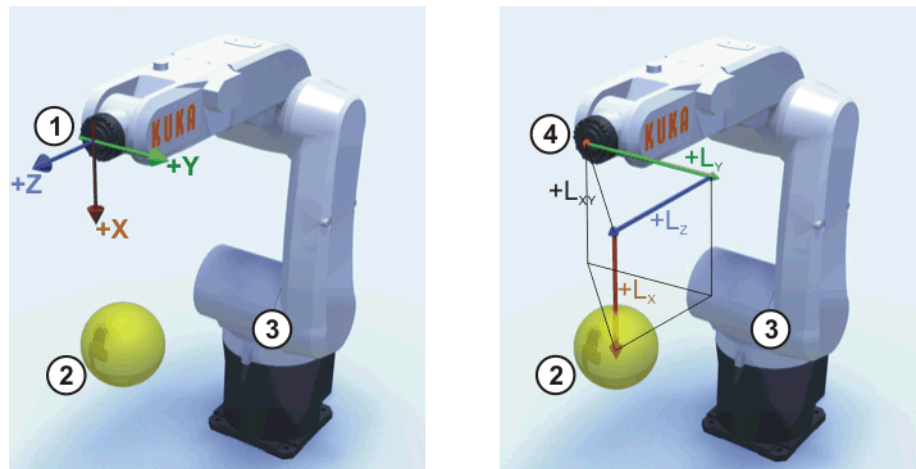

Fig. 2-4: Payload on the robot

- 1 FLANGE coordinate system
- 2 Load center of gravity
- 3 Robot
- 4 Distances L_x , L_y , L_z of the load center of gravity

Payload diagram

Permissible mass inertia at the design point (L_x , L_y , L_z) is 0.045 kgm².

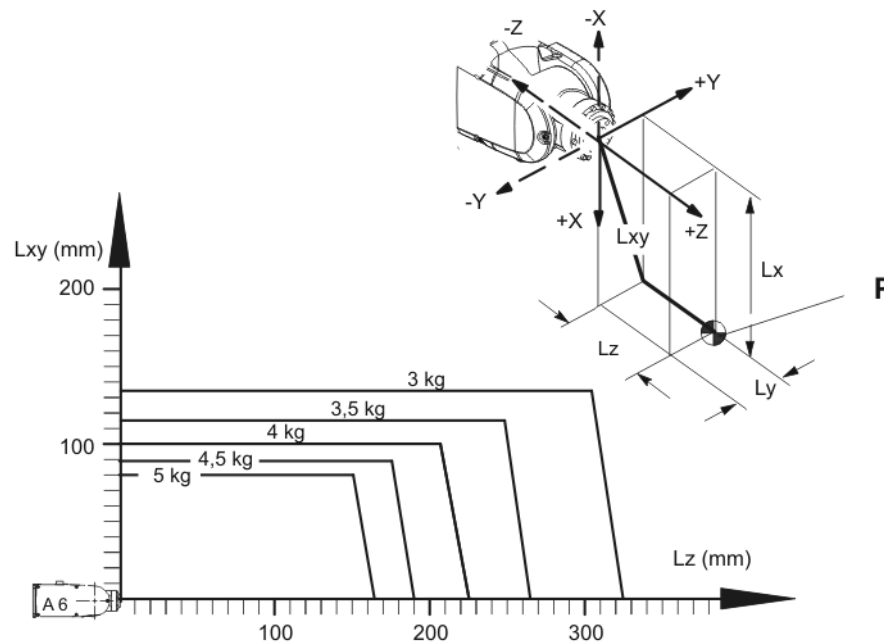

Fig. 2-5: Payload diagram

NOTICE

This loading curve corresponds to the maximum load capacity. Both values (payload and mass moment of inertia) must be checked in all cases. Exceeding this capacity will reduce the service life of the robot and overload the motors and the gears; in any such case the KUKA Roboter GmbH must be consulted beforehand. The values determined here are necessary for planning the robot application. For commissioning the robot, additional input data are required in accordance with operating and programming instructions of the KUKA System Software. The mass inertia must be verified using KUKA.Load. It is imperative for the load data to be entered in the robot controller!

Supplementary load

The robot cannot carry supplementary loads.

2.3.1 Mounting flange

The mounting flange is included in the scope of supply of the robot.

Mounting flange	DIN/ISO 9409-1-A31,5
Strength class	10.9
Screw size	M5
Grip length	1.5 x nominal diameter
Depth of engagement	min. 6 mm, max. 8 mm
Locating element	5 H7

The mounting flange is depicted (>>> Fig. 2-6) with axes 4 and 5 in the zero position. The symbol X_m indicates the position of the locating element (bushing) in the zero position.

Dimensions: mm

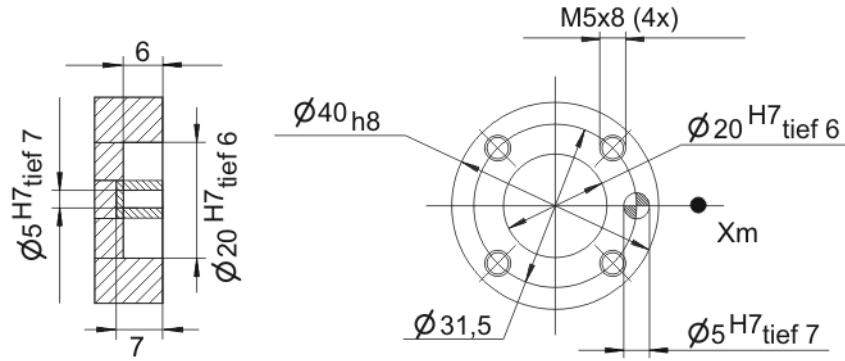

Fig. 2-6: Mounting flange

2.4 Loads acting on the foundation

Loads acting on the foundation

The specified forces and moments already include the payload and the inertia force (weight) of the robot.

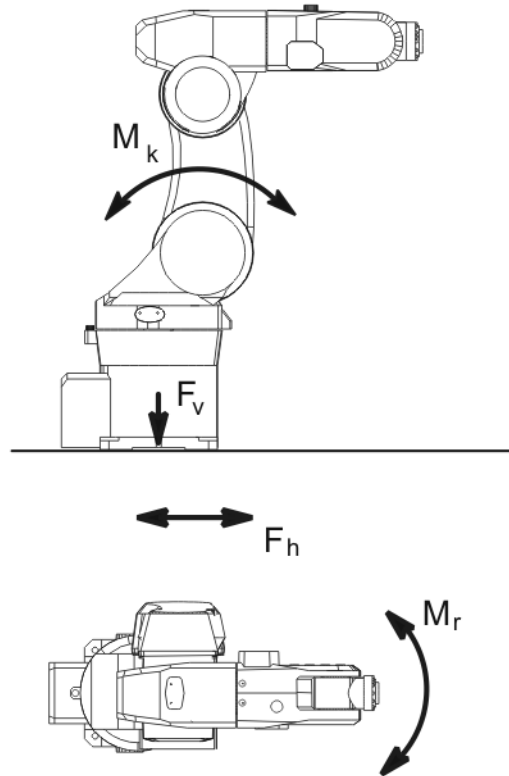

Fig. 2-7: Loads acting on the mounting base

Type of load	Force/torque/mass
F_v = vertical force	$F_{vmax} = 1,000 \text{ N}$
F_h = horizontal force	$F_{hmax} = 1,050 \text{ N}$ with R650 $F_{hmax} = 850 \text{ N}$ with R850
M_k = tilting moment	$M_{kmax} = 1,000 \text{ Nm}$ with R650 $M_{kmax} = 1,100 \text{ Nm}$ with R850

Type of load	Force/torque/mass
$M_r = \text{torque}$	$M_{r\max} = 1,100 \text{ Nm}$
Total mass for load acting on the mounting base	33 kg with R650 34 kg with R850
Robot	28 kg with R650 29 kg with R850
Total load (suppl. load on arm + rated payload)	5 kg

2.5 Additional data

Accessories Only accessories authorized and offered by KUKA may be used for this robot. All items of equipment must possess the appropriate certification and declarations of conformity.

Fastening threads The fastening holes serve for fastening the covers, axis range limitations or cable harnesses.

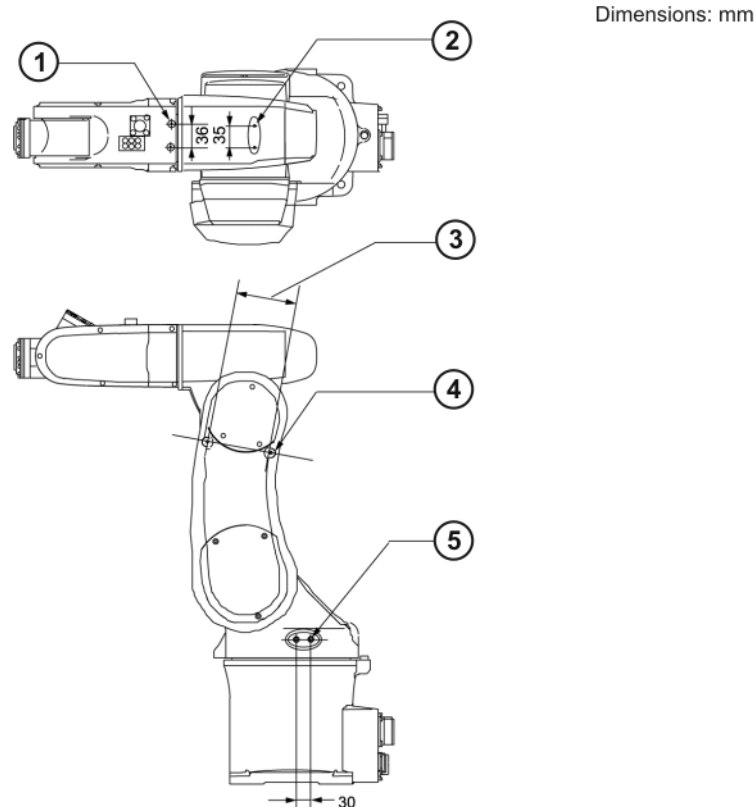

Fig. 2-8: Fastening threads

- 1 2 holes, M3, 7 mm deep
- 2 2 holes, M4, 16 mm deep
- 3 2 holes, M3, 7 mm deep; distance 104.5 mm
- 4 2 holes, M5, 12 mm deep
- 5 2 holes, M8, 25 mm deep (transportation)

2.6 Valve assembly

The robot has three 5/2-way valves integrated into the in-line wrist. The valve assembly is activated via the internal energy supply system.

Designation	Limit values
Valve type	5/2 pulse valve
Operating pressure, infeed	0.1 to 0.39 MPa
Max. pressure	0.49 MPa
Switching frequency	10 Hz
Operating temperature	-5 °C to 50 °C (268 K to 323 K) condensation-free
Threaded union	M5 PT1/4
Media	Air, oil-free
Operating voltage	24 V \pm 10%
Current	0.5 W, 21 mA



For the valve assembly with the corresponding threaded union PT1/4 or PT1/8, a universal plug-in connection with the designation KQ is required. This is supplied exclusively by SMC.

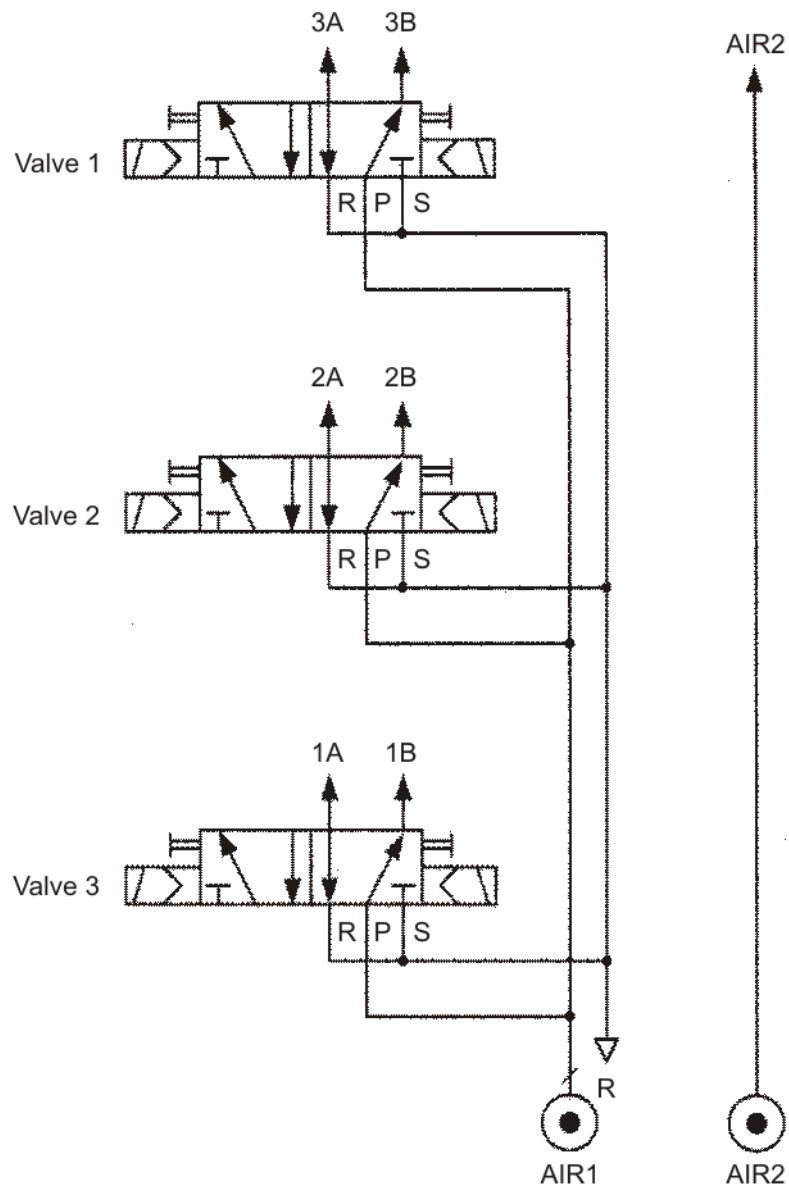

Fig. 2-9: Valve diagram

Signal	Connector X32	Connector CN20	Valve connector	Description
N. C.	Pin 8	Pin M	Pin 1	0 V internal
\$OUT9	Pin 1	Pin N	Pin 2	Valve 1 - position A
\$OUT10	Pin 14	Pin T	Pin 6	Valve 3 - position A
\$OUT11	Pin 2	Pin P	Pin 3	Valve 1 - position B
\$OUT12	Pin 15	Pin U	Pin 7	Valve 3 - position B
\$OUT13	Pin 3	Pin R	Pin 4	Valve 2 - position A
\$OUT15	Pin 4	Pin S	Pin 5	Valve 2 - position B

2.7 Plates and labels

Plates and labels The following plates and labels are supplied with the robot. It is left to the customer to decide whether to attach these plates and labels. The exception to this is the rating plate. This must be attached, if necessary on the control cabinet.

If the plates and labels are attached to the robot, they must not be removed or rendered illegible. Illegible plates, labels and signs must be replaced.

Information about attaching the plates and labels is given in the following illustrations:

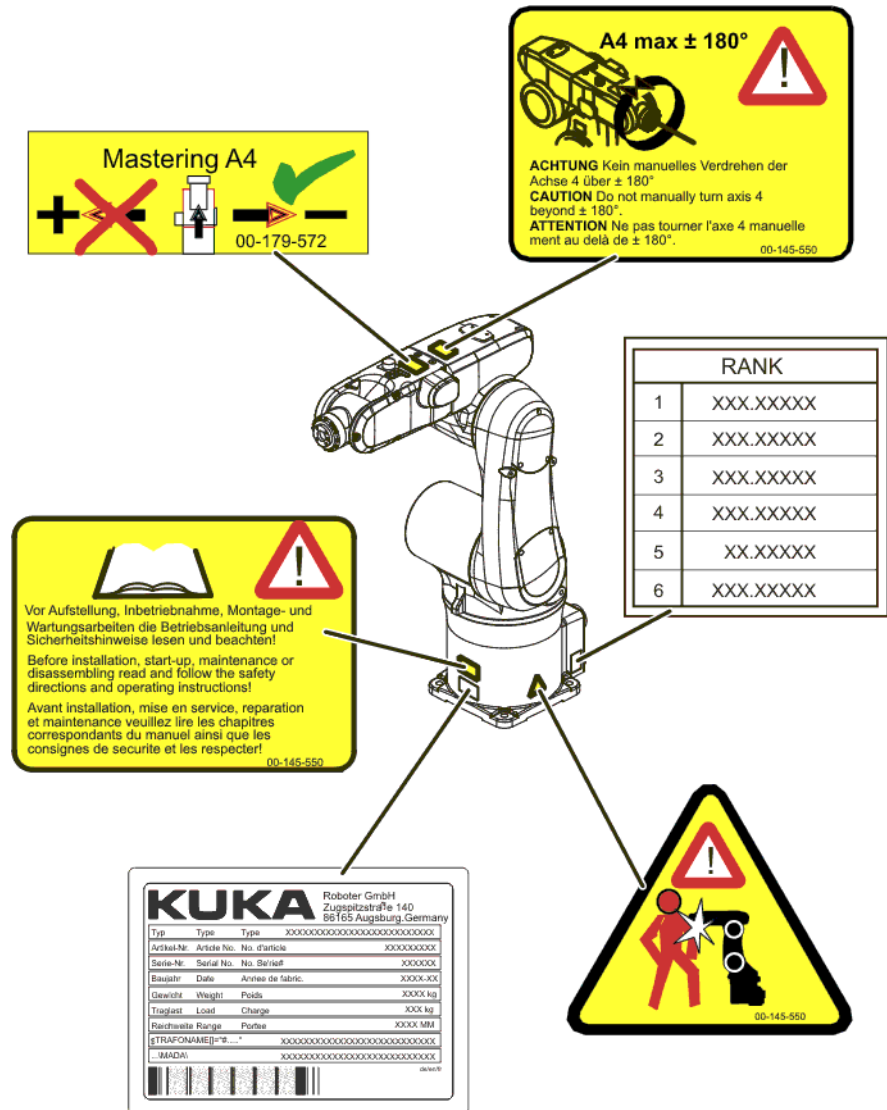

Fig. 2-10: Plates and labels



Fig. 2-11: Design label, KR 5 sixx CR

3 Safety

3.1 General

3.1.1 Liability

The device described in this document is either an industrial robot or a component thereof.

Components of the industrial robot:

- Manipulator
- Robot controller
- Teach pendant
- Connecting cables
- External axes (optional)
e.g. linear unit, turn-tilt table, positioner
- Software
- Options, accessories

The industrial robot is built using state-of-the-art technology and in accordance with the recognized safety rules. Nevertheless, misuse of the industrial robot may constitute a risk to life and limb or cause damage to the industrial robot and to other material property.

The industrial robot may only be used in perfect technical condition in accordance with its intended use and only by safety-conscious persons who are fully aware of the risks involved in its operation. Use of the industrial robot is subject to compliance with this document and with the declaration of incorporation supplied together with the industrial robot. Any functional disorders affecting the safety of the industrial robot must be rectified immediately.

Safety information

Safety information cannot be held against KUKA Roboter GmbH. Even if all safety instructions are followed, this is not a guarantee that the industrial robot will not cause personal injuries or material damage.

No modifications may be carried out to the industrial robot without the authorization of KUKA Roboter GmbH. Additional components (tools, software, etc.), not supplied by KUKA Roboter GmbH, may be integrated into the industrial robot. The user is liable for any damage these components may cause to the industrial robot or to other material property.

In addition to the Safety chapter, this document contains further safety instructions. These must also be observed.

3.1.2 Intended use of the industrial robot

The industrial robot is intended exclusively for the use designated in the "Purpose" chapter of the operating instructions or assembly instructions.



Further information is contained in the "Purpose" chapter of the operating instructions or assembly instructions of the industrial robot.

Using the industrial robot for any other or additional purpose is considered impermissible misuse. The manufacturer cannot be held liable for any damage resulting from such use. The risk lies entirely with the user.

Operating the industrial robot and its options within the limits of its intended use also involves observance of the operating and assembly instructions for

the individual components, with particular reference to the maintenance specifications.

Misuse

Any use or application deviating from the intended use is deemed to be impermissible misuse. This includes e.g.:

- Transportation of persons and animals
- Use as a climbing aid
- Operation outside the permissible operating parameters
- Use in potentially explosive environments
- Operation without additional safeguards
- Outdoor operation

3.1.3 EC declaration of conformity and declaration of incorporation

This industrial robot constitutes partly completed machinery as defined by the EC Machinery Directive. The industrial robot may only be put into operation if the following preconditions are met:

- The industrial robot is integrated into a complete system.
Or: The industrial robot, together with other machinery, constitutes a complete system.
Or: All safety functions and safeguards required for operation in the complete machine as defined by the EC Machinery Directive have been added to the industrial robot.
- The complete system complies with the EC Machinery Directive. This has been confirmed by means of an assessment of conformity.

Declaration of conformity

The system integrator must issue a declaration of conformity for the complete system in accordance with the Machinery Directive. The declaration of conformity forms the basis for the CE mark for the system. The industrial robot must be operated in accordance with the applicable national laws, regulations and standards.

The robot controller is CE certified under the EMC Directive and the Low Voltage Directive.

Declaration of incorporation

The industrial robot as partly completed machinery is supplied with a declaration of incorporation in accordance with Annex II B of the EC Machinery Directive 2006/42/EC. The assembly instructions and a list of essential requirements complied with in accordance with Annex I are integral parts of this declaration of incorporation.

The declaration of incorporation declares that the start-up of the partly completed machinery remains impermissible until the partly completed machinery has been incorporated into machinery, or has been assembled with other parts to form machinery, and this machinery complies with the terms of the EC Machinery Directive, and the EC declaration of conformity is present in accordance with Annex II A.

The declaration of incorporation, together with its annexes, remains with the system integrator as an integral part of the technical documentation of the complete machinery.

3.1.4 Terms used

Term	Description
Axis range	Range of each axis, in degrees or millimeters, within which it may move. The axis range must be defined for each axis.
Stopping distance	Stopping distance = reaction distance + braking distance The stopping distance is part of the danger zone.
Workspace	The manipulator is allowed to move within its workspace. The workspace is derived from the individual axis ranges.
Operator (User)	The user of the industrial robot can be the management, employer or delegated person responsible for use of the industrial robot.
Danger zone	The danger zone consists of the workspace and the stopping distances.
KCP	The KCP (KUKA Control Panel) teach pendant has all the operator control and display functions required for operating and programming the industrial robot.
Manipulator	The robot arm and the associated electrical installations
Safety zone	The safety zone is situated outside the danger zone.
Stop category 0	The drives are deactivated immediately and the brakes are applied. The manipulator and any external axes (optional) perform path-oriented braking. Note: This stop category is called STOP 0 in this document.
Stop category 1	The manipulator and any external axes (optional) perform path-maintaining braking. The drives are deactivated after 1 s and the brakes are applied. Note: This stop category is called STOP 1 in this document.
Stop category 2	The drives are not deactivated and the brakes are not applied. The manipulator and any external axes (optional) are braked with a normal braking ramp. Note: This stop category is called STOP 2 in this document.
System integrator (plant integrator)	System integrators are people who safely integrate the industrial robot into a complete system and commission it.
T1	Test mode, Manual Reduced Velocity (≤ 250 mm/s)
T2	Test mode, Manual High Velocity (> 250 mm/s permissible)
External axis	Motion axis which is not part of the manipulator but which is controlled using the robot controller, e.g. KUKA linear unit, turn-tilt table, Posiflex.

3.2 Personnel

The following persons or groups of persons are defined for the industrial robot:

- User
- Personnel



All persons working with the industrial robot must have read and understood the industrial robot documentation, including the safety chapter.

User

The user must observe the labor laws and regulations. This includes e.g.:

- The user must comply with his monitoring obligations.
- The user must carry out instructions at defined intervals.

Personnel

Personnel must be instructed, before any work is commenced, in the type of work involved and what exactly it entails as well as any hazards which may ex-

ist. Instruction must be carried out regularly. Instruction is also required after particular incidents or technical modifications.

Personnel includes:

- System integrator
- Operators, subdivided into:
 - Start-up, maintenance and service personnel
 - Operating personnel
 - Cleaning personnel



Installation, exchange, adjustment, operation, maintenance and repair must be performed only as specified in the operating or assembly instructions for the relevant component of the industrial robot and only by personnel specially trained for this purpose.

System integrator

The industrial robot is safely integrated into a complete system by the system integrator.

The system integrator is responsible for the following tasks:

- Installing the industrial robot
- Connecting the industrial robot
- Performing risk assessment
- Implementing the required safety functions and safeguards
- Issuing the declaration of conformity
- Attaching the CE mark
- Creating the operating instructions for the complete system

Operator

The operator must meet the following preconditions:

- The operator must be trained for the work to be carried out.
- Work on the industrial robot must only be carried out by qualified personnel. These are people who, due to their specialist training, knowledge and experience, and their familiarization with the relevant standards, are able to assess the work to be carried out and detect any potential hazards.

Example

The tasks can be distributed as shown in the following table.

Tasks	Operator	Programmer	System integrator
Switch robot controller on/off	x	x	x
Start program	x	x	x
Select program	x	x	x
Select operating mode	x	x	x
Calibration (tool, base)		x	x
Master the manipulator		x	x
Configuration		x	x
Programming		x	x
Start-up			x
Maintenance			x

Tasks	Operator	Programmer	System integrator
Repair			x
Decommissioning			x
Transportation			x



Work on the electrical and mechanical equipment of the industrial robot may only be carried out by specially trained personnel.

3.3 Workspace, safety zone and danger zone

Workspaces are to be restricted to the necessary minimum size. A workspace must be safeguarded using appropriate safeguards.

The safeguards (e.g. safety gate) must be situated inside the safety zone. In the case of a stop, the manipulator and external axes (optional) are braked and come to a stop within the danger zone.

The danger zone consists of the workspace and the stopping distances of the manipulator and external axes (optional). It must be safeguarded by means of physical safeguards to prevent danger to persons or the risk of material damage.

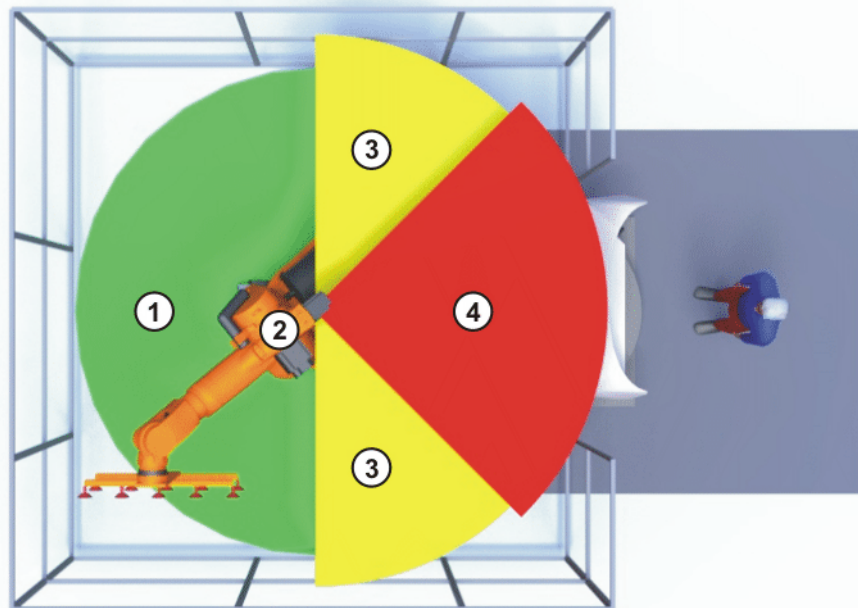

Fig. 3-1: Example of axis range A1

- | | | | |
|---|-------------|---|-------------------|
| 1 | Workspace | 3 | Stopping distance |
| 2 | Manipulator | 4 | Safety zone |

3.4 Triggers for stop reactions

Triggers for stop reactions

Stop reactions of the industrial robot are triggered in response to operator actions or as a reaction to monitoring functions and error messages. The following table shows the different stop reactions according to the operating mode that has been set.

STOP 0, STOP 1 and STOP 2 are the stop definitions according to DIN EN 60204-1:2006.

Trigger	T1, T2	AUT, AUT EXT
Safety gate opened	-	STOP 1
EMERGENCY STOP pressed	STOP 0	STOP 1
Enabling withdrawn	STOP 0	-
Start key released	STOP 2	-
"Drives OFF" key pressed	STOP 0	
STOP key pressed	STOP 2	
Operating mode changed	STOP 0	
Encoder error (DSE-RDC connection broken)	STOP 0	
Motion enable canceled	STOP 2	
Robot controller switched off	STOP 0	
Power failure		

3.5 Safety functions

3.5.1 Overview of safety functions

Safety functions:

- Mode selection
- Operator safety (= connection for the guard interlock)
- Local EMERGENCY STOP device (= EMERGENCY STOP button on the KCP)
- External EMERGENCY STOP device
- Enabling device

These circuits conform to the requirements of category 3 according to EN 954-1.

 **DANGER** In the absence of operational safety functions and safeguards, the industrial robot can cause personal injury or material damage. If safety functions or safeguards are dismantled or deactivated, the industrial robot may not be operated.

3.5.2 ESC safety logic

The function and triggering of the electronic safety functions are monitored by the ESC safety logic.

The ESC (Electronic Safety Circuit) safety logic is a dual-channel computer-aided safety system. It permanently monitors all connected safety-relevant components. In the event of a fault or interruption in the safety circuit, the power supply to the drives is shut off, thus bringing the industrial robot to a standstill.

The ESC safety logic triggers different stop reactions, depending on the operating mode of the industrial robot.

The ESC safety logic monitors the following inputs:

- Operator safety
- Local EMERGENCY STOP (= EMERGENCY STOP button on the KCP)

- External EMERGENCY STOP
- Enabling device
- Operating modes
- Qualifying inputs

3.5.3 Mode selector switch

The industrial robot can be operated in the following modes:

- Manual Reduced Velocity (T1)
- Manual High Velocity (T2)
- Automatic (AUT)
- Automatic External (AUT EXT)

The operating mode is selected using the mode selector switch on the KCP. The switch is activated by means of a key which can be removed. If the key is removed, the switch is locked and the operating mode can no longer be changed.

If the operating mode is changed during operation, the drives are immediately switched off. The manipulator and any external axes (optional) are stopped with a STOP 0.

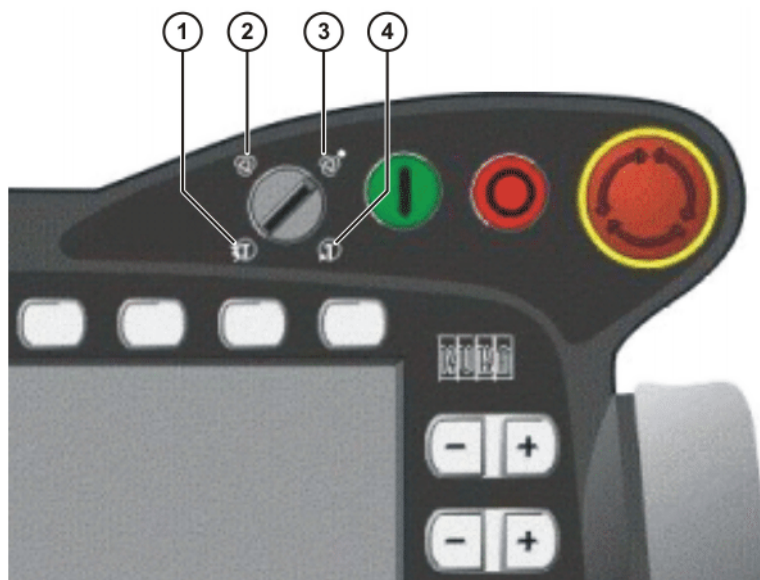

Fig. 3-2: Mode selector switch

- | | |
|---|------------------------------|
| 1 | T2 (Manual High Velocity) |
| 2 | AUT (Automatic) |
| 3 | AUT EXT (Automatic External) |
| 4 | T1 (Manual Reduced Velocity) |

Operating mode	Use	Velocities
T1	For test operation, programming and teaching	<ul style="list-style-type: none"> ■ Program verification: Programmed velocity, maximum 250 mm/s ■ Jog mode: Jog velocity, maximum 250 mm/s
T2	For test operation	<ul style="list-style-type: none"> ■ Program verification: Programmed velocity
AUT	For industrial robots without higher-level controllers Only possible with a connected safety circuit	<ul style="list-style-type: none"> ■ Program mode: Programmed velocity ■ Jog mode: Not possible
AUT EXT	For industrial robots with higher-level controllers, e.g. PLC Only possible with a connected safety circuit	<ul style="list-style-type: none"> ■ Program mode: Programmed velocity ■ Jog mode: Not possible

3.5.4 Operator safety

The operator safety input is used for interlocking physical safeguards. Safety equipment, such as safety gates, can be connected to the dual-channel input. If nothing is connected to this input, operation in Automatic mode is not possible. Operator safety is not active in the test modes T1 (Manual Reduced Velocity) and T2 (Manual High Velocity).

In the event of a loss of signal during Automatic operation (e.g. safety gate is opened), the manipulator and the external axes (optional) stop with a STOP 1. Once the signal is active at the input again, automatic operation can be resumed.

Operator safety can be connected via the peripheral interface on the robot controller.

 **WARNING** It must be ensured that the operator safety signal is not automatically reset when the safeguard (e.g. safety gate) is closed, but only after an additional manual acknowledgement signal has been given. Only in this way can it be ensured that automatic operation is not resumed inadvertently while there are still persons in the danger zone, e.g. due to the safety gate closing accidentally. Failure to observe this precaution may result in death, severe physical injuries or considerable damage to property.

3.5.5 EMERGENCY STOP device

The EMERGENCY STOP device for the industrial robot is the EMERGENCY STOP button on the KCP. The button must be pressed in the event of a hazardous situation or emergency.

Reactions of the industrial robot if the EMERGENCY STOP button is pressed:

- Manual Reduced Velocity (T1) and Manual High Velocity (T2) modes:
The drives are switched off immediately. The manipulator and any external axes (optional) are stopped with a STOP 0.
- Automatic modes (AUT and AUT EXT):
The drives are switched off after 1 second. The manipulator and any external axes (optional) are stopped with a STOP 1.

Before operation can be resumed, the EMERGENCY STOP button must be turned to release it and the stop message must be acknowledged.



Fig. 3-3: EMERGENCY STOP button on the KCP

1 EMERGENCY STOP button

WARNING Tools and other equipment connected to the manipulator must be integrated into the EMERGENCY STOP circuit on the system side if they could constitute a potential hazard. Failure to observe this precaution may result in death, severe physical injuries or considerable damage to property.

3.5.6 External EMERGENCY STOP device

There must be EMERGENCY STOP devices available at every operator station that can initiate a robot motion or other potentially hazardous situation. The system integrator is responsible for ensuring this.

There must always be at least one external EMERGENCY STOP device installed. This ensures that an EMERGENCY STOP device is available even when the KCP is disconnected.

External EMERGENCY STOP devices are connected via the customer interface. External EMERGENCY STOP devices are not included in the scope of supply of the industrial robot.

3.5.7 Enabling device

The enabling devices of the industrial robot are the enabling switches on the KCP.

There are 3 enabling switches installed on the KCP. The enabling switches have 3 positions:

- Not pressed
- Center position
- Panic position

In the test modes, the manipulator can only be moved if one of the enabling switches is held in the central position. If the enabling switch is released or pressed fully down (panic position), the drives are deactivated immediately and the manipulator stops with a STOP 0.

**WARNING**

The enabling switches must not be held down by adhesive tape or other means or manipulated in any other way.

Death, serious physical injuries or major damage to property may result.



Fig. 3-4: Enabling switches on the KCP

1 - 3 Enabling switches

3.6 Additional protective equipment

3.6.1 Jog mode

In the operating modes T1 (Manual Reduced Velocity) and T2 (Manual High Velocity), the robot controller can only execute programs in jog mode. This means that it is necessary to hold down an enabling switch and the Start key in order to execute a program.

If the enabling switch is released or pressed fully down (panic position), the drives are deactivated immediately and the manipulator and any external axes (optional) stop with a STOP 0.

Releasing only the Start key causes the industrial robot to be stopped with a STOP 2.

3.6.2 Software limit switches

The axis ranges of all manipulator and positioner axes are limited by means of adjustable software limit switches. These software limit switches only serve as machine protection and must be adjusted in such a way that the manipulator/positioner cannot hit the mechanical end stops.

The software limit switches are set during commissioning of an industrial robot.

 Further information is contained in the operating and programming instructions.

3.6.3 Labeling on the industrial robot

All plates, labels, symbols and marks constitute safety-relevant parts of the industrial robot. They must not be modified or removed.

Labeling on the industrial robot consists of:

- Identification plates
- Warning labels
- Safety symbols
- Designation labels
- Cable markings
- Rating plates

 Further information is contained in the technical data of the operating instructions or assembly instructions of the components of the industrial robot.

3.6.4 External safeguards

Safeguards

The access of persons to the danger zone of the manipulator must be prevented by means of safeguards.

Physical safeguards must meet the following requirements:

- They meet the requirements of EN 953.
- They prevent access of persons to the danger zone and cannot be easily circumvented.
- They are sufficiently fastened and can withstand all forces that are likely to occur in the course of operation, whether from inside or outside the enclosure.
- They do not, themselves, represent a hazard or potential hazard.
- The prescribed minimum clearance from the danger zone is maintained.

Safety gates (maintenance gates) must meet the following requirements:

- They are reduced to an absolute minimum.
- The interlocks (e.g. safety gate switches) are linked to the operator safety input of the robot controller via safety gate switching devices or safety PLC.
- Switching devices, switches and the type of switching conform to the requirements of category 3 according to EN 954-1.
- Depending on the risk situation: the safety gate is additionally safeguarded by means of a locking mechanism that only allows the gate to be opened if the manipulator is safely at a standstill.

- The button for acknowledging the safety gate is located outside the space limited by the safeguards.



Further information is contained in the corresponding standards and regulations. These also include EN 953.

Other safety equipment

Other safety equipment must be integrated into the system in accordance with the corresponding standards and regulations.

3.7 Overview of operating modes and safety functions

The following table indicates the operating modes in which the safety functions are active.

Safety functions	T1	T2	AUT	AUT EXT
Operator safety	-	-	active	active
EMERGENCY STOP device	active	active	active	active
Enabling device	active	active	-	-
Reduced velocity during program verification	active	-	-	-
Jog mode	active	active	-	-
Software limit switches	active	active	active	active

3.8 Safety measures

3.8.1 General safety measures

The industrial robot may only be used in perfect technical condition in accordance with its intended use and only by safety-conscious persons. Operator errors can result in personal injury and damage to property.

It is important to be prepared for possible movements of the industrial robot even after the robot controller has been switched off and locked. Incorrect installation (e.g. overload) or mechanical defects (e.g. brake defect) can cause the manipulator or external axes to sag. If work is to be carried out on a switched-off industrial robot, the manipulator and external axes must first be moved into a position in which they are unable to move on their own, whether the payload is mounted or not. If this is not possible, the manipulator and external axes must be secured by appropriate means.



DANGER In the absence of operational safety functions and safeguards, the industrial robot can cause personal injury or material damage. If safety functions or safeguards are dismantled or deactivated, the industrial robot may not be operated.



WARNING Standing underneath the robot arm can cause death or serious physical injuries. For this reason, standing underneath the robot arm is prohibited!

CAUTION The motors reach temperatures during operation which can cause burns to the skin. Contact must be avoided. Appropriate safety precautions must be taken, e.g. protective gloves must be worn.

KCP

The user must ensure that the industrial robot is only operated with the KCP by authorized persons.

If more than one KCP is used in the overall system, it must be ensured that each KCP is unambiguously assigned to the corresponding industrial robot. They must not be interchanged.

WARNING The operator must ensure that decoupled KCPs are immediately removed from the system and stored out of sight and reach of personnel working on the industrial robot. This serves to prevent operational and non-operational EMERGENCY STOP facilities from becoming interchanged. Failure to observe this precaution may result in death, severe physical injuries or considerable damage to property.

External keyboard, external mouse

An external keyboard and/or external mouse may only be used if the following conditions are met:

- Start-up or maintenance work is being carried out.
- The drives are switched off.
- There are no persons in the danger zone.

The KCP must not be used as long as an external keyboard and/or external mouse are connected.

The external keyboard and/or external mouse must be removed as soon as the start-up or maintenance work is completed or the KCP is connected.

Faults

The following tasks must be carried out in the case of faults in the industrial robot:

- Switch off the robot controller and secure it (e.g. with a padlock) to prevent unauthorized persons from switching it on again.
- Indicate the fault by means of a label with a corresponding warning (tag-out).
- Keep a record of the faults.
- Eliminate the fault and carry out a function test.

Modifications

After modifications to the industrial robot, checks must be carried out to ensure the required safety level. The valid national or regional work safety regulations must be observed for this check. The correct functioning of all safety circuits must also be tested.

New or modified programs must always be tested first in Manual Reduced Velocity mode (T1).

After modifications to the industrial robot, existing programs must always be tested first in Manual Reduced Velocity mode (T1). This applies to all components of the industrial robot and includes modifications to the software and configuration settings.

3.8.2 Transportation**Manipulator**

The prescribed transport position of the manipulator must be observed. Transportation must be carried out in accordance with the operating instructions or assembly instructions of the manipulator.

Robot controller	<p>The robot controller must be transported and installed in an upright position. Avoid vibrations and impacts during transportation in order to prevent damage to the robot controller.</p> <p>Transportation must be carried out in accordance with the operating instructions or assembly instructions of the robot controller.</p>
External axis (optional)	<p>The prescribed transport position of the external axis (e.g. KUKA linear unit, turn-tilt table, etc.) must be observed. Transportation must be carried out in accordance with the operating instructions or assembly instructions of the external axis.</p>

3.8.3 Start-up and recommissioning

Before starting up systems and devices for the first time, a check must be carried out to ensure that the systems and devices are complete and operational, that they can be operated safely and that any damage is detected.

The valid national or regional work safety regulations must be observed for this check. The correct functioning of all safety circuits must also be tested.



The passwords for logging onto the KUKA System Software as “Expert” and “Administrator” must be changed before start-up and must only be communicated to authorized personnel.



DANGER The robot controller is preconfigured for the specific industrial robot. If cables are interchanged, the manipulator and the external axes (optional) may receive incorrect data and can thus cause personal injury or material damage. If a system consists of more than one manipulator, always connect the connecting cables to the manipulators and their corresponding robot controllers.



If additional components (e.g. cables), which are not part of the scope of supply of KUKA Roboter GmbH, are integrated into the industrial robot, the user is responsible for ensuring that these components do not adversely affect or disable safety functions.

NOTICE

If the internal cabinet temperature of the robot controller differs greatly from the ambient temperature, condensation can form, which may cause damage to the electrical components. Do not put the robot controller into operation until the internal temperature of the cabinet has adjusted to the ambient temperature.

Function test

The following tests must be carried out before start-up and recommissioning:

General test:

It must be ensured that:

- The industrial robot is correctly installed and fastened in accordance with the specifications in the documentation.
- There are no foreign bodies or loose parts on the industrial robot.
- All required safety equipment is correctly installed and operational.
- The power supply ratings of the industrial robot correspond to the local supply voltage and mains type.
- The ground conductor and the equipotential bonding cable are sufficiently rated and correctly connected.
- The connecting cables are correctly connected and the connectors are locked.

Test of safety-oriented circuits:

A function test must be carried out for the following safety-oriented circuits to ensure that they are functioning correctly:

- Local EMERGENCY STOP device (= EMERGENCY STOP button on the KCP)
- External EMERGENCY STOP device (input and output)
- Enabling device (in the test modes)
- Operator safety (in the automatic modes)
- Qualifying inputs (if connected)
- All other safety-relevant inputs and outputs used

Test of reduced velocity control:

This test is to be carried out as follows:

1. Program a straight path with the maximum possible velocity.
2. Calculate the length of the path.
3. Execute the path in T1 mode with the override set to 100% and time the motion with a stopwatch.

 **WARNING** It must be ensured that no persons are present within the danger zone during path execution. Death or severe physical injuries may result.

4. Calculate the velocity from the length of the path and the time measured for execution of the motion.

Control of reduced velocity is functioning correctly if the following results are achieved:

- The calculated velocity does not exceed 250 mm/s.
- The robot executes the path as programmed (i.e. in a straight line, without deviations).

Machine data

It must be ensured that the rating plate on the robot controller has the same machine data as those entered in the declaration of incorporation. The machine data on the rating plate of the manipulator and the external axes (optional) must be entered during start-up.

 **DANGER** The industrial robot must not be moved if incorrect machine data are loaded. Death, severe physical injuries or considerable damage to property may otherwise result. The correct machine data must be loaded.

3.8.4 Virus protection and network security

The user of the industrial robot is responsible for ensuring that the software is always safeguarded with the latest virus protection. If the robot controller is integrated into a network that is connected to the company network or to the Internet, it is advisable to protect this robot network against external risks by means of a firewall.

 For optimal use of our products, we recommend that our customers carry out a regular virus scan. Information about security updates can be found at www.kuka.com.

3.8.5 Manual mode

Manual mode is the mode for setup work. Setup work is all the tasks that have to be carried out on the industrial robot to enable automatic operation. Setup work includes:

- Jog mode
- Teaching
- Programming
- Program verification

The following must be taken into consideration in manual mode:

- If the drives are not required, they must be switched off to prevent the manipulator or the external axes (optional) from being moved unintentionally. New or modified programs must always be tested first in Manual Reduced Velocity mode (T1).
- The manipulator, tooling or external axes (optional) must never touch or project beyond the safety fence.
- Components, tooling and other objects must not become jammed as a result of the industrial robot motion, nor must they lead to short-circuits or be liable to fall off.
- All setup work must be carried out, where possible, from outside the safeguarded area.

If the setup work has to be carried out inside the safeguarded area, the following must be taken into consideration:

In **Manual Reduced Velocity mode (T1)**:

- If it can be avoided, there must be no other persons inside the safeguarded area.
If it is necessary for there to be several persons inside the safeguarded area, the following must be observed:
 - Each person must have an enabling device.
 - All persons must have an unimpeded view of the industrial robot.
 - Eye-contact between all persons must be possible at all times.
- The operator must be so positioned that he can see into the danger area and get out of harm's way.

In **Manual High Velocity mode (T2)**:

- This mode may only be used if the application requires a test at a velocity higher than Manual Reduced Velocity.
- Teaching and programming are not permissible in this operating mode.
- Before commencing the test, the operator must ensure that the enabling devices are operational.
- The operator must be positioned outside the danger zone.
- There must be no other persons inside the safeguarded area. It is the responsibility of the operator to ensure this.

3.8.6 Simulation

Simulation programs do not correspond exactly to reality. Robot programs created in simulation programs must be tested in the system in **Manual Reduced Velocity mode (T1)**. It may be necessary to modify the program.

3.8.7 Automatic mode

Automatic mode is only permissible in compliance with the following safety measures:

- All safety equipment and safeguards are present and operational.
- There are no persons in the system.
- The defined working procedures are adhered to.

If the manipulator or an external axis (optional) comes to a standstill for no apparent reason, the danger zone must not be entered until an EMERGENCY STOP has been triggered.

3.8.8 Maintenance and repair

After maintenance and repair work, checks must be carried out to ensure the required safety level. The valid national or regional work safety regulations must be observed for this check. The correct functioning of all safety circuits must also be tested.

The purpose of maintenance and repair work is to ensure that the system is kept operational or, in the event of a fault, to return the system to an operational state. Repair work includes troubleshooting in addition to the actual repair itself.

The following safety measures must be carried out when working on the industrial robot:

- Carry out work outside the danger zone. If work inside the danger zone is necessary, the user must define additional safety measures to ensure the safe protection of personnel.
- Switch off the industrial robot and secure it (e.g. with a padlock) to prevent it from being switched on again. If it is necessary to carry out work with the robot controller switched on, the user must define additional safety measures to ensure the safe protection of personnel.
- If it is necessary to carry out work with the robot controller switched on, this may only be done in operating mode T1.
- Label the system with a sign indicating that work is in progress. This sign must remain in place, even during temporary interruptions to the work.
- The EMERGENCY STOP systems must remain active. If safety functions or safeguards are deactivated during maintenance or repair work, they must be reactivated immediately after the work is completed.

Faulty components must be replaced using new components with the same article numbers or equivalent components approved by KUKA Roboter GmbH for this purpose.

Cleaning and preventive maintenance work is to be carried out in accordance with the operating instructions.

Robot controller

Even when the robot controller is switched off, parts connected to peripheral devices may still carry voltage. The external power sources must therefore be switched off if work is to be carried out on the robot controller.

The ESD regulations must be adhered to when working on components in the robot controller.

Voltages in excess of 50 V (up to 600 V) can be present in various components for several minutes after the robot controller has been switched off! To prevent life-threatening injuries, no work may be carried out on the industrial robot in this time.

Water and dust must be prevented from entering the robot controller.

Hazardous substances

The following safety measures must be carried out when handling hazardous substances:

- Avoid prolonged and repeated intensive contact with the skin.
- Avoid breathing in oil spray or vapors.
- Clean skin and apply skin cream.



To ensure safe use of our products, we recommend that our customers regularly request up-to-date safety data sheets from the manufacturers of hazardous substances.

3.8.9 Decommissioning, storage and disposal

The industrial robot must be decommissioned, stored and disposed of in accordance with the applicable national laws, regulations and standards.

3.8.10 Safety measures for “single point of control”**Overview**

If certain components in the industrial robot are operated, safety measures must be taken to ensure complete implementation of the principle of “single point of control”.

Components:

- Submit interpreter
- PLC
- OPC Server
- Remote control tools
- External keyboard/mouse



The implementation of additional safety measures may be required. This must be clarified for each specific application; this is the responsibility of the system integrator, programmer or user of the system.

Since only the system integrator knows the safe states of actuators in the periphery of the robot controller, it is his task to set these actuators to a safe state, e.g. in the event of an EMERGENCY STOP.

External keyboard/mouse

These components can be used to modify programs, outputs or other parameters of the robot controller, without this being noticed by any persons located inside the system.

Safety measures:

- Only use one operator console at each robot controller.
- If the KCP is being used for work inside the system, remove any keyboard and mouse from the robot controller beforehand.

OPC server, remote control tools

These components can be used with write access to modify programs, outputs or other parameters of the robot controller, without this being noticed by any persons located inside the system.

Safety measures:

- KUKA stipulates that these components are to be used exclusively for diagnosis and visualization.
Programs, outputs or other parameters of the robot controller must not be modified using these components.

Submit interpreter, PLC

If motions, (e.g. drives or grippers) are controlled with the Submit interpreter or the PLC via the I/O system, and if they are not safeguarded by other means,

then this control will take effect even in T1 and T2 modes or while an EMERGENCY STOP is active.

If variables that affect the robot motion (e.g. override) are modified with the Submit interpreter or the PLC, this takes effect even in T1 and T2 modes or while an EMERGENCY STOP is active.

Safety measures:

- Do not modify safety-relevant signals and variables (e.g. operating mode, EMERGENCY STOP, safety gate contact) via the Submit interpreter or PLC.
- If modifications are nonetheless required, all safety-relevant signals and variables must be linked in such a way that they cannot be set to a dangerous state by the Submit interpreter or PLC.

3.9 Applied norms and regulations

Name	Definition	Edition
2006/42/EC	Machinery Directive: Directive 2006/42/EC of the European Parliament and of the Council of 17 May 2006 on machinery, and amending Directive 95/16/EC (recast)	2006
2004/108/EC	EMC Directive: Directive 2004/108/EC of the European Parliament and of the Council of 15 December 2004 on the approximation of the laws of the Member States relating to electromagnetic compatibility and repealing Directive 89/336/EEC	2004
EN ISO 13850	Safety of machinery: Emergency stop - Principles for design	2008
EN ISO 12100-1	Safety of machinery: Basic concepts, general principles for design - Part 1: Basic terminology, methodology	2003
EN ISO 12100-2	Safety of machinery: Basic concepts, general principles for design - Part 2: Technical principles	2003
EN ISO 10218-1	Industrial robots: Safety	2008
EN 954-1	Safety of machinery: Safety-related parts of control systems - Part 1: General principles of design	1997
EN 614-1	Safety of machinery: Ergonomic design principles - Part 1: Terms and general principles	2006
EN 61000-6-2	Electromagnetic compatibility (EMC): Part 6-2: Generic standards; Immunity for industrial environments	2005

Name	Definition	Edition
EN 61000-6-4	Electromagnetic compatibility (EMC): Part 6-4: Generic standards; Emission standard for industrial environments	2007
EN 60204-1	Safety of machinery: Electrical equipment of machines - Part 1: General requirements	2006

4 Planning

4.1 Mounting base

Description

The robot is fastened directly to the mounting base with 4 bolts. A suitable steel construction can be used as the mounting base. The mounting surface must be at least 20 mm thick. It must be ensured that the steel structure is able to withstand safely and permanently the dynamic loads (>>> 2.4 "Loads acting on the foundation" Page 14) to which it is subjected.

In order to fasten the robot to a concrete foundation, a suitable steel plate must be prepared and fastened to the concrete foundation.

The connecting cables to the robot controller must be installed in a cable duct. If required, additional measures must be taken to ensure electromagnetic compatibility (EMC).



Installation, connection and start-up of the robot must be carried out in accordance with the applicable national laws and regulations. The robot may only be started up if the applicable regulations have been observed.

Hole pattern

The following holes must be used for mounting the robot.

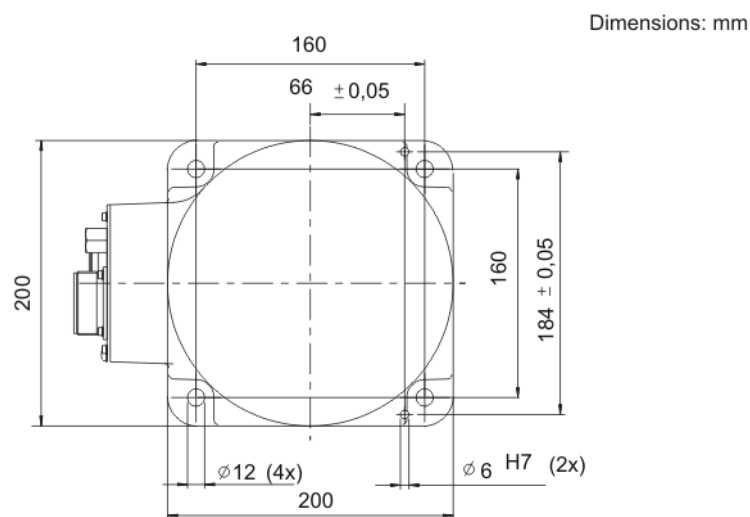

Fig. 4-1: Hole pattern

4.2 Instructions for mechanical axis range limitation

Description

The robot's working envelope can be reduced to the required minimum in axes 1 to 3 using mechanical axis range limitation systems.

NOTICE

If the mechanical axis range limits are changed, the robot could collide with its end stops, resulting in damage to the robot and its tooling. The software limit switches must be set to a position at least 2 to 3° in front of the axis range limits.

In order to be able to use the mechanical axis range limitations, it is necessary to construct it. Instructions are supplied.

Axis	Mechanical axis range limitation
1	<p>Plate with fastening blocks and 2 stops</p> <p>(>>> 4.2.1 "Instructions for mechanical axis range limitation on A1" Page 42)</p>
2	<p>Stop</p> <p>(>>> 4.2.2 "Instructions for mechanical axis range limitation on A2" Page 43)</p>
3	<p>Stop with holder</p> <p>(>>> 4.2.3 "KR 5 sixx R650: instructions for mechanical axis range limitation on A3" Page 44)</p> <p>(>>> 4.2.4 "KR 5 sixx R850: instructions for mechanical axis range limitation on A3" Page 45)</p>

4.2.1 Instructions for mechanical axis range limitation on A1

Description

Two stops are used to limit the axis range for axis 1.

Axis range limitation	Description
Plate	Material: S45C
2 fastening blocks A	Material: S45C M8x16-12.9 Allen screws Tightening torque $M_A = 36 \pm 7.2$ Nm
2 stops	Material: A2017 M8x16-12.9 Allen screws Tightening torque $M_A = 20 \pm 4$ Nm
Fastening block B	Material: S45C M8x16-12.9 Allen screws Tightening torque $M_A = 36 \pm 7.2$ Nm

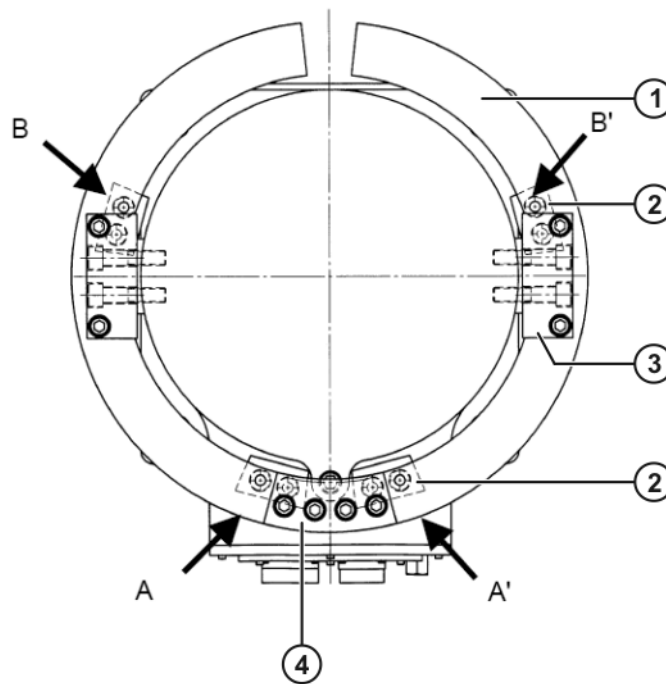

Fig. 4-2: Mechanical axis range limitation, axis 1

- | | | | |
|---|-------|---|-------------------|
| 1 | Plate | 3 | Fastening block A |
| 2 | Stop | 4 | Fastening block B |

Item	Axis limit +	Axis limit -
A	5°	28°45'
A'	-28°45'	-5°
B	95°	118°45'
B'	-118°45'	-95°

NOTICE Axis 1 must not be moved between positions A and A' to avoid damage to the energy supply system. Do not remove the screw at position 1.

For detailed specifications of the mechanical axis range limitation for axis 1, see (>>> 6.1 "Mechanical axis range limitation on axis 1, dimensioned drawings" Page 51).

4.2.2 Instructions for mechanical axis range limitation on A2

Description

A stop is used to limit the axis range for axis 2.

Axis range limitation	Description
Stop	Material: A2017-T4 M8x25 Allen screws Tightening torque $M_A = 19.6 \pm 3.9 \text{ Nm}$

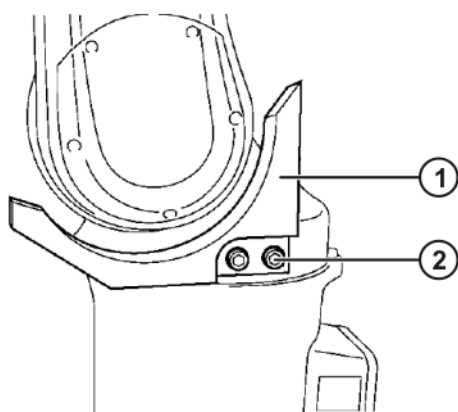

Fig. 4-3: Mechanical axis range limitation, axis 2

- 1 Mechanical axis range limitation, axis 2
- 2 Allen screw

For detailed specifications of the mechanical axis range limitation for axis 2, see (>>> 6.2 "Mechanical axis range limitation on axis 2, dimensioned drawings" Page 52).

4.2.3 KR 5 sixx R650: instructions for mechanical axis range limitation on A3

Description

A stop is used to limit the axis range for axis 3.

Axis range limitation	Description
Stop	Material: A2017-T4 M6x20 Allen screws Tightening torque $M_A = 9.8 \pm 2$ Nm
Holder for the stop	Material: A2017-T4 M5x35 Allen screws Tightening torque $M_A = 5.9 \pm 1.2$ Nm M8x35 Allen screw with nut, thread length: 32 mm Tightening torque $M_A = 10 \pm 2$ Nm
Spacer	Material: S45C

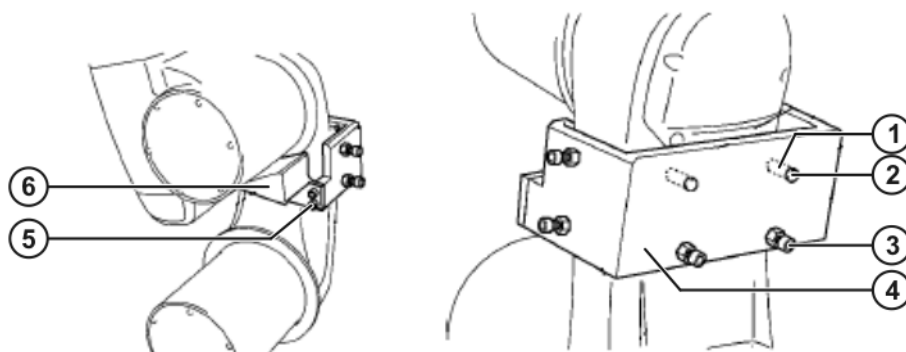

Fig. 4-4: Mechanical axis range limitation, axis 3

- 1 Spacer
- 2 Allen screw
- 3 Allen screw
- 4 Holder for the stop

- | | | | |
|---|----------------------------|---|-----------------|
| 2 | M5x35 screw | 5 | Allen screw |
| 3 | M8x35 Allen screw with nut | 6 | Mechanical stop |

For detailed specifications of the mechanical axis range limitation for axis 3, see (>>> 6.3 "KR 5 sixx R650: mechanical axis range limitation on axis 3, dimensioned drawings" Page 53).

4.2.4 KR 5 sixx R850: instructions for mechanical axis range limitation on A3

Description

A stop is used to limit the axis range for axis 3.

Axis range limitation	Description
Stop	Material: A5083P-H32 M6x20 Allen screws Tightening torque $M_A = 9.8 \pm 2$ Nm
Holder for the stop	Material: A2017-T4 M5x35 Allen screws Tightening torque $M_A = 5.9 \pm 1.2$ Nm M8x35 Allen screw with nut, thread length: 32 mm Tightening torque $M_A = 10 \pm 2$ Nm
Spacer	Material: S45C

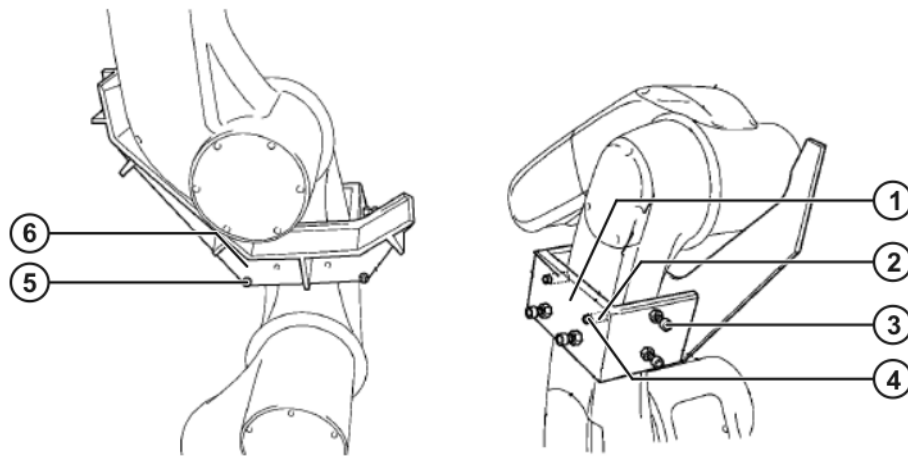

Fig. 4-5: Mechanical axis range limitation, axis 3

- | | | | |
|---|---------------------|---|-----------------|
| 1 | Holder for the stop | 4 | Allen screw |
| 2 | Screw | 5 | Mechanical stop |
| 3 | Spacer | 6 | Allen screw |

For detailed specifications of the mechanical axis range limitation for axis 3, see (>>> 6.4 "KR 5 sixx R850: mechanical axis range limitation on axis 3, dimensioned drawings" Page 55).

5 Transportation

5.1 Transporting the robot

It must be ensured that the robot is stable while it is being transported. The robot must remain in its transport position until it has been fastened in position. Before the robot is lifted it must be ensured that it is free from obstructions. Remove all transport safeguards, such as nails and screws, in advance. First remove any rust or glue on contact surfaces.



The robot is packaged in 2 protective wrappers. The 1st protective wrapper may only be removed in the airlock, and the 2nd protective wrapper only in the cleanroom itself.



Before the robot is transported into the cleanroom, it is essential to clean the base frame in order to prevent dirt particles from being carried into the cleanroom.

Transport position

The robot must be in the transport position (>>> Fig. 5-1) before it can be transported. The robot is in the transport position when the axes are in the following positions:

Type	A1 [°]	A2 [°]	A3 [°]	A4 [°]	A5 [°]	A6 [°]
KR 5 sixx CR	0	-145	+163	+90	+90	0

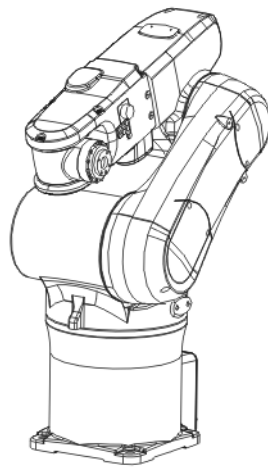

Fig. 5-1: Transport position

Transport dimensions

The dimensions for the robot transport can be noted from the following figure. The position of the center of mass and the weight vary according to the specific configuration. The specified dimensions refer to the robot without equipment.

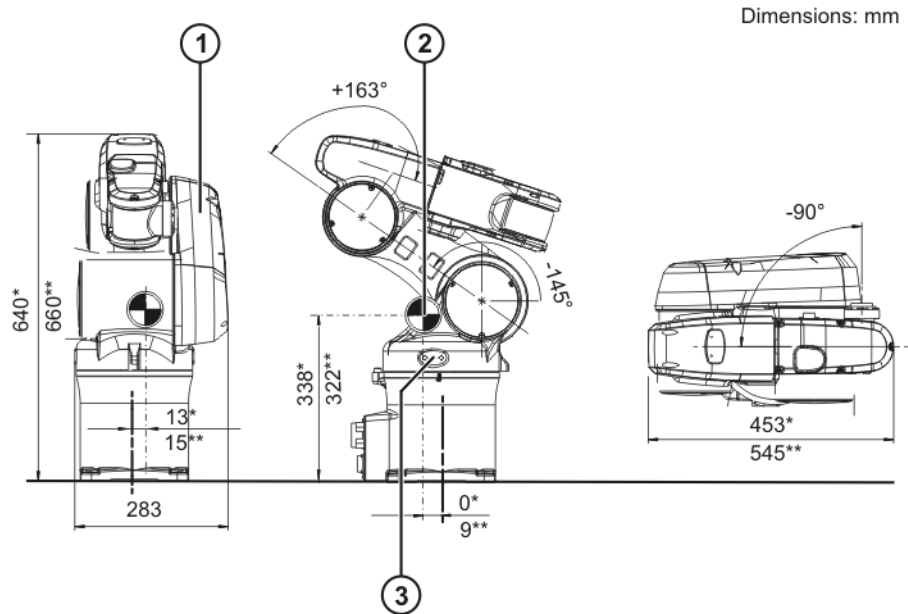

Fig. 5-2: Transport dimensions

- | | | | |
|---|-------------------|----|-------------------|
| 1 | Robot | * | KR 5 sixx R650 CR |
| 2 | Center of gravity | ** | KR 5 sixx R850 CR |
| 3 | Eyebolt | | |

Transportation

The robot can be transported by fork lift truck or using lifting tackle.

WARNING Use of unsuitable handling equipment may result in damage to the robot or injury to persons. Only use authorized handling equipment with a sufficient load-bearing capacity. Only transport the robot in the manner specified here.

Transportation by fork lift truck

For transport by fork lift truck, the robot must be screwed to a pallet using 4 bolts. A Euro pallet or the pallet used for delivery is suitable for this purpose.

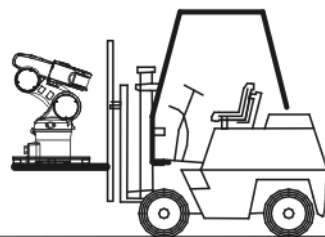

Fig. 5-3: Transport by fork lift truck

Transportation using lifting tackle

A floor-mounted robot can also be transported using lifting tackle. The robot must be in the transport position (>>> Fig. 5-1). The lifting tackle (>>> Fig. 5-4) is attached to 2 eyebolts screwed into the base frame.

WARNING The robot may tip during transportation. Risk of personal injury and damage to property. If the robot is being transported using lifting tackle, special care must be exercised to prevent it from tipping. Additional safeguarding measures must be taken. It is forbidden to pick up the robot in any other way using a crane!

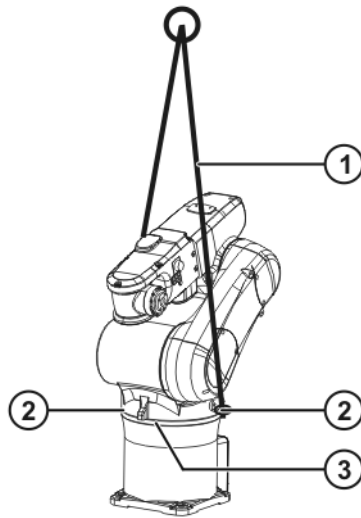

Fig. 5-4: Lifting tackle

- 1 Lifting tackle
- 2 Eyebolt
- 3 Rotating column

6 Appendix

6.1 Mechanical axis range limitation on axis 1, dimensioned drawings

Plate

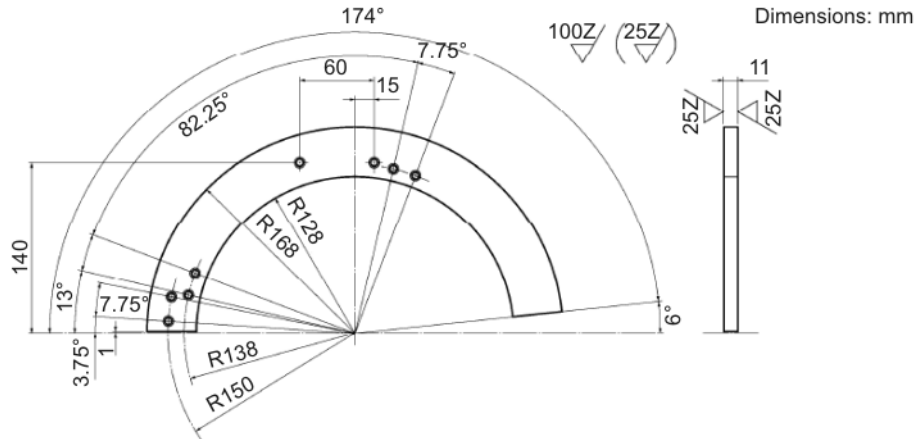

Fig. 6-1: Plate, dimensioned drawing

Fastening block A

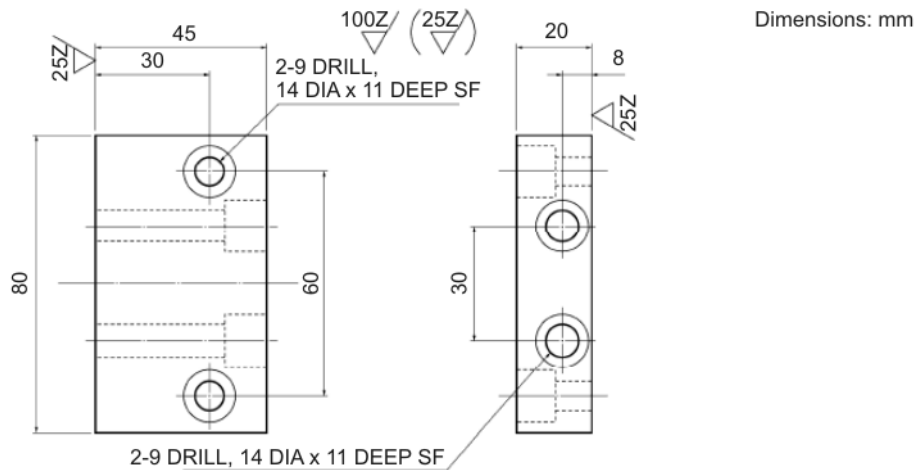

Fig. 6-2: Fastening block A, dimensioned drawing

Fastening block B

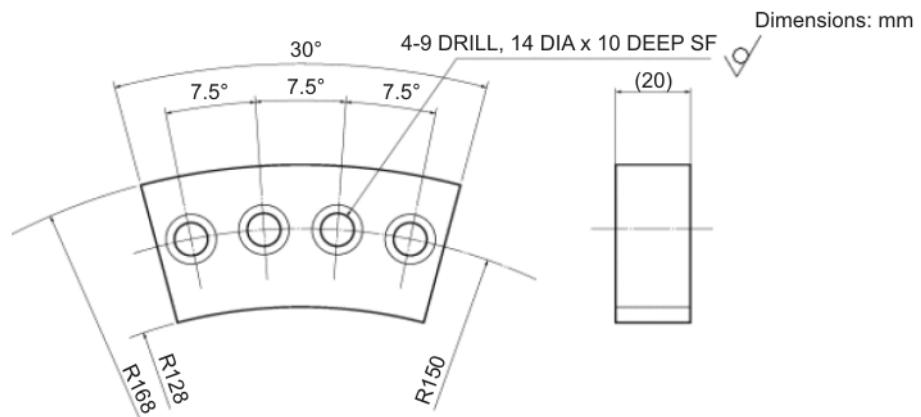
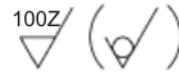

Fig. 6-3: Fastening block B, dimensioned drawing

Stop



Dimensions: mm

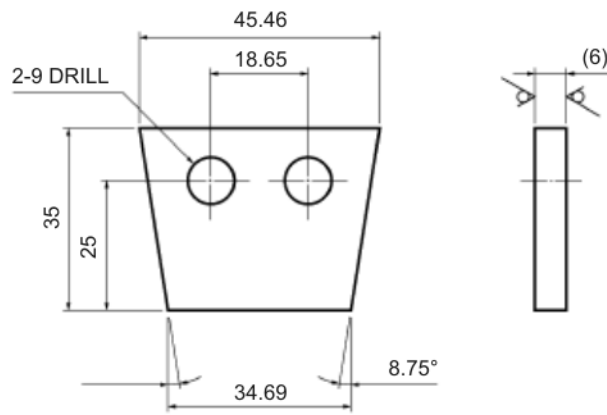

Fig. 6-4: Mechanical stop, dimensioned drawing

6.2 Mechanical axis range limitation on axis 2, dimensioned drawings

Stop

Dimensions: mm

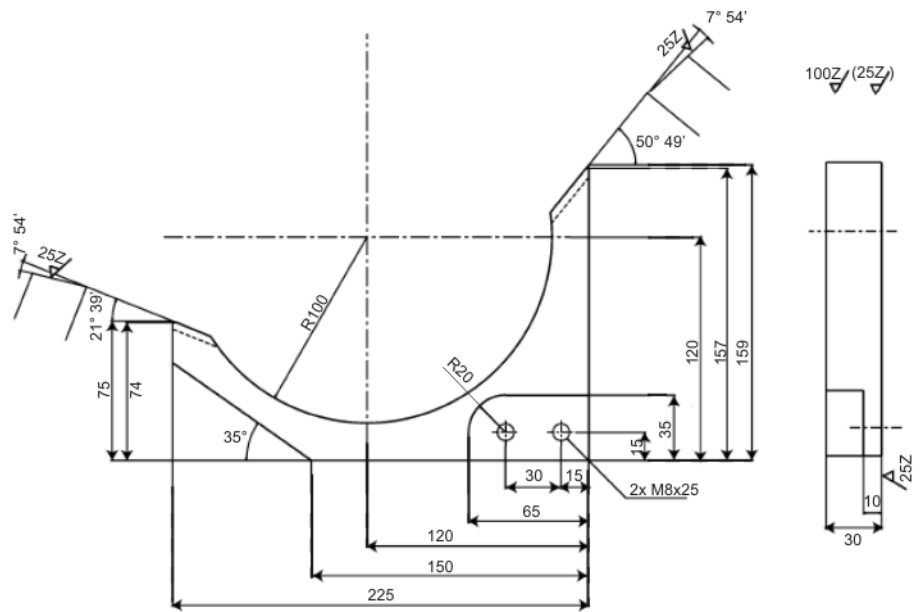

Fig. 6-5: Mechanical stop, dimensioned drawing

6.3 KR 5 sixx R650: mechanical axis range limitation on axis 3, dimensioned drawings

Stop

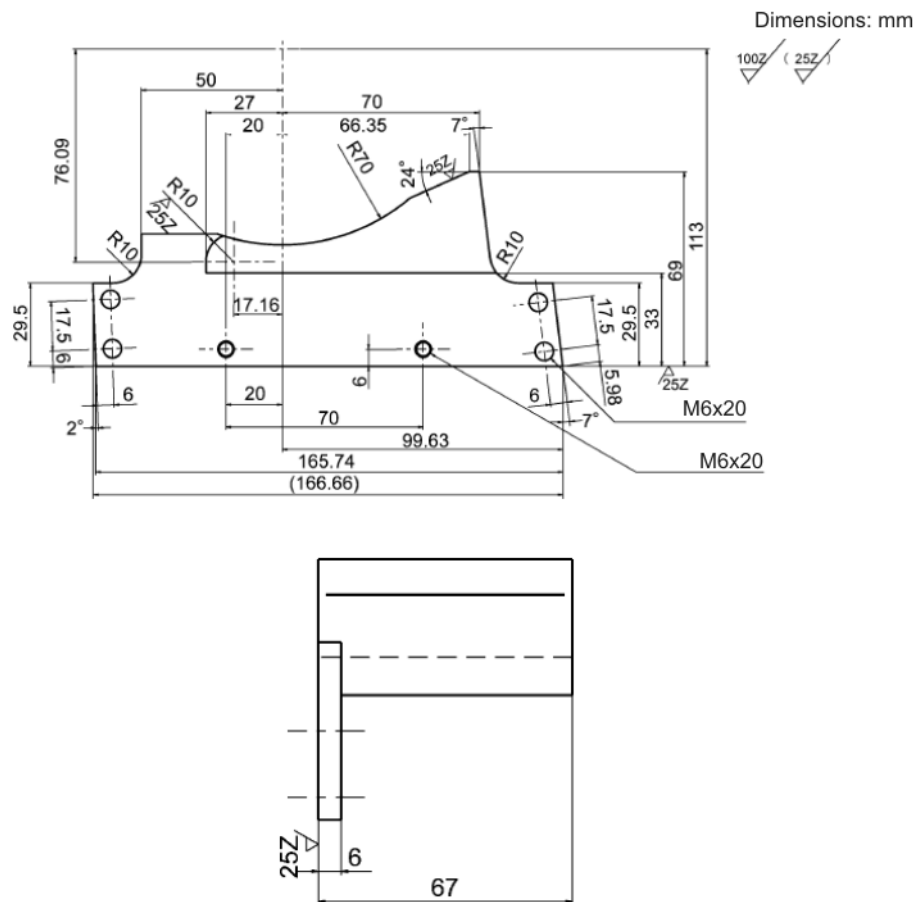

Fig. 6-6: Mechanical stop, dimensioned drawing

Spacer

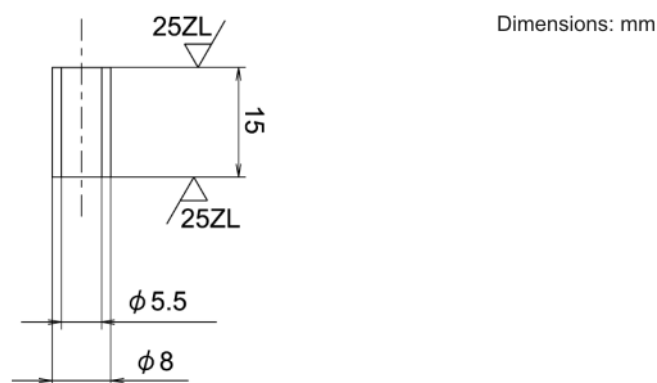

Fig. 6-7: Spacer, dimensioned drawing

Holder for stop

Dimensions: mm

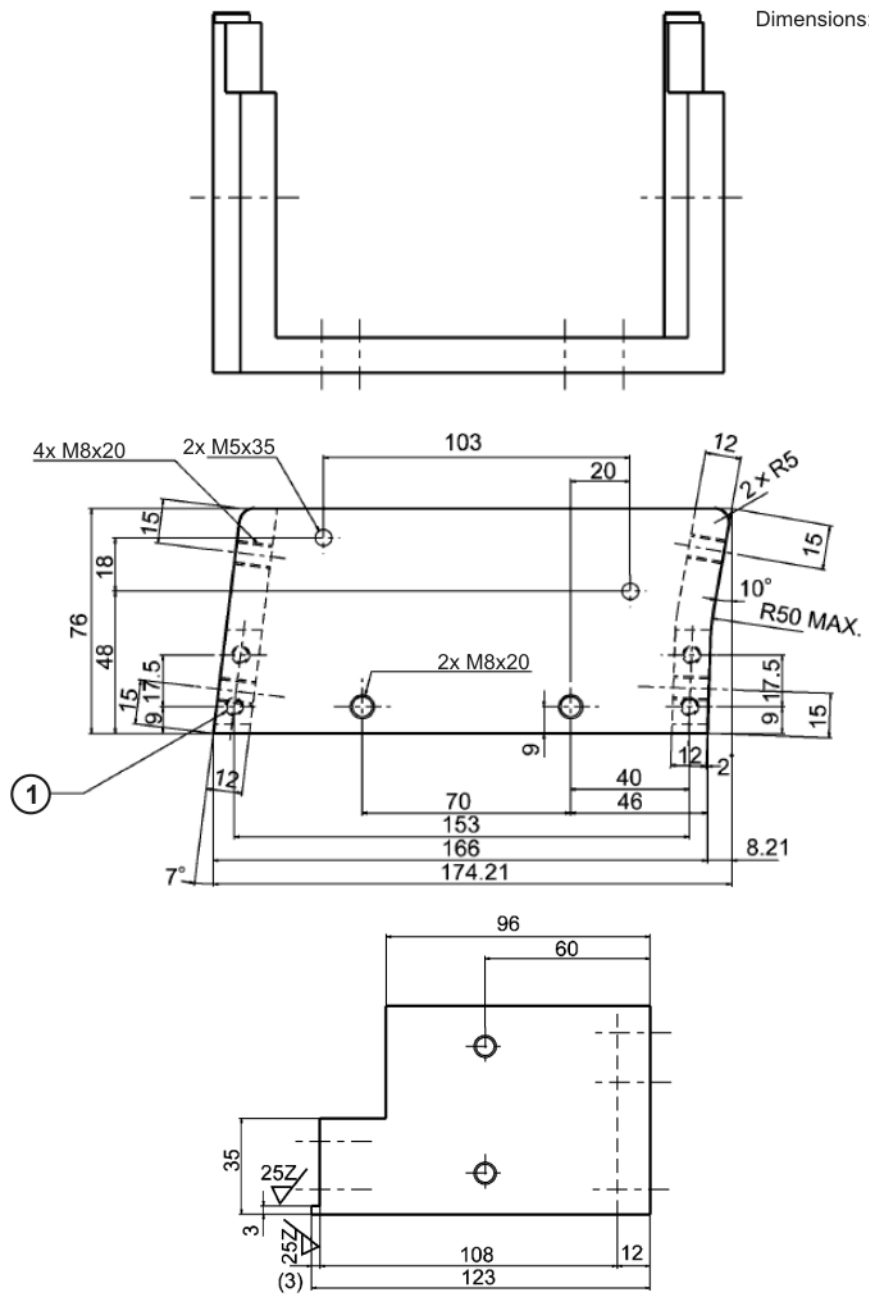

Fig. 6-8: Holder for stop, dimensioned drawing

6.4 KR 5 sixx R850: mechanical axis range limitation on axis 3, dimensioned drawings

Stop

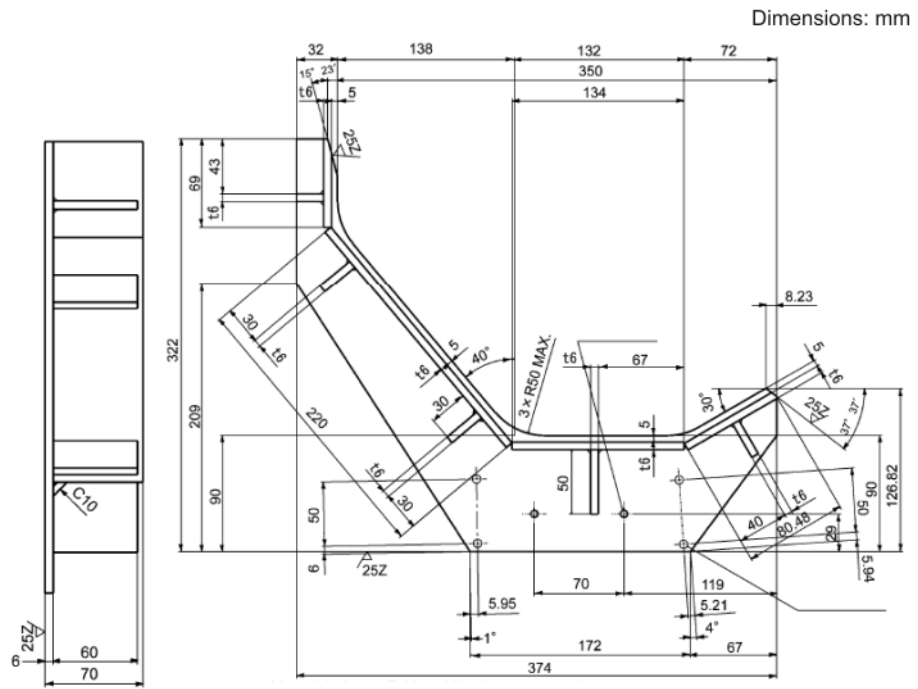

Fig. 6-9: Mechanical stop, dimensioned drawing

Spacer

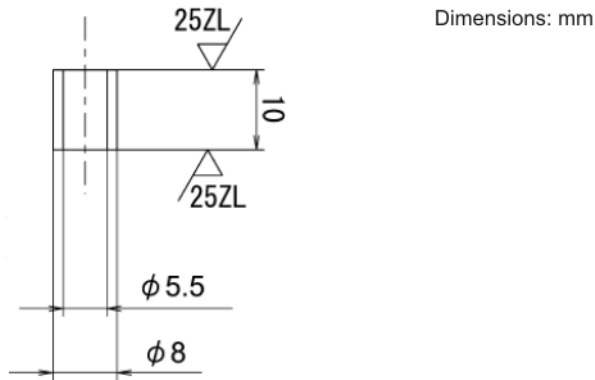

Fig. 6-10: Spacer, dimensioned drawing

Holder for stop

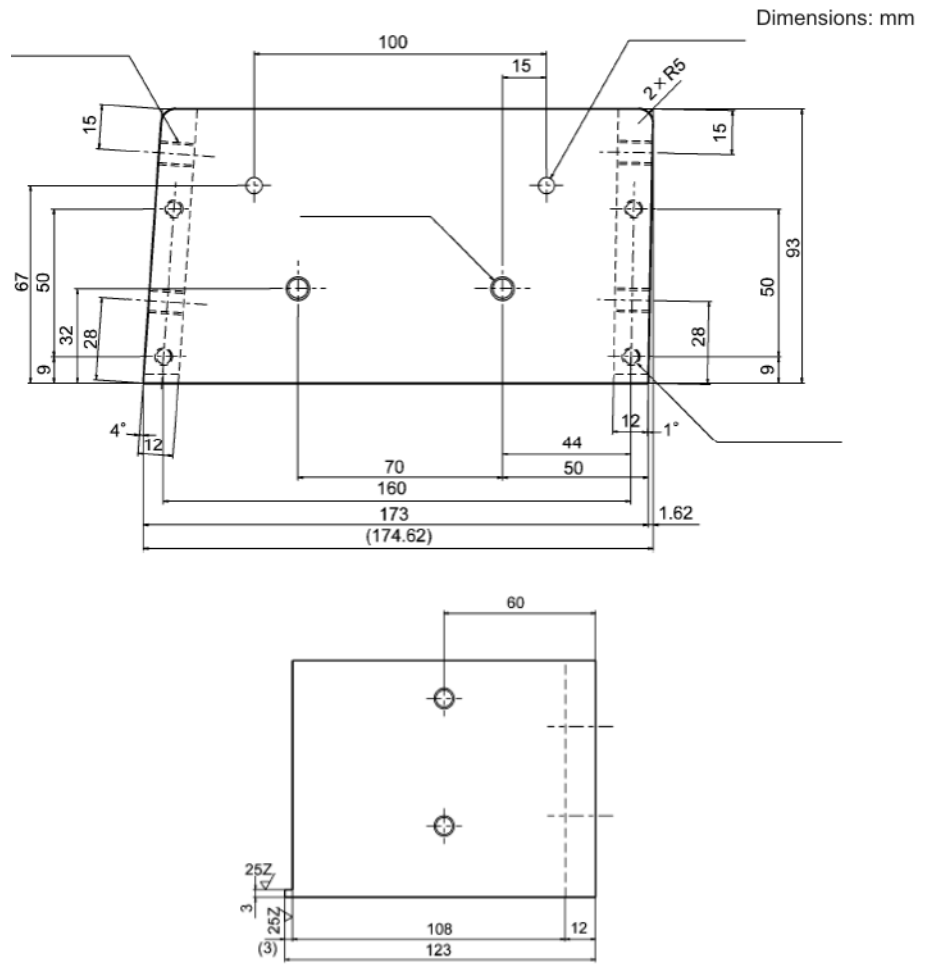

Fig. 6-11: Holder for stop, dimensioned drawing

7 KUKA Service

7.1 Requesting support

Introduction The KUKA Roboter GmbH documentation offers information on operation and provides assistance with troubleshooting. For further assistance, please contact your local KUKA subsidiary.

Information The following information is required for processing a support request:

- Model and serial number of the robot
- Model and serial number of the controller
- Model and serial number of the linear unit (if applicable)
- Version of the KUKA System Software
- Optional software or modifications
- Archive of the software
- Application used
- Any external axes used
- Description of the problem, duration and frequency of the fault

7.2 KUKA Customer Support

Availability KUKA Customer Support is available in many countries. Please do not hesitate to contact us if you have any questions.

Argentina Ruben Costantini S.A. (Agency)
Luis Angel Huergo 13 20
Parque Industrial
2400 San Francisco (CBA)
Argentina
Tel. +54 3564 421033
Fax +54 3564 428877
ventas@costantini-sa.com

Australien Headland Machinery Pty. Ltd.
Victoria (Head Office & Showroom)
95 Highbury Road
Burwood
Victoria 31 25
Australien
Tel. +61 3 9244-3500
Fax +61 3 9244-3501
vic@headland.com.au
www.headland.com.au

Belgium	KUKA Automatisering + Robots N.V. Centrum Zuid 1031 3530 Houthalen Belgium Tel. +32 11 516160 Fax +32 11 526794 info@kuka.be www.kuka.be
Brazil	KUKA Roboter do Brasil Ltda. Avenida Franz Liszt, 80 Parque Novo Mundo Jd. Guançã CEP 02151 900 São Paulo SP Brazil Tel. +55 11 69844900 Fax +55 11 62017883 info@kuka-roboter.com.br
Chile	Robotec S.A. (Agency) Santiago de Chile Chile Tel. +56 2 331-5951 Fax +56 2 331-5952 robotec@robotec.cl www.robotec.cl
China	KUKA Automation Equipment (Shanghai) Co., Ltd. Songjiang Industrial Zone No. 388 Minshen Road 201612 Shanghai China Tel. +86 21 6787-1808 Fax +86 21 6787-1805 info@kuka-sha.com.cn www.kuka.cn
Germany	KUKA Roboter GmbH Zugspitzstr. 140 86165 Augsburg Germany Tel. +49 821 797-4000 Fax +49 821 797-1616 info@kuka-roboter.de www.kuka-roboter.de

France	KUKA Automatismes + Robotique SAS Techvallée 6, Avenue du Parc 91140 Villebon S/Yvette France Tel. +33 1 6931660-0 Fax +33 1 6931660-1 commercial@kuka.fr www.kuka.fr
Indien	KUKA Robotics India Pvt. Ltd. Office Number-7, German Centre, Level 12, Building No. - 9B DLF Cyber City Phase III 122 002 Gurgaon Haryana Indien Tel. +91 124 4635774 Fax +91 124 4635773 info@kuka.in www.kuka.in
Italy	KUKA Roboter Italia S.p.A. Via Pavia 9/a - int.6 10098 Rivoli (TO) Italy Tel. +39 011 959-5013 Fax +39 011 959-5141 kuka@kuka.it www.kuka.it
Japan	KUKA Robotics Japan K.K. Daiba Garden City Building 1F 2-3-5 Daiba, Minato-ku Tokyo 135-0091 Japan Tel. +81 3 6380-7311 Fax +81 3 6380-7312 info@kuka.co.jp
Korea	KUKA Robotics Korea Co. Ltd. RIT Center 306, Gyeonggi Technopark 1271-11 Sa 3-dong, Sangnok-gu Ansan City, Gyeonggi Do 426-901 Korea Tel. +82 31 501-1451 Fax +82 31 501-1461 info@kukakorea.com

- Malaysia** KUKA Robot Automation Sdn Bhd
South East Asia Regional Office
No. 24, Jalan TPP 1/10
Taman Industri Puchong
47100 Puchong
Selangor
Malaysia
Tel. +60 3 8061-0613 or -0614
Fax +60 3 8061-7386
info@kuka.com.my
- Mexico** KUKA de Mexico S. de R.L. de C.V.
Rio San Joaquin #339, Local 5
Colonia Pensil Sur
C.P. 11490 Mexico D.F.
Mexico
Tel. +52 55 5203-8407
Fax +52 55 5203-8148
info@kuka.com.mx
- Norway** KUKA Sveiseanlegg + Roboter
Bryggeveien 9
2821 Gjøvik
Norway
Tel. +47 61 133422
Fax +47 61 186200
geir.ulsrud@kuka.no
- Austria** KUKA Roboter Austria GmbH
Vertriebsbüro Österreich
Regensburger Strasse 9/1
4020 Linz
Austria
Tel. +43 732 784752
Fax +43 732 793880
office@kuka-roboter.at
www.kuka-roboter.at
- Poland** KUKA Roboter Austria GmbH
Spółka z ograniczoną odpowiedzialnością
Oddział w Polsce
Ul. Porcelanowa 10
40-246 Katowice
Poland
Tel. +48 327 30 32 13 or -14
Fax +48 327 30 32 26
ServicePL@kuka-roboter.de

Portugal KUKA Sistemas de Automatización S.A.
Rua do Alto da Guerra n° 50
Armazém 04
2910 011 Setúbal
Portugal
Tel. +351 265 729780
Fax +351 265 729782
kuka@mail.telepac.pt

Russia OOO KUKA Robotics Rus
Webnaja ul. 8A
107143 Moskau
Russia
Tel. +7 495 781-31-20
Fax +7 495 781-31-19
kuka-robotics.ru

Sweden KUKA Svetsanläggningar + Robotar AB
A. Odhners gata 15
421 30 Västra Frölunda
Sweden
Tel. +46 31 7266-200
Fax +46 31 7266-201
info@kuka.se

Schweiz KUKA Roboter Schweiz AG
Industriestr. 9
5432 Neuenhof
Schweiz
Tel. +41 44 74490-90
Fax +41 44 74490-91
info@kuka-roboter.ch
www.kuka-roboter.ch

Spain KUKA Robots IBÉRICA, S.A.
Pol. Industrial
Torrent de la Pastera
Carrer del Bages s/n
08800 Vilanova i la Geltrú (Barcelona)
Spain
Tel. +34 93 8142-353
Fax +34 93 8142-950
Comercial@kuka-e.com
www.kuka-e.com

South Africa	Jendamark Automation LTD (Agency) 76a York Road North End 6000 Port Elizabeth South Africa Tel. +27 41 391 4700 Fax +27 41 373 3869 www.jendamark.co.za
Taiwan	KUKA Robot Automation Taiwan Co., Ltd. No. 249 Pujong Road Jungli City, Taoyuan County 320 Taiwan, R. O. C. Tel. +886 3 4331988 Fax +886 3 4331948 info@kuka.com.tw www.kuka.com.tw
Thailand	KUKA Robot Automation (M)SdnBhd Thailand Office c/o Maccall System Co. Ltd. 49/9-10 Soi Kingkaew 30 Kingkaew Road Tt. Rachatheva, A. Bangpli Samutprakarn 10540 Thailand Tel. +66 2 7502737 Fax +66 2 6612355 atika@ji-net.com www.kuka-roboter.de
Czech Republic	KUKA Roboter Austria GmbH Organisation Tschechien und Slowakei Sezemická 2757/2 193 00 Praha Horní Počernice Czech Republic Tel. +420 22 62 12 27 2 Fax +420 22 62 12 27 0 support@kuka.cz
Hungary	KUKA Robotics Hungaria Kft. Fő út 140 2335 Taksony Hungary Tel. +36 24 501609 Fax +36 24 477031 info@kuka-robotics.hu

USA KUKA Robotics Corp.
22500 Key Drive
Clinton Township
48036
Michigan
USA
Tel. +1 866 8735852
Fax +1 586 5692087
info@kukarobotics.com
www.kukarobotics.com

UK KUKA Automation + Robotics
Hereward Rise
Halesowen
B62 8AN
UK
Tel. +44 121 585-0800
Fax +44 121 585-0900
sales@kuka.co.uk

Index

Numbers

2004/108/EC 39
 2006/42/EC 39
 89/336/EEC 39
 95/16/EC 39

A

Accessories 5, 15, 21
 Additional data 15
 Ambient conditions 8
 Ambient temperature 7
 Appendix 51
 Applied norms and regulations 39
 Arm 6
 AUT 27
 AUT EXT 27
 Automatic 27
 Automatic External 27
 Automatic mode 37
 Axis data 8
 Axis range 23

B

Base frame 6
 Basic data 7
 Brake defect 32
 Braking distance 23

C

CE mark 22
 Cleaning work 37
 Connecting cables 5, 8, 21

D

Danger zone 23
 Declaration of conformity 22
 Declaration of incorporation 21, 22
 Decommissioning 38
 Description, robot 5
 Dimensions, transport 47
 Disposal 38

E

EC declaration of conformity 22
 EMC Directive 22, 39
 EMERGENCY STOP 26
 EMERGENCY STOP button 26, 28, 29, 35
 EMERGENCY STOP device 28, 29, 32
 EMERGENCY STOP, external 26, 27, 29, 35
 EMERGENCY STOP, local 26, 35
 EN 60204-1 40
 EN 61000-6-2 39
 EN 61000-6-4 40
 EN 614-1 39
 EN 954-1 39
 EN ISO 10218-1 39
 EN ISO 12100-1 39
 EN ISO 12100-2 39

EN ISO 13850 39
 Enabling device 27, 29, 32
 Enabling switches 29, 30
 ESC 26
 External axes 21, 23

F

Fastening threads 15
 Faults 33
 Firewall 35
 Fork lift truck 48
 Function test 34

G

General safety measures 32
 Guard interlock 28

H

Handling equipment 48
 Hazardous substances 38

I

In-line wrist 6
 Industrial robot 21
 Instructions for mechanical axis range limitation 41
 Instructions for mechanical axis range limitation, A1 42
 Instructions for mechanical axis range limitation, A2 43
 Intended use 21

J

Jog mode 30, 32

K

KCP 5, 23, 33
 Keyboard, external 33
 KR 5 sixx R650 instructions for mechanical axis range limitation, A3 44
 KR 5 sixx R650 mechanical axis range limitation, axis 3, dimensioned drawings 53
 KR 5 sixx R850 instructions for mechanical axis range limitation, A3 45
 KR 5 sixx R850 mechanical axis range limitation, axis 3, dimensioned drawings 55
 KUKA Customer Support 57

L

Labeling 31
 Labels 18
 Liability 21
 Lifting tackle 48
 Linear unit 21
 Link arm 6
 Loads acting on the foundation 14
 Low Voltage Directive 22

M

Machine data 35
Machinery Directive 22, 39
Maintenance 37
Manipulator 5, 21, 23, 25
Manual High Velocity 27
Manual mode 36
Manual Reduced Velocity 27
Mechanical axis range limitation, axis 1, dimensioned drawings 51
Mechanical axis range limitation, axis 2, dimensioned drawings 52
Mode selector switch 27
Mounting flange 13
Mouse, external 33

N

Network security 35

O

Operating modes 27
Operator 23, 24
Operator safety 26, 28, 32
Options 5, 21
Overload 32
Overview of the robot system 5

P

Panic position 30
Payload diagram 12
Payloads 12
Personnel 23
Plant integrator 23
Plates and labels 18
Positioner 21
Preventive maintenance work 37
Principal components 5
Product description 5
Protective equipment 30

Q

Qualifying inputs 27, 35

R

Reaction distance 23
Recommissioning 34
Repair 37
Robot controller 5, 21, 35
Robot system 5
Rotating column 6

S

Safeguards, external 31
Safety 21
Safety functions 32
Safety logic 26
Safety zone 23, 25
Safety, general 21
Service, KUKA Roboter 57
Simulation 36
Single point of control 38

Software 5, 21
Software limit switches 31, 32
Start-up 34
STOP 0 23, 26
STOP 1 23, 26
STOP 2 23, 26
Stop category 0 23
Stop category 1 23
Stop category 2 23
Stop reactions 25
Stopping distance 23, 25
Storage 38
Supplementary load 13
Support request 57
System integrator 22, 23, 24

T

T1 23, 27
T2 23, 27
Teach pendant 5, 21
Technical data 7
Terms used, safety 23
Transport dimensions 47
Transport position 33, 34, 47
Transportation 33, 47
Turn-tilt table 21

U

Use, contrary to intended use 21
Use, improper 21
User 23

V

Valve assembly 16
Valve group 6
Vibration stress 7
Virus protection 35

W

Working envelope 9
Workspace 23, 25
Wrist I/O cable 6

